



Aluk 2.5[®]

ALUK 2.5

Grande como as suas ideias.

de ideias.

A gente acredita que o poder das suas ideias é muito maior do que você imagina. É por isso que somos os únicos a atender 3 segmentos diferentes, ampliando assim as possibilidades de fazer parte dos seus projetos.



Componentes



Perfis



Persianas



PERSPECTIVA
(sem escala)

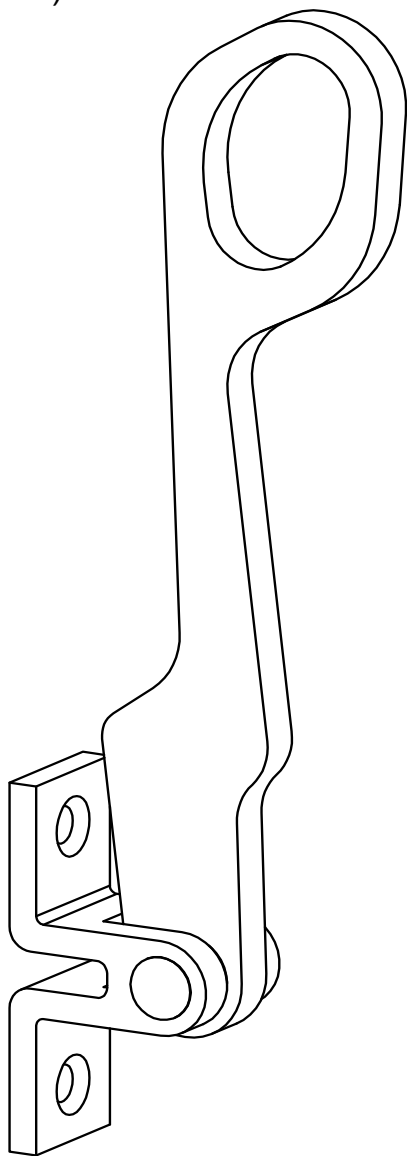

DIMENSÕES
(escala 1:2)

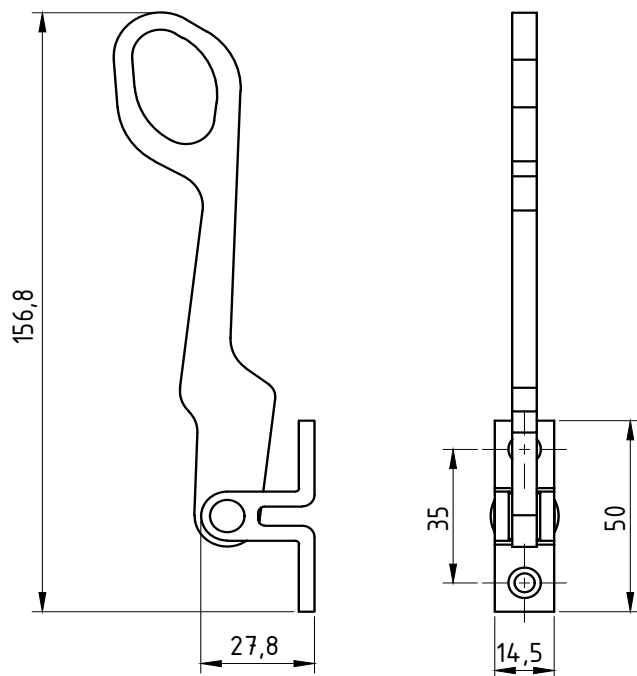

CARACTERÍSTICAS:

Componentes:	Matéria-prima:
Base	Alumínio
Eixo	Latão
Alça	Alumínio
Buchas	Poliamida

Acabamento Anodizado e Pintado

Preto	Fosco	Branco
-------	-------	--------

Embalagem

10 Alavancas

CÓDIGO	ACABAMENTO
ALA-055	Fosco
ALA-057	Preto
ALA-057EB	Branco

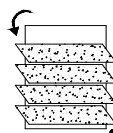

JANELA
BASCULANTE

PERSPECTIVA:
(sem escala)

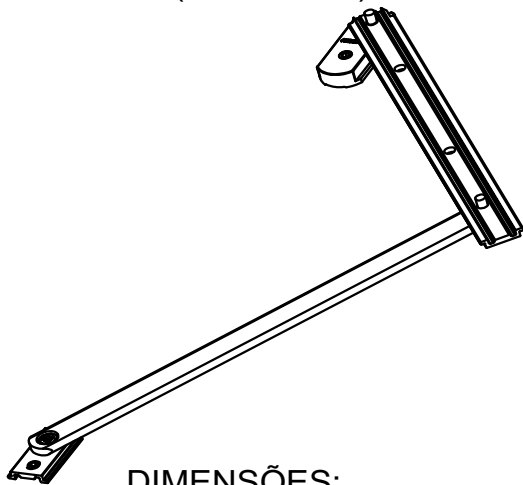

DIMENSÕES:
(escala 1:1)

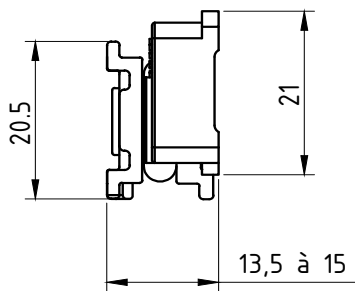

Regulagem do
freio

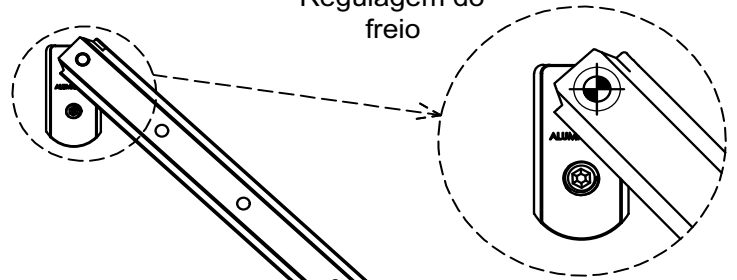

Abertura de 90°
(para limpeza e
regulagem do freio)

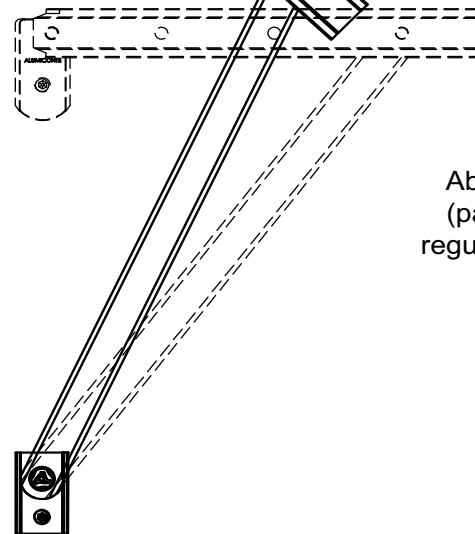

CARACTERÍSTICAS:

Componentes:	Matéria-prima:
Estrutura	Alumínio
Rebites	Alumínio
Guia deslizante	Poliamida
Buchas	Poliamida
Parafusos	Aço inox

Acabamento Anodizado e Pintado

Preto Fosco Branco

Embalagem

1 par de braços
Parafusos Inox

DETALHE DE APLICAÇÃO: (Sem escala)

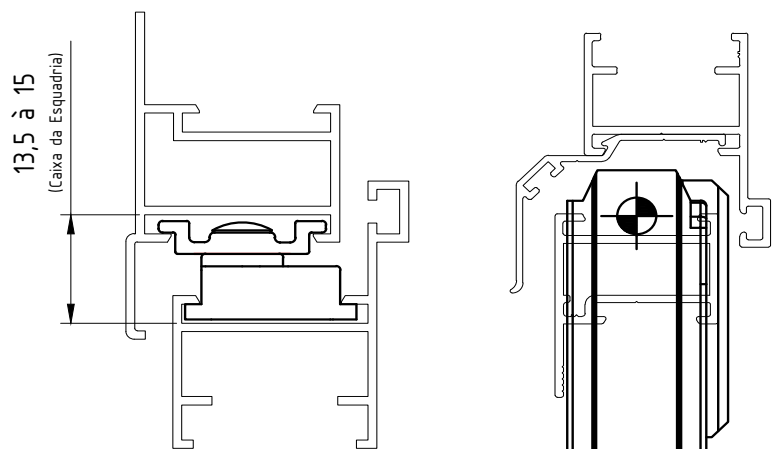

13,5 à 15
(Caixa da Esquadria)

Código Preto	Código Fosco	Código Branco	Comp. (mm)	Altura (mm) Min./Máx.	Largura Máxima (mm)	Peso (Kg) Admissível	Vidro (mm) Esp. Máxima
BRA-706	BRA-7060	BRA-706EB	200	210 a 270	800	4,0	4
BRA-705	BRA-7050	BRA-705EB	250	270 a 400	800	5,0	4
BRA-704	BRA-7040	BRA-704EB	400	450 a 650	800	7,0	4
BRA-702	BRA-7020	BRA-702EB	500	550 a 1000	800	10,5	4
BRA-703	BRA-7030	BRA-703EB	750	770 a 1000	800	12,0	4
BRA-725	BRA-7250	BRA-725EB	810	850 a 1000	1000	13,0	4

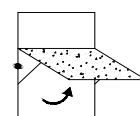

JANELAS
MAXIM-AR

DIMENSÕES:
(escala 1,5:1)

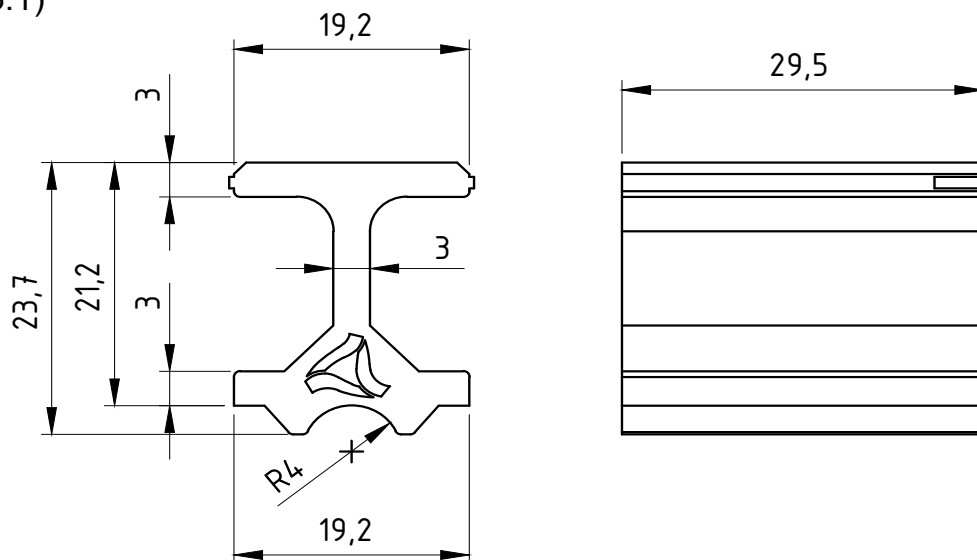

PERSPECTIVA:
(escala 1,5:1)

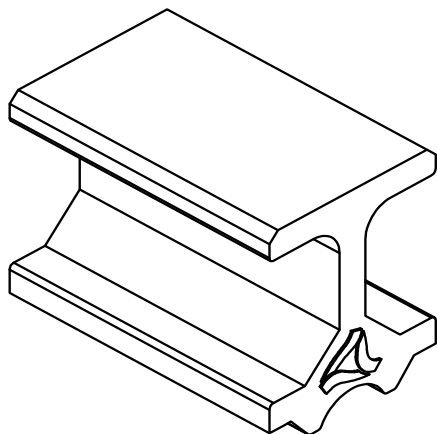

DETALHE DE APLICAÇÃO:
(sem escala)

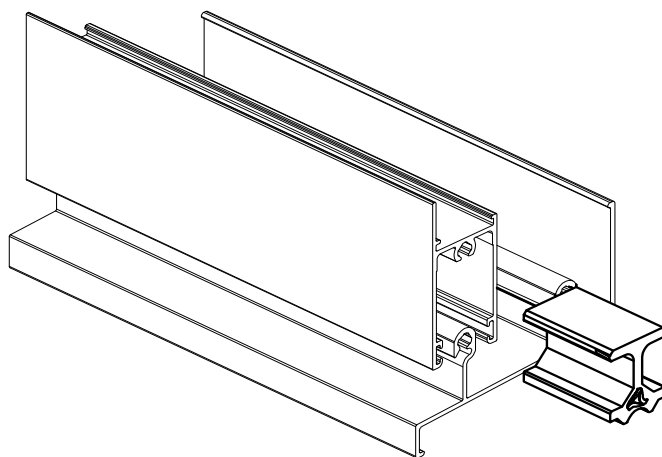

CARACTERÍSTICAS:

Componentes:	Matéria-prima:
Estrutura	Poliamida

Acabamento	Preto
------------	-------

Embalagem	100 Peças
-----------	-----------

CÓDIGO	ACABAMENTO
CAL 948	Preto

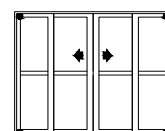

JANELAS
E PORTAS
DE CORRER

PERSPECTIVA:
(Escala 1:1)

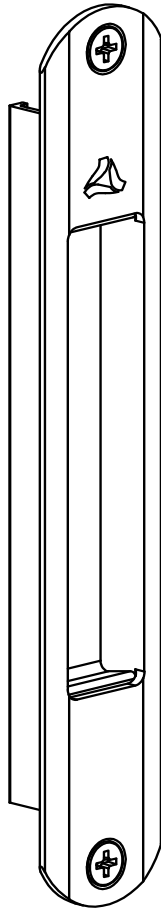

DIMENSÕES:
(escala 1:2)

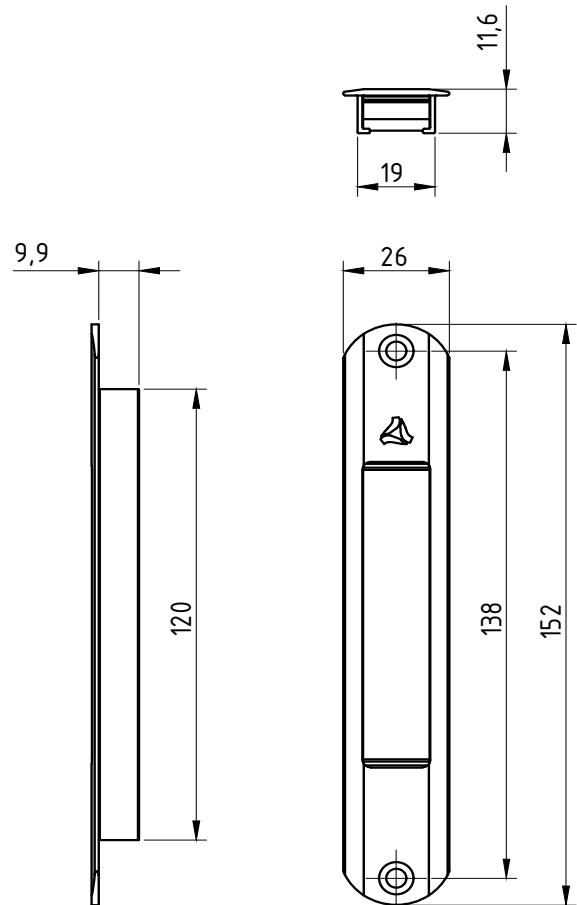

CARACTERÍSTICAS:

Componentes:	Matéria-prima:
Estrutura	Alumínio
Parafusos	Aço Inox

Acabamento Anodizado e Pintado		
Preto	Fosco	Branco

Embalagem	20 Conchas Cegas
	40 Parafusos

CÓDIGO	ACABAMENTO
CON-276	Fosco
CON-277	Preto
CON-277EB	Branco



JANELAS
E PORTAS
DE CORRER

PERSPECTIVA:
(sem escala)

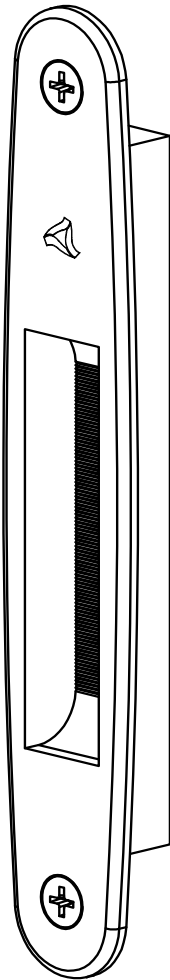

DIMENSÕES:
(escala 1:2)

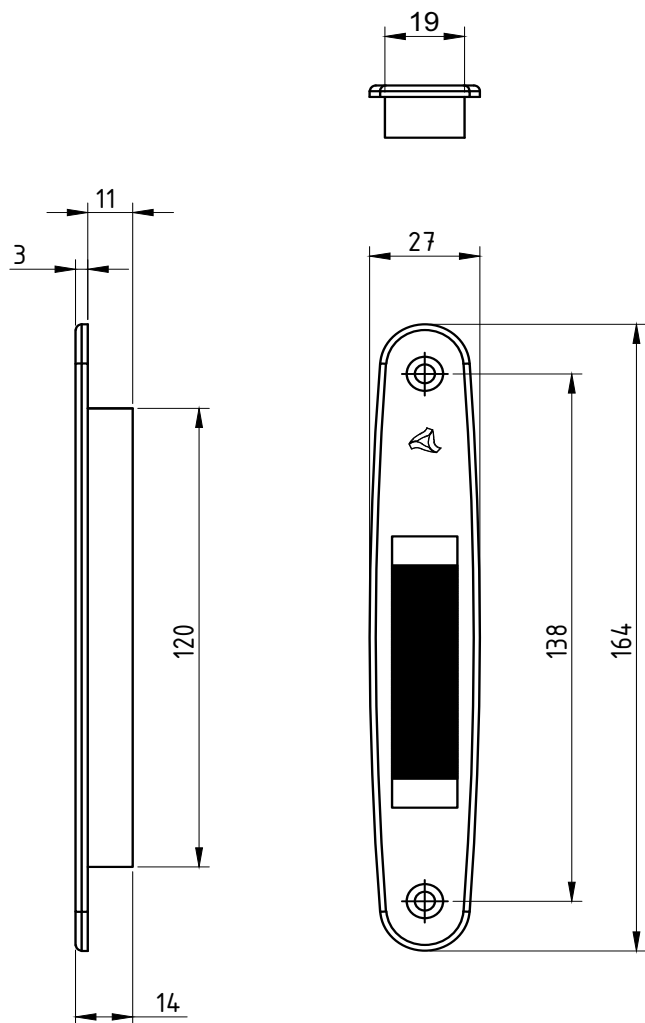

CARACTERÍSTICAS:

Componentes:	Matéria-prima:
Estrutura	Poliamida
Parafusos	Aço Inox

Acabamento	Preto	Branco
------------	-------	--------

Embalagem	20 Conchas cegas
	40 Parafusos

CÓDIGO	ACABAMENTO
CON-275	Preto
CON-275NB	Branco

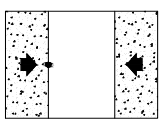

JANELAS
E PORTAS
DE CORRER

DIMENSÕES:
(escala 1:2)

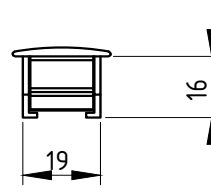

USINAGEM:
(escala 1:2)

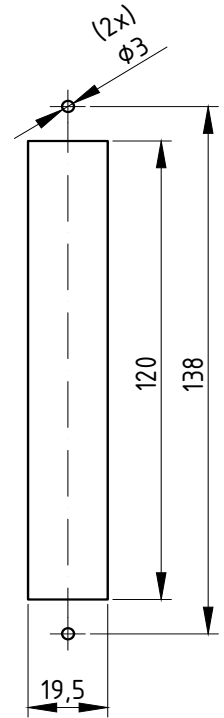

PERSPECTIVA:
(sem escala)

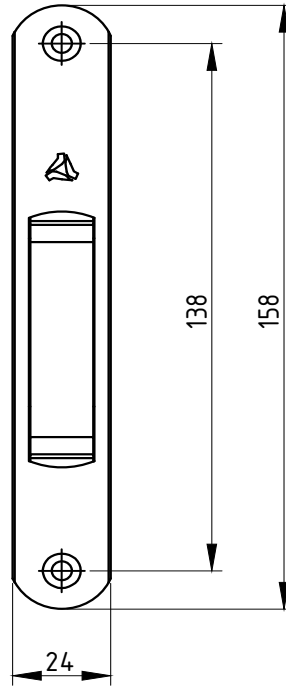
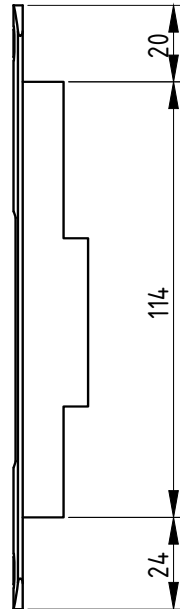
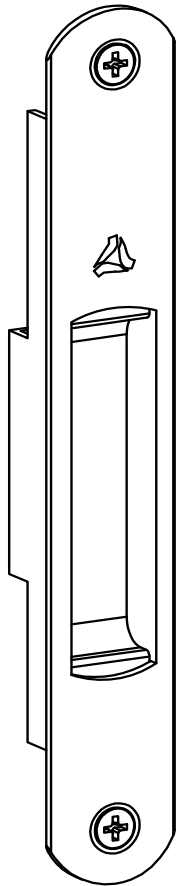

DETALHE DE MONTAGEM
(Sem Escala)

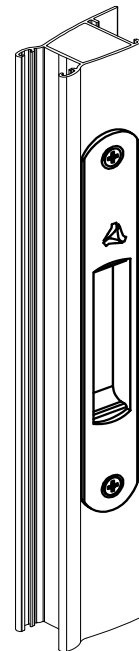

CARACTERÍSTICAS:

Componentes:	Matéria-prima:
Estrutura	Alumínio
Parafusos	Aço Inox

Acabamento Anodizado e Pintado		
Preto	Fosco	Branco

Embalagem	20 Conchas Cegas
	40 Parafusos

CÓDIGO	ACABAMENTO
CON-448	Preto
CON-4480	Fosco
CON-448EB	Branco



**JANELAS
E PORTAS
DE CORRER**

Julho/2008

PERSPECTIVA:
(sem escala)

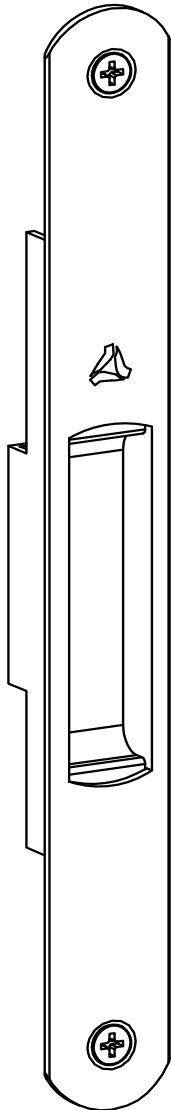

DIMENSÕES:
(escala 1:2)

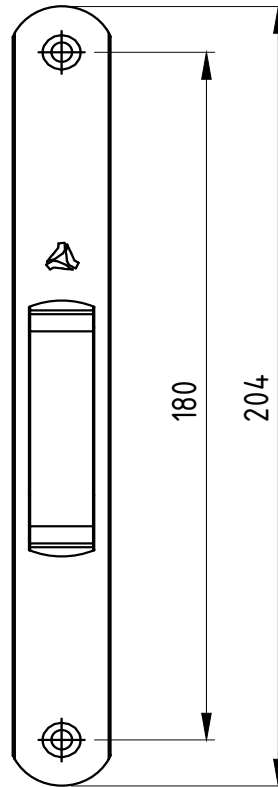
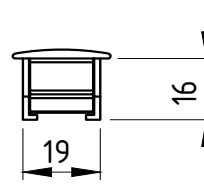
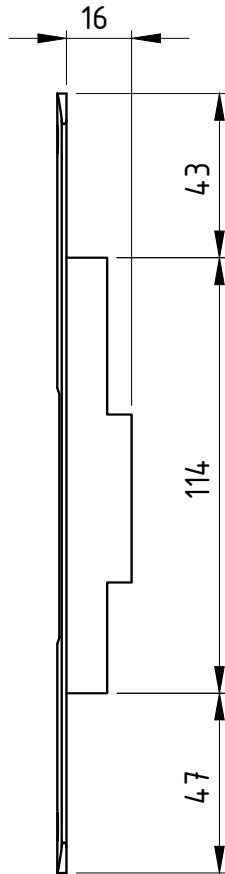

USINAGEM:
(escala 1:2)

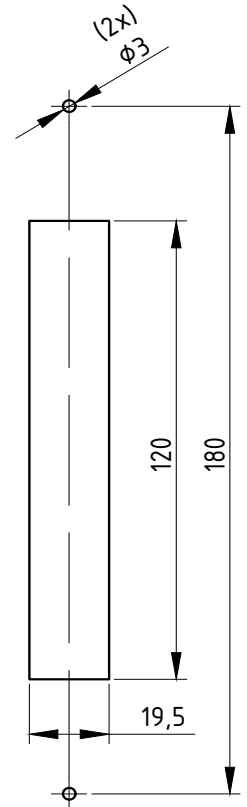

DETALHE DE MONTAGEM
(Sem Escala)

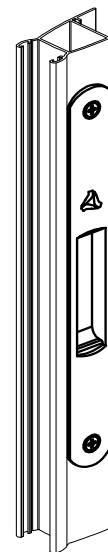

CARACTERÍSTICAS:

Componentes:	Matéria-prima:
Estrutura	Alumínio
Parafusos	Aço Inox

Acabamento Anodizado e Pintado		
Preto	Fosco	Branco

Embalagem	20 Conchas Cegas
	40 Parafusos

CÓDIGO	ACABAMENTO
CON-449	Preto
CON-4490	Fosco
CON-449EB	Branco



JANELAS
E PORTAS
DE CORRER

PERSPECTIVA:
(sem escala)

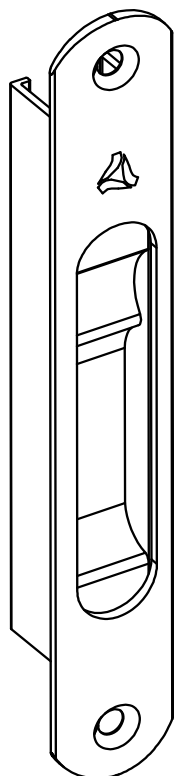

(escala 1:2)

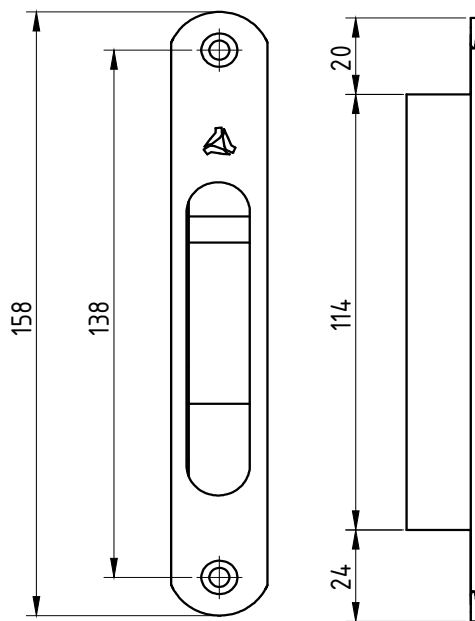
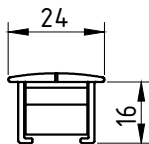

USINAGEM:
(escala 1:2)

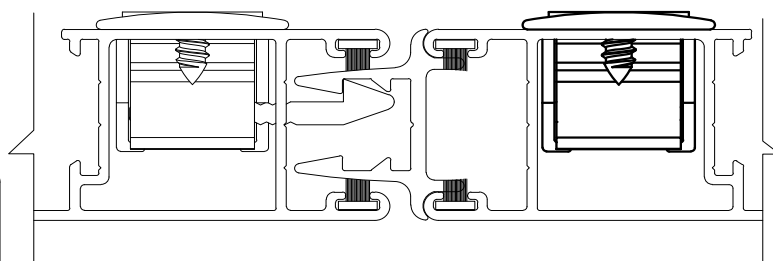
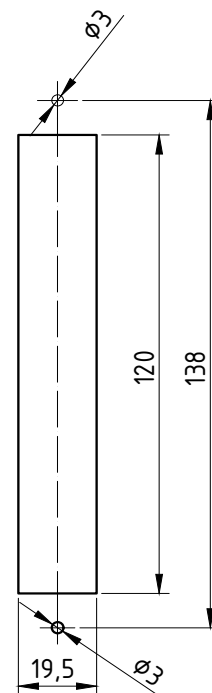

(escala 1:1)

Componentes:

Matéria-prima:

Estrutura

Alumínio

Parafusos

Aço Inox

Acabamento Anodizado e Pintado

Preto

Fosco

Branco

Bronze

Embalagem

20 Conchas Cegas

40 Parafusos

CÓDIGO

ACABAMENTO

CON-150

Preto

CON-1500

Fosco

CON-150EB

Branco

CON-150BR

Bronze

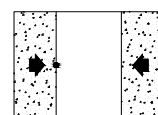

JANELAS
E PORTAS
DE CORRER

PERSPECTIVA:
(sem escala)

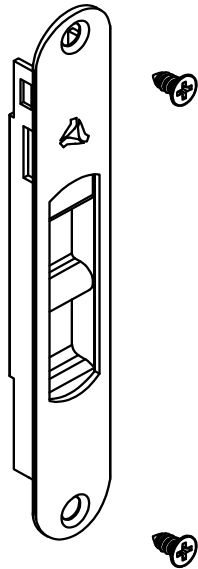

DIMENSÕES:
(escala 1:2)

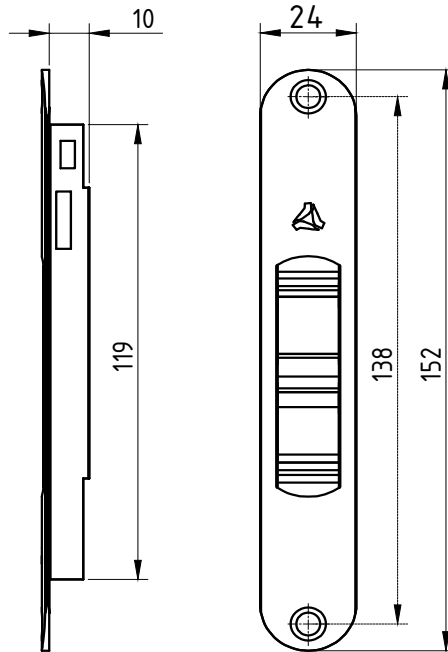

USINAGEM:
(escala 1:2)

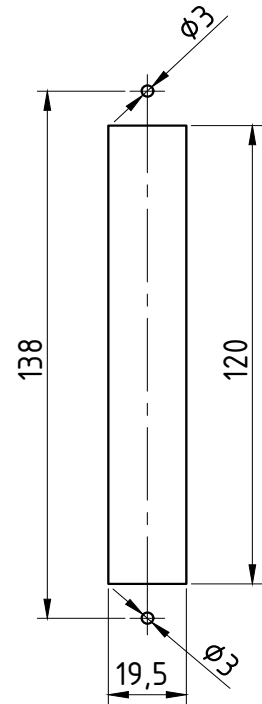

DETALHE DE APLICAÇÃO:
(sem escala)

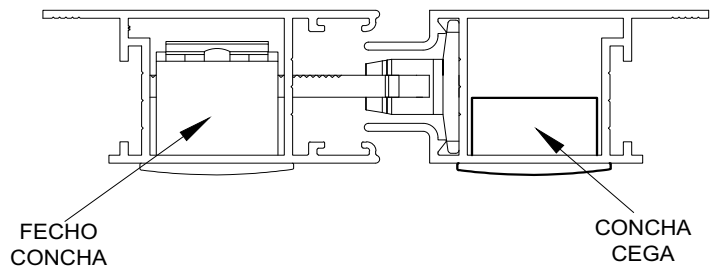

CARACTERÍSTICAS:

Componentes:	Matéria-prima:
Estrutura	Alumínio
Parafusos	Aço Inox

Acabamento Anodizado e Pintado		
Preto	Fosco	Branco

Embalagem	20 Conchas cegas
	40 Parafusos

CÓDIGO	ACABAMENTO
CON-200	Preto
CON-2000	Fosco
CON-200EB	Branco

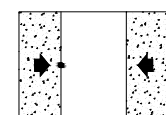

JANELAS
E PORTAS
DE CORRER

PERSPECTIVA:
(sem escala)

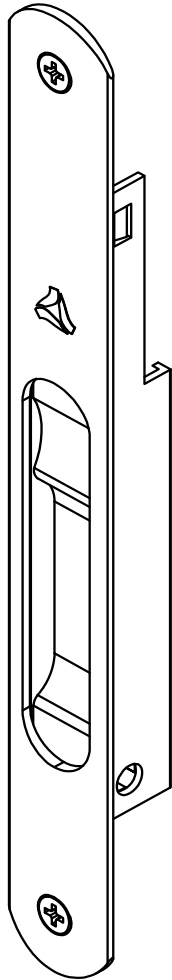

USINAGEM:
(escala 1:2)

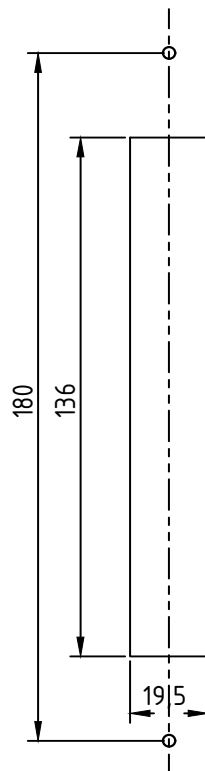

(escala 1:2)

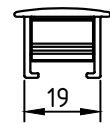
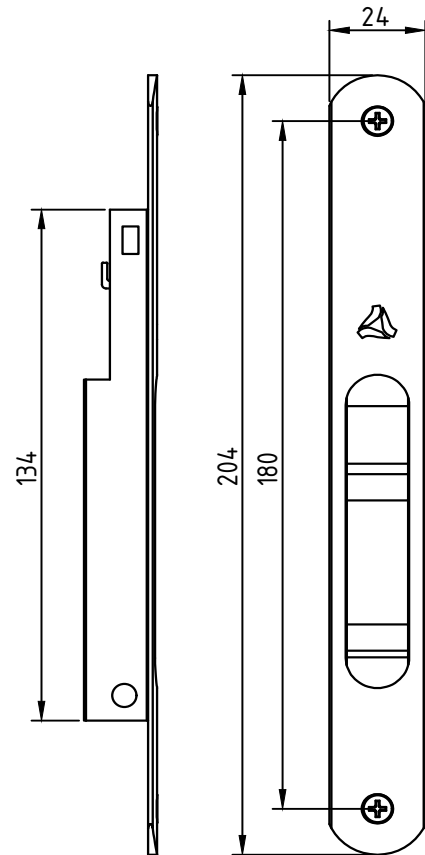

Componentes:

Matéria-prima:

Estrutura

Alumínio

Eixo de centro

Alumínio

Parafusos

Aço Inox

Acabamento Anodizado e Pintado

Preto

Fosco

Branco

Bronze

Embalagem

20 Conchas cegas

40 Parafusos

CÓDIGO

ACABAMENTO

CON-0155PT

Preto

CON-0155FS

Fosco

CON-0155BC

Branco

CON-0155BR

Bronze

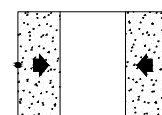

JANELAS
E PORTAS
DE CORRER

PERSPECTIVA:
(sem escala)

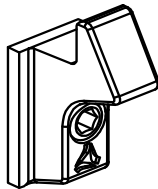

DIMENSÕES:
(escala 1:1)

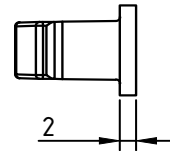
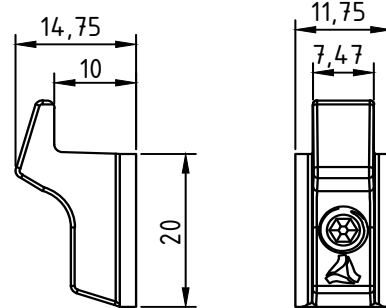

Utiliza 01 parafuso de Aço Inox
Allen sem cabeça M6 x 8

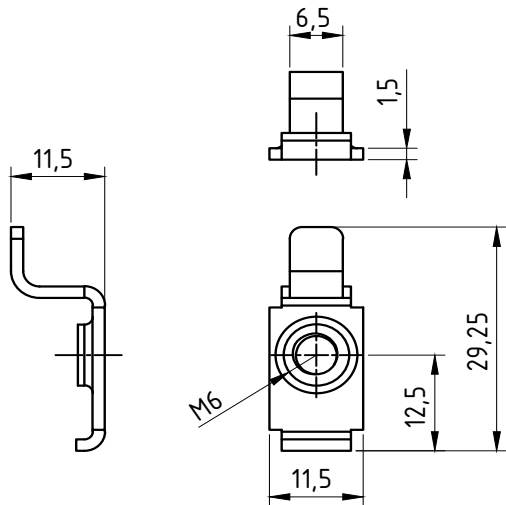

PERSPECTIVA:
(sem escala)

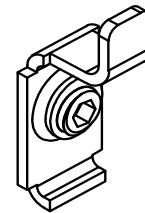

APLICAÇÃO:
(sem escala)

Utiliza 01 parafuso de Aço Inox
Allen sem cabeça M6 x 6

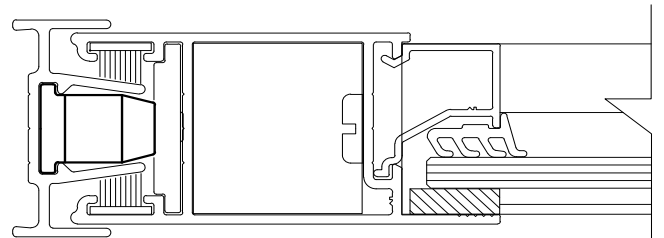

CARACTERÍSTICAS:

Componentes:	Matéria-prima:
Estrutura CON370/CON370EB	Zamac
Estrutura CON370NP/CON370NB	Poliamida 6 - 30% FV
Estrutura CON371	Aço Inox
Parafusos	Aço Inox

Acabamento	Preto	Branco	Natural
------------	-------	--------	---------

Embalagem	100 contrafechos
	100 parafusos

CÓDIGO	ACABAMENTO
CON-370	Preto
CON-370EB	Branco
CON-370NP	Preto
CON-370NB	Branco
CON-371	Natural

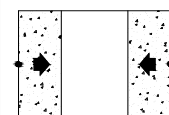

JANELAS
E PORTAS
DE CORRER

DIMENSÕES:
(escala 1:1)

PERSPECTIVA:
(sem escala)

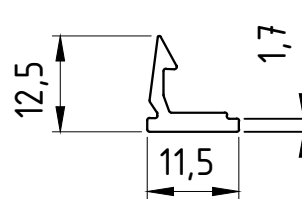
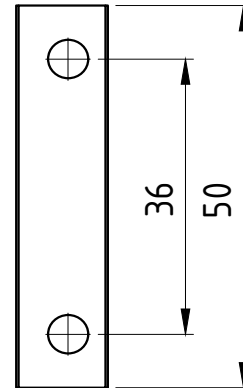
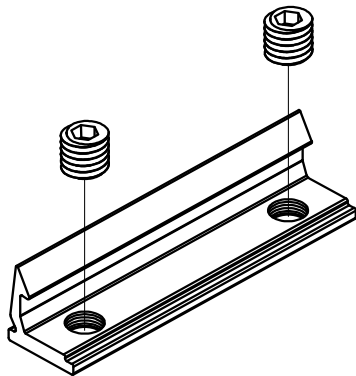

**ATENÇÃO: USO EXCLUSIVO
PARA O FEC-250**

CARACTERÍSTICAS:

Componentes:	Matéria-prima:
Estrutura	Alumínio
Parafusos	Aço Inox

Acabamento Anodizado e Pintado		
Preto	Fosco	Branco

Embalagem	20 Contra testas
	40 Parafusos

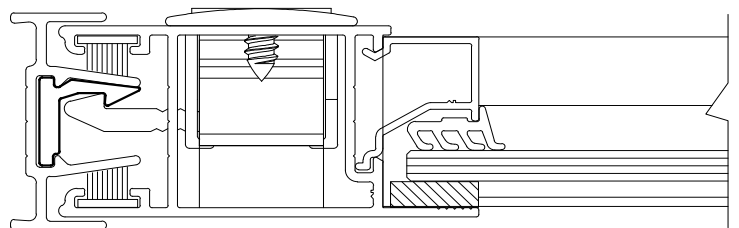

CÓDIGO	ACABAMENTO
CON-250	Preto
CON-2500	Fosco
CON-250EB	Branco



**JANELAS
E PORTAS
DE CORRER**

DIMENSÕES:
(escala 1:1)

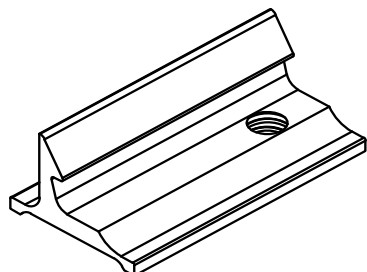

PERSPECTIVA:
(escala 1:1)

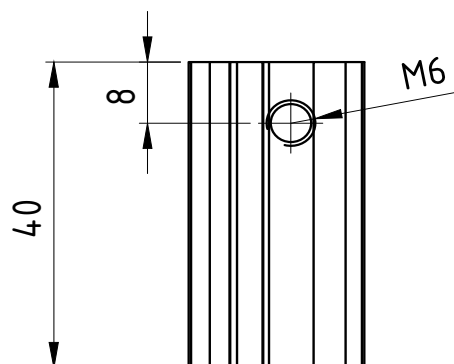
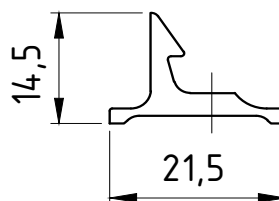
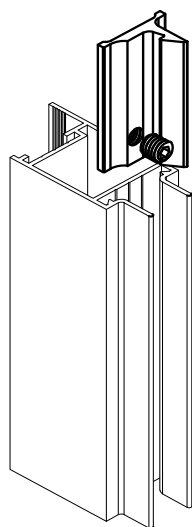

DETALHE DE APLICAÇÃO:
(sem escala)

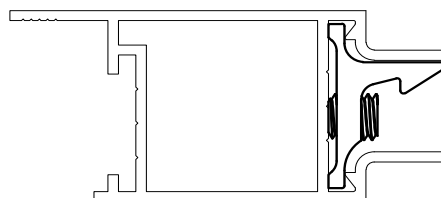

CARACTERÍSTICAS:

Componentes:	Matéria-prima:
Estrutura	Alumínio
Parafuso	Aço Inox

Acabamento
Fosco

Embalagem

20 Contrafechos
20 Parafusos

CÓDIGO	ACABAMENTO
CON-0251FS	Fosco
CON-0251PT	Preto
CON-0251BC	Branco

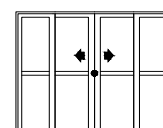

JANELAS
E PORTAS
DE CORRER



CONTRA TESTA

APLICAÇÃO:

ALUK 2.5®

Julho/2012

DIMENSÕES:
(escala 1:2)

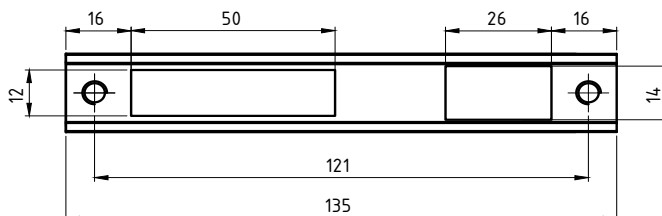
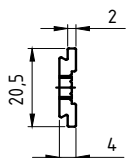

PERSPECTIVA:
(sem escala)



DETALHE DE APLICAÇÃO:
(Sem escala)

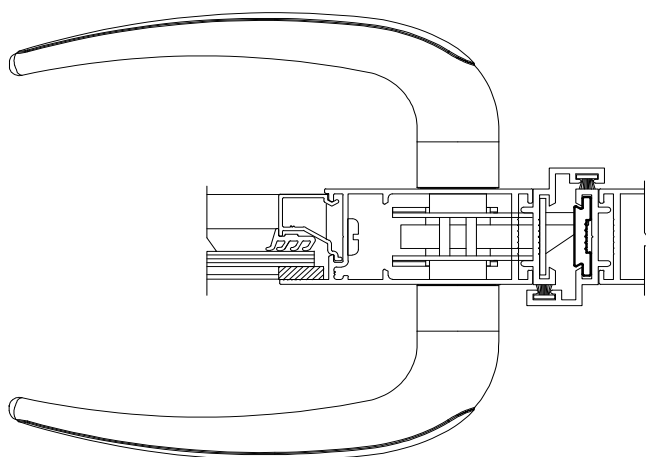

CARACTERÍSTICAS:

Componentes:	Matéria-prima:
Estrutura	Alumínio
Parafuso	Aço inox

Acabamentos		
Preto	Branco	Fosco

Embalagem	01 Contra testa
	02 Parafusos

CÓDIGO	ACABAMENTO
CON-295	Preto
CON-295EB	Branco
CON-295FS	Fosco

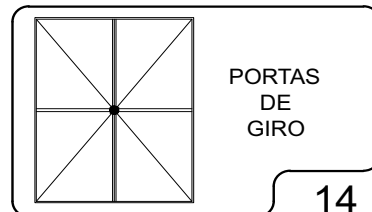

DIMENSÕES:
(escala 1:1)

PERSPECTIVA:
(escala 1,5:1)

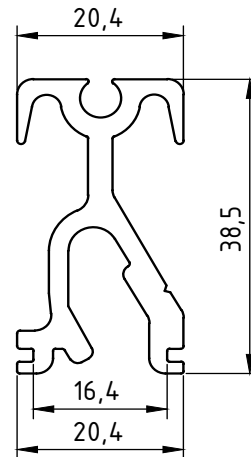
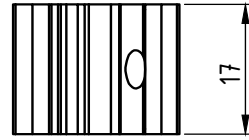
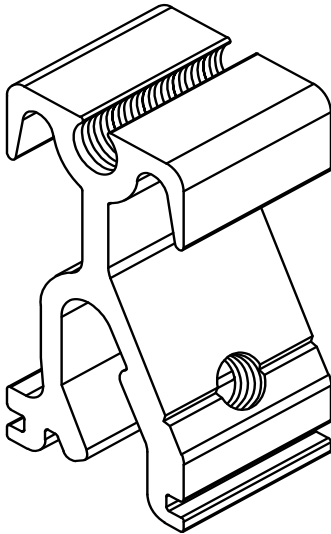

DETALHE DE APLICAÇÃO:
(sem escala)

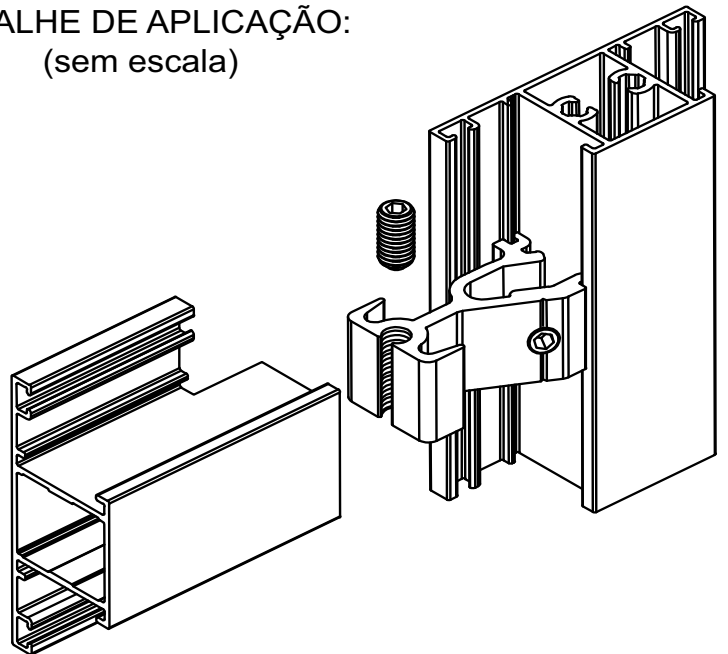

CARACTERÍSTICAS:

Componentes:	Matéria-prima:
Estrutura	Alumínio
Parafusos	Aço Inox

Acabamento	Natural
------------	---------

Embalagem	50 Fixadores
	100 Parafusos

CÓDIGO	ACABAMENTO
CON- 376	Natural

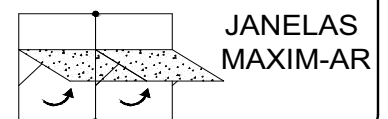

Janeiro/2005

DIMENSÕES:
(escala 1:2)

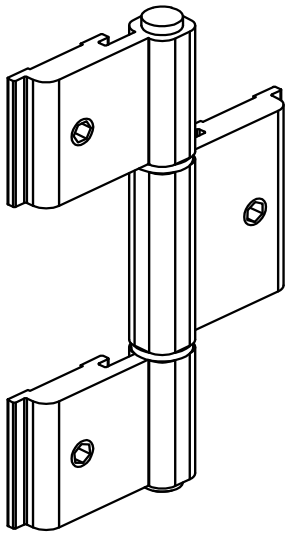

DOBRADIÇA SEM PUXADOR
(sem escala)

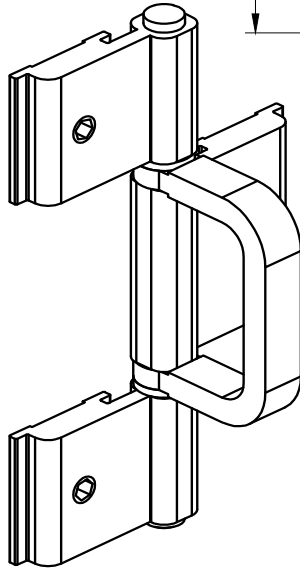

DOBRADIÇA COM PUXADOR
(sem escala)

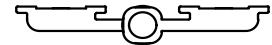
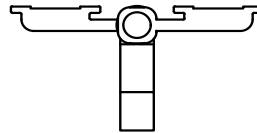
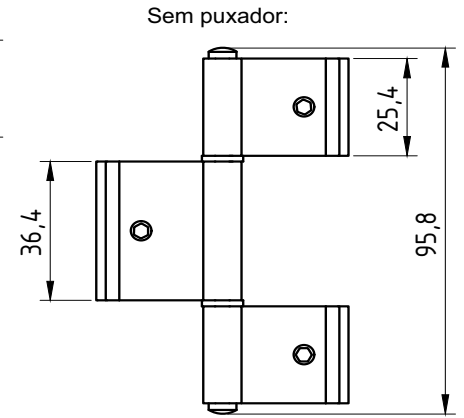
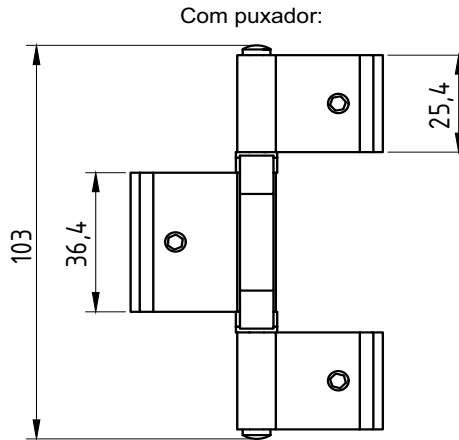

DETALHE DE APLICAÇÃO DA DOBRADIÇA SEM PUXADOR:
(escala 1:1)

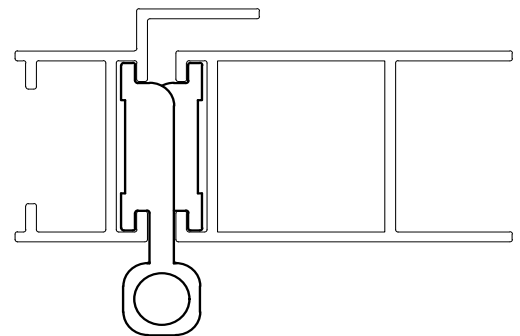

DETALHE DE APLICAÇÃO DA DOBRADIÇA COM PUXADOR:
(escala 1:1)

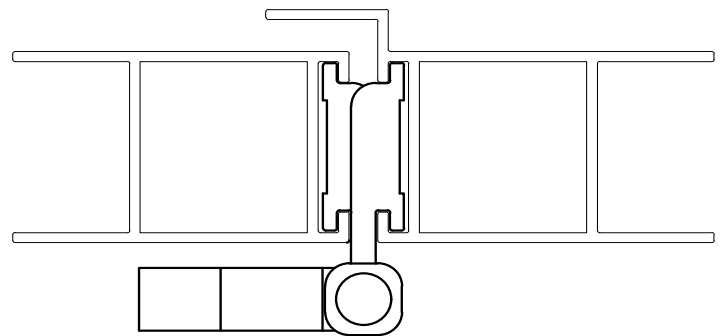

OBSERVAÇÃO:

Duas dobradiças por folha
Carga máxima 30 kg
Dimensões máximas 500 x 1400 mm

CARACTERÍSTICAS:

Componentes:	Matéria-prima:
Abas	Alumínio
Eixo central	Aço Inox
Buchas e cabo	Poliamida
Parafusos	Aço Inox

Acabamento Anodizado e Pintado		
Preto	Fosco	Branco

Embalagem	20 Dobradiças
	60 Parafusos

DESCRIÇÃO	CÓDIGO	ACAB.
Dobradiça sem puxador	DOB-8370	Fosco
	DOB-837	Preto
	DOB-837EB	Branco
Dobradiça com puxador	DOB-8380	Fosco
	DOB-838	Preto
	DOB-838EB	Branco

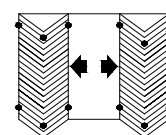

JANELAS E PORTAS CAMARÃO

PERSPECTIVA
(sem escala)

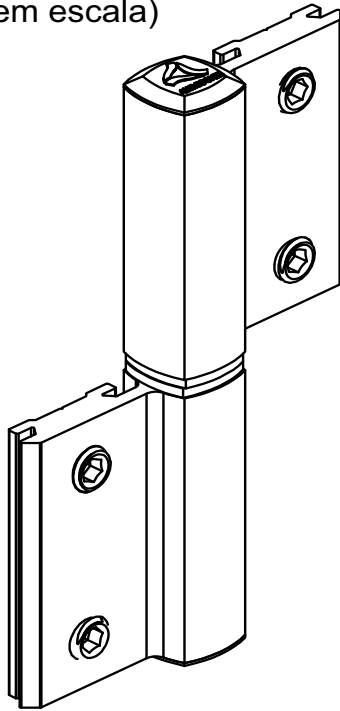

DIMENSÕES:
(escala 1:2)

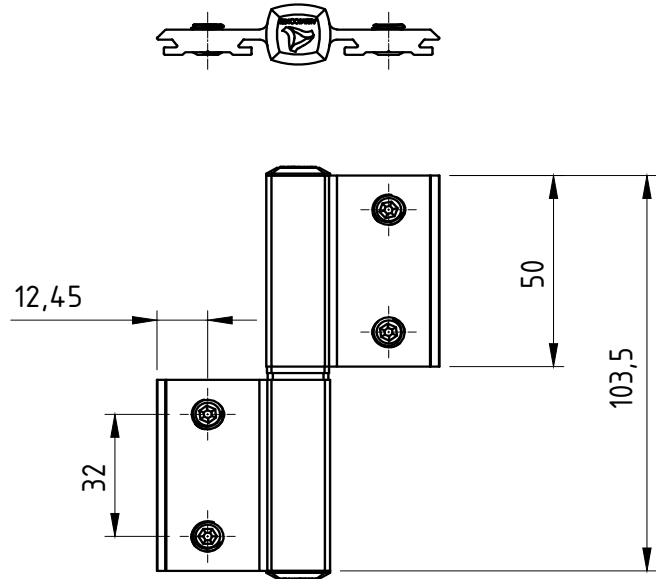

DETALHE DE APLICAÇÃO:
(escala 1:2)

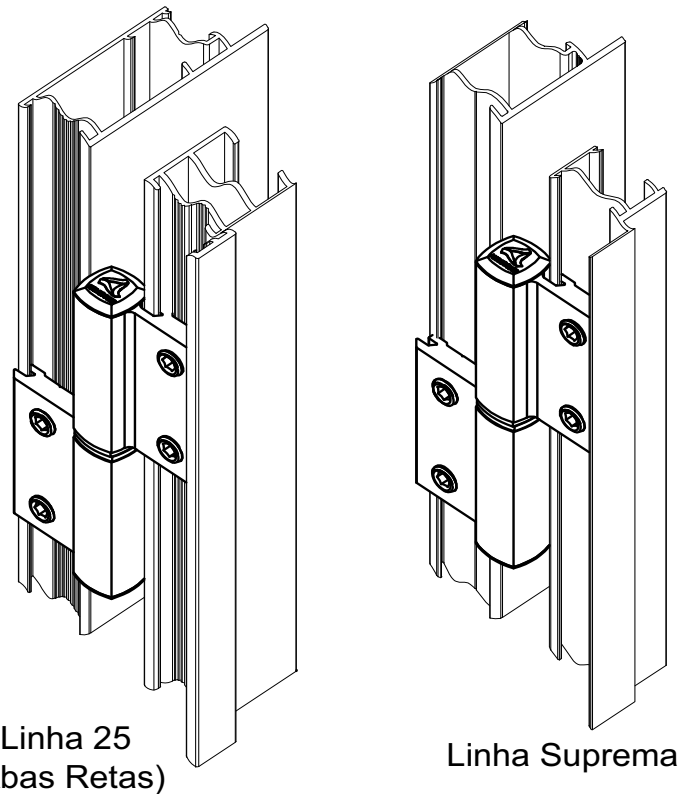

OBSERVAÇÃO:
Três dobradiças por folha
Carga máxima 25 kg
Dimensões máximas 900 x 2100 mm

CARACTERÍSTICAS:

Componentes:	Matéria-prima:
Abas	Alumínio
Eixo central	Alumínio
Buchas	Poliamida
Parafusos	Aço Inox

Acabamento Anodizado e Pintado		
Preto	Fosco	Branco

Embalagem	20 Dobradiças
	80 Parafusos

CÓDIGO	ACABAMENTO
DOB-840	Preto
DOB-841	Fosco
DOB-840EB	Branco

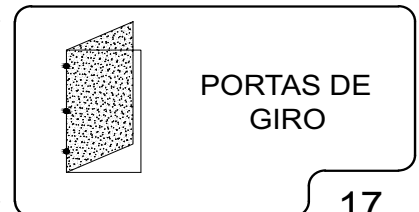

PERSPECTIVA:
(escala 1:1)

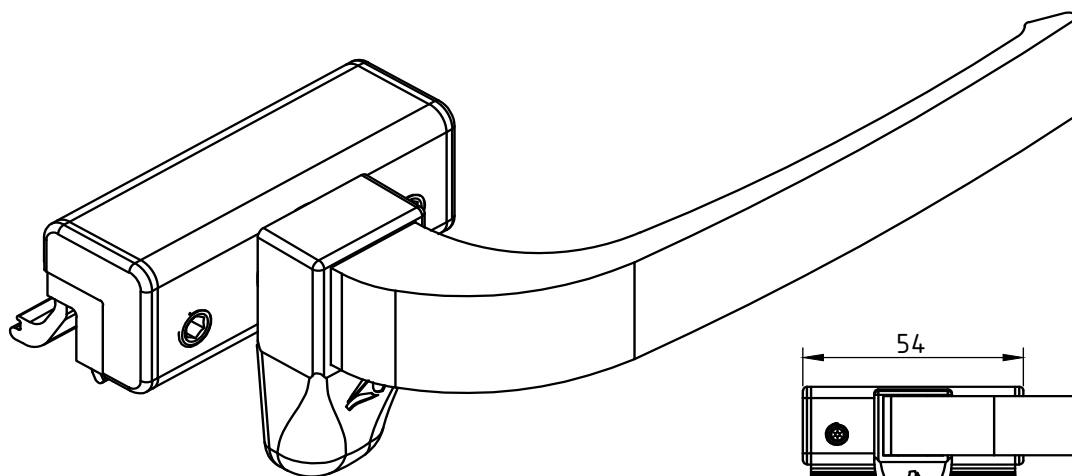

DIMENSÕES:
(escala 1:2)

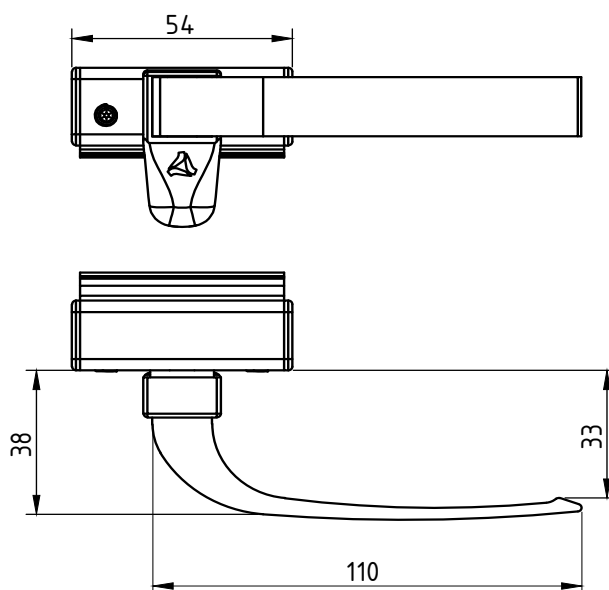

DETALHE DE APLICAÇÃO:
(escala 1:1)

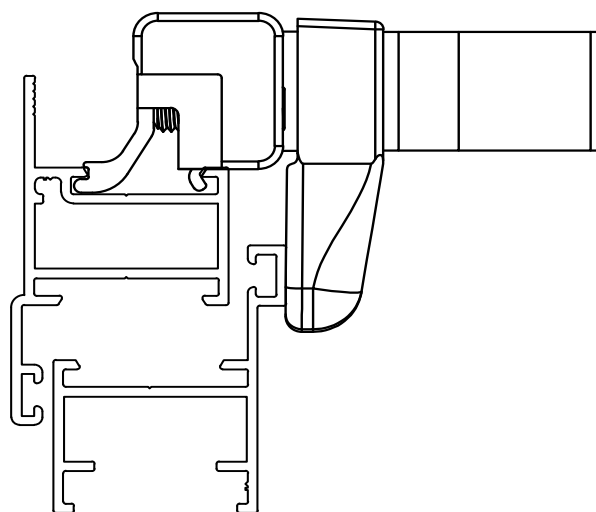

CARACTERÍSTICAS:

Componentes:	Matéria-prima:
Base	Alumínio
Alavanca	Alumínio
Tampas	Poliamida
Trava	Poliamida
Arruela	Aço zincado
Parafusos	Aço Inox

Acabamento Anodizado e Pintado

Preto Fosco Branco

Embalagem	25 Fechos
	50 Tampas
	50 Parafusos

CÓDIGO	ACABAMENTO
FEC-009	Preto
FEC-0090	Fosco
FEC-009EB	Branco

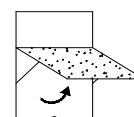

JANELAS
MAXIM-AR

PERSPECTIVA:
(sem escala)

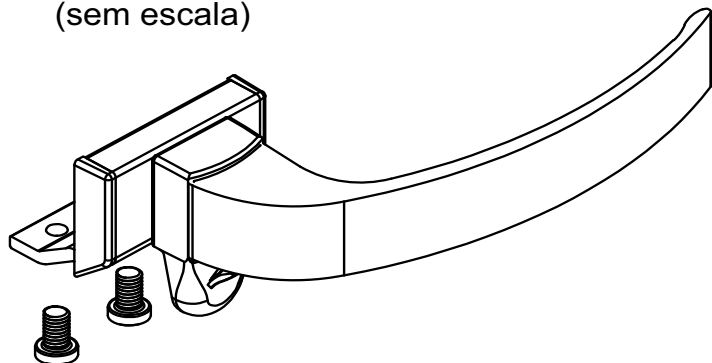

DIMENSÕES:
(escala 1:2)

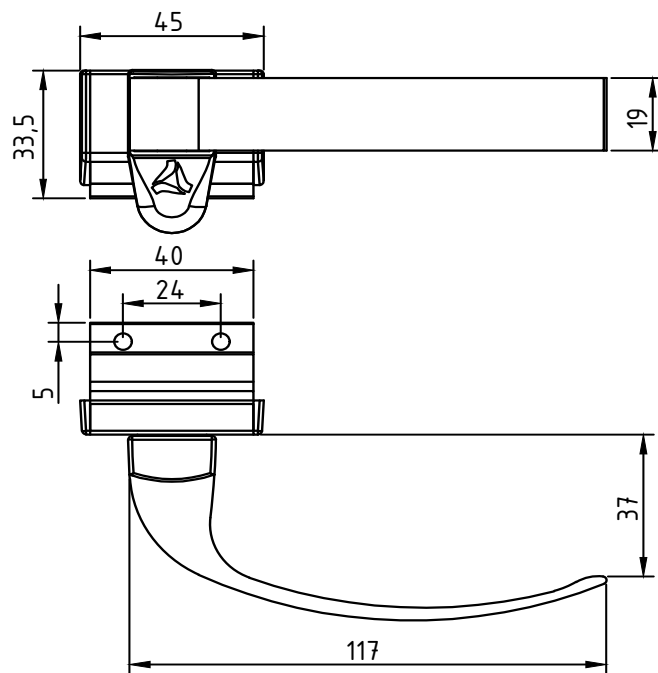

CONTRAFECHO:
(escala 1:1)

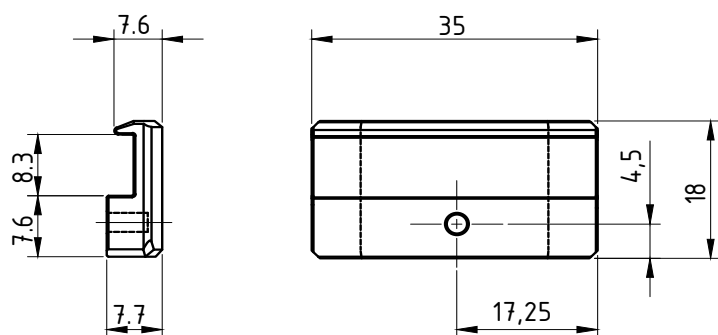

DETALHE DE APLICAÇÃO:
Sem escala

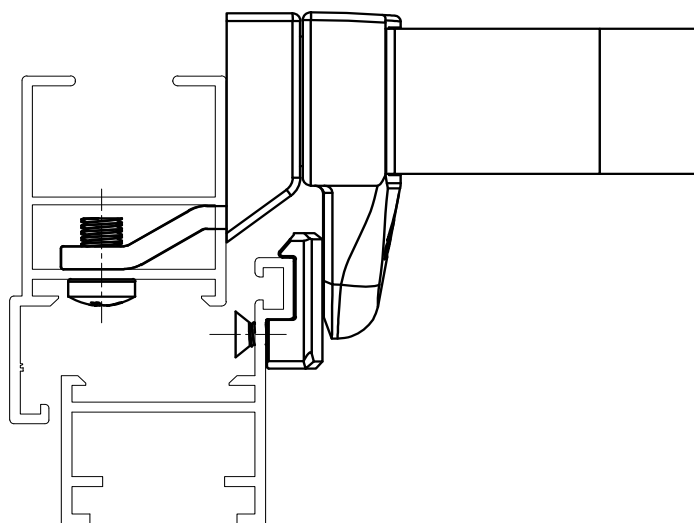

CARACTERÍSTICAS:

Componentes:	Matéria-prima:
Base	Alumínio
Alavanca	Alumínio
Trava	Poliamida
Tampa	Poliamida
Arruela	Aço zincado
Acabamentos	Poliamida
Parafusos	Aço Inox

Acabamento Anodizado e Pintado

Preto

Fosco

Branco

Embalagem

25 Fechos

50 Parafusos

25 Contrafechos

CÓDIGO

ACABAMENTO

FEC-010

Preto

FEC-0100

Fosco

FEC-010EB

Branco

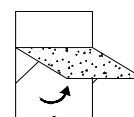

JANELAS
MAXIM-AR

PERSPECTIVA (SEM ESCALA)

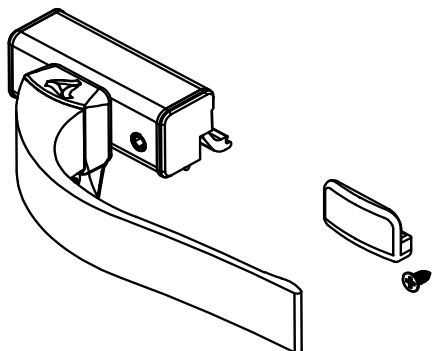

INSTALAÇÃO DO FECHO

1) Encaixe o fecho no perfil da folha conforme figura.

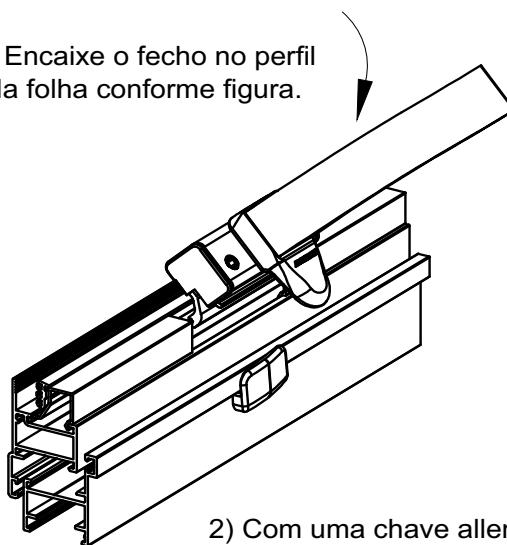

2) Com uma chave allen aperte o parafuso da base para travamento.

DIMENSÕES (ESCALA 1:3)

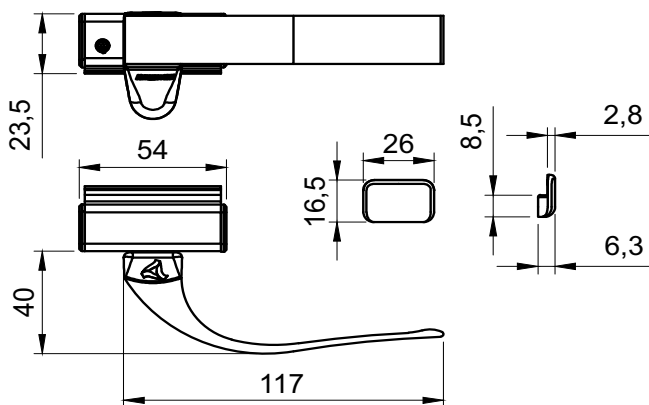

USINAGEM (ESCALA 1:2)

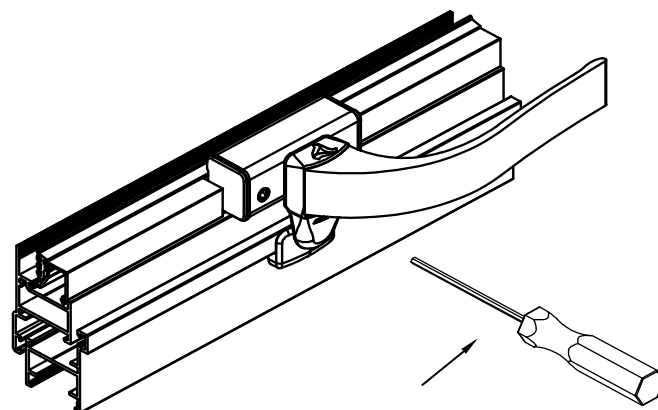
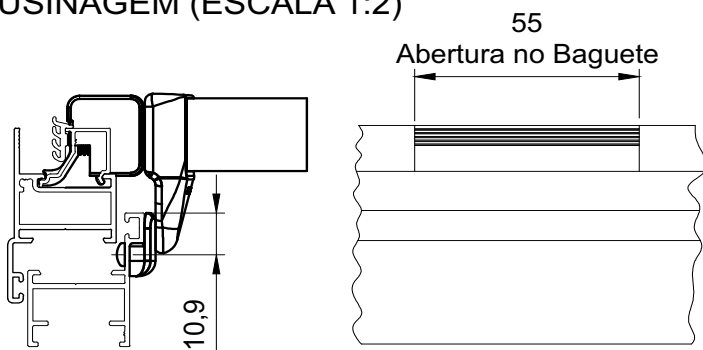

Chave Allen
(Não Fornecido)

INSTALAÇÃO DO CONTRAFECHO

1) Furo o local de instalação.

Chave Phillips
(Não Fornecido)

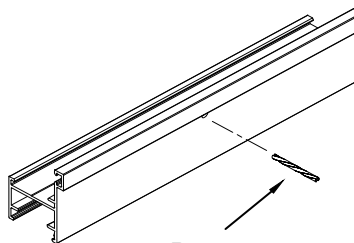

Broca
(Não Fornecido)

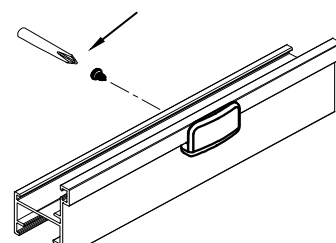

2) Com uma chave phillips fixe o contrafecho.

CARACTERÍSTICAS:

Componentes:	Matéria-prima:
Alavanca - Base	Alumínio
Trava - Tampas	Poliamida
Contrafecho	Poliamida
Arruela	Aço Zincado
Parafusos	Aço Inox

Acabamento Anodizado e Pintado

Preto Fosco Branco

Embalagem 25 Conjuntos

DIREITO	ESQUERDO	ACABAMENTO
FEC-0020FS	FEC-0021FS	Fosco
FEC-0020PT	FEC-0021PT	Preto
FEC-0020BC	FEC-0021BC	Branco
FEC-0020BZ	FEC-0021BZ	Bronze

JANELAS MAXIM-AR

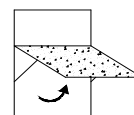

PERSPECTIVA (SEM ESCALA)

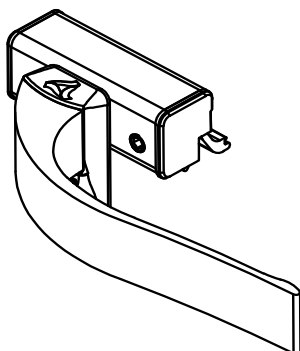

INSTALAÇÃO DO FECHO

1) Encaixe o fecho no perfil da folha conforme figura.

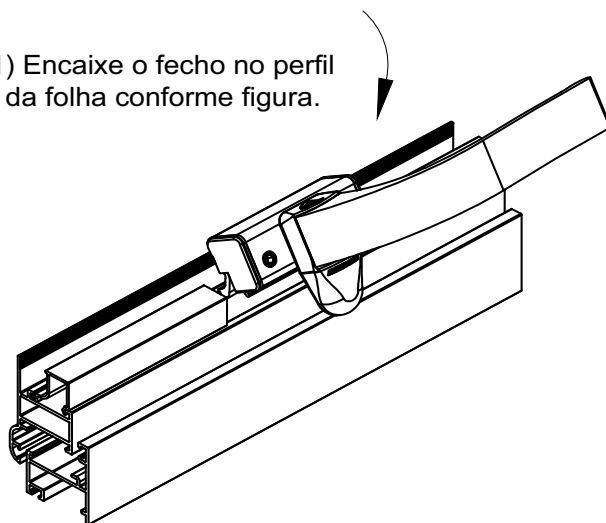

DIMENSÕES (ESCALA 1:3)

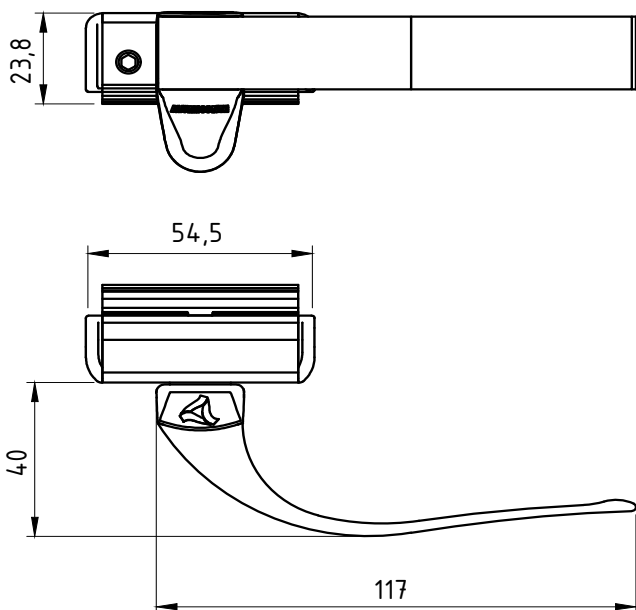

2) Com uma chave allen aperte o parafuso da base para travamento.

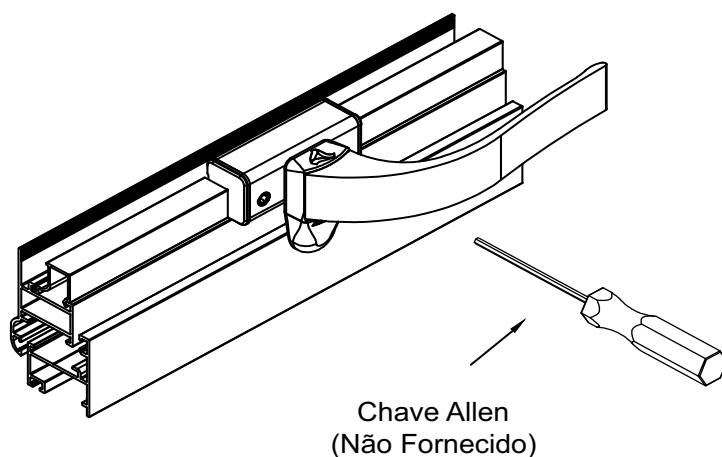

USINAGEM (ESCALA 1:2)

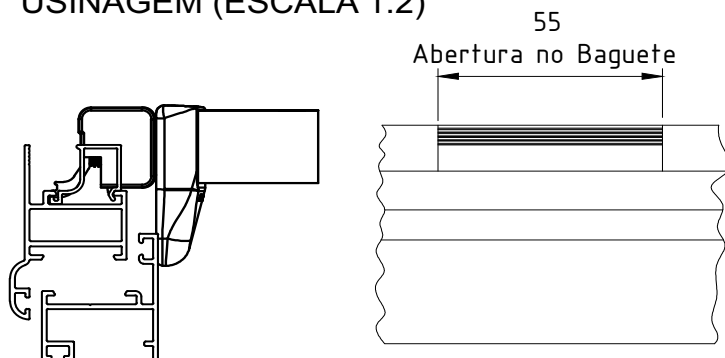

CARACTERÍSTICAS:

Componentes:	Matéria-prima:
Alavanca - Base	Alumínio
Trava	Poliamida
Tampa	Poliamida
Arruela	Aço Zincado
Parafusos	Aço Inox

Acabamento Anodizado e Pintado

Preto	Fosco	Branco
-------	-------	--------

Embalagem	25 Fechos
-----------	-----------

DIREITO	ESQUERDO	ACABAMENTO
FEC-0024FS	FEC-0025FS	Fosco
FEC-0024PT	FEC-0025PT	Preto
FEC-0024BC	FEC-0025BC	Branco
FEC-0024BZ	FEC-0025BZ	Bronze

JANELAS MAXIM-AR

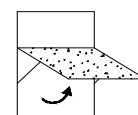



FECHO ALAVANCA
INJETADO
COM BAGUETE

APLICAÇÃO:

ALUK 2.5®

Setembro/2010

PERSPECTIVA:
(escala 1:1)

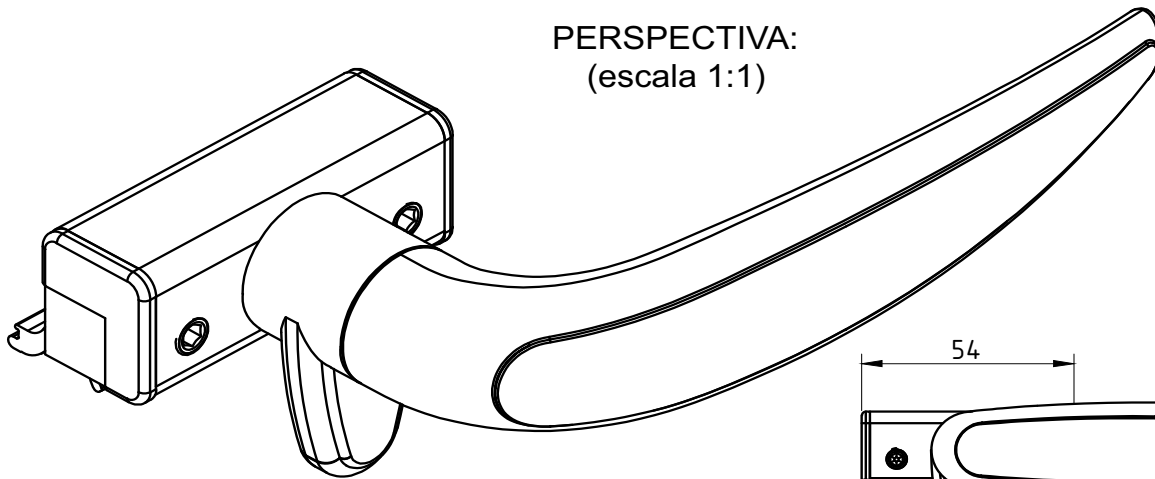

DIMENSÕES:
(escala 1:2)

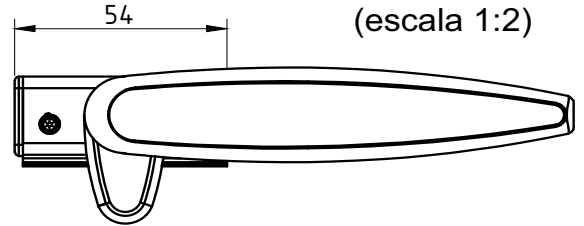

CONTRAFECHO:
(escala 1:1)

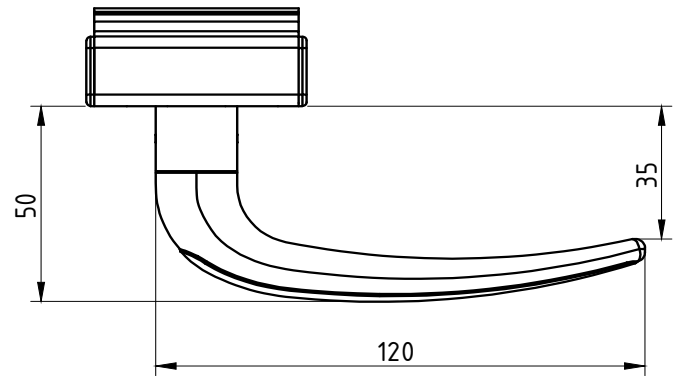
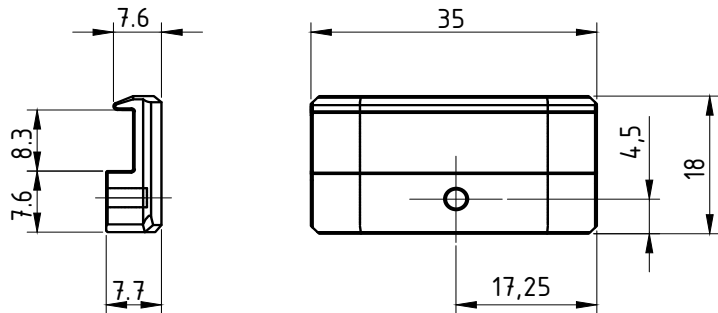

DETALHE DE APLICAÇÃO:
(escala 1:1)

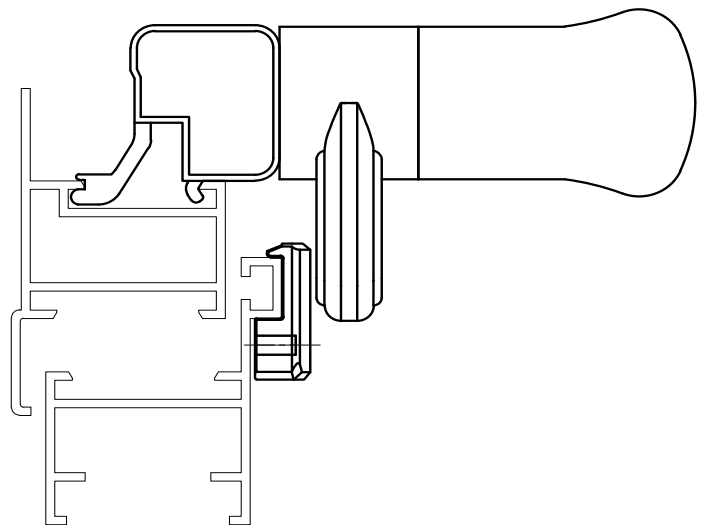

CARACTERÍSTICAS:

Componentes:	Matéria-prima:
Base	Alumínio
Alavanca	Zamac
Tampas	Poliamida
Trava	Zamac
Arruela	Aço Inox
Parafusos	Aço Inox

Acabamento Pintado	
Preto	Branco

Embalagem	10 Fechos
	20 Tampas
	20 Parafusos

CÓDIGO	ACABAMENTO
FEC-600D/P	Preto
FEC-600D/EB	Branco
FEC-600E/P	Preto
FEC-600E/EB	Branco

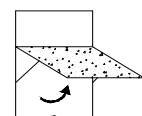

JANELAS
MAXIM-AR

PERSPECTIVA
ESCALA 1:2

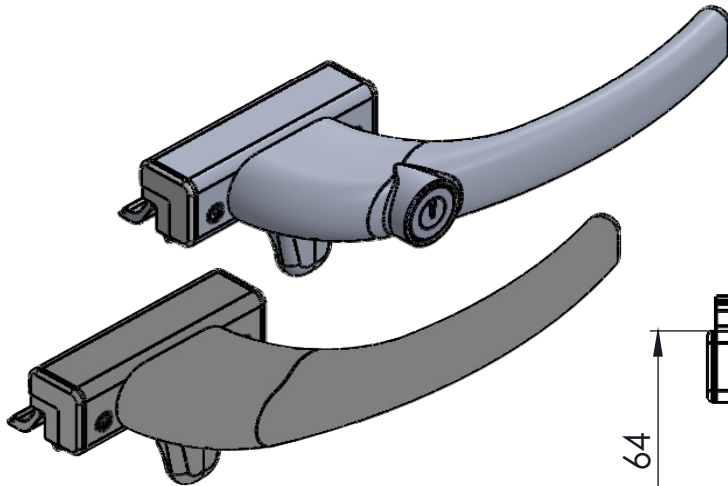

CONTRA FECHO
ESCALA 1:2

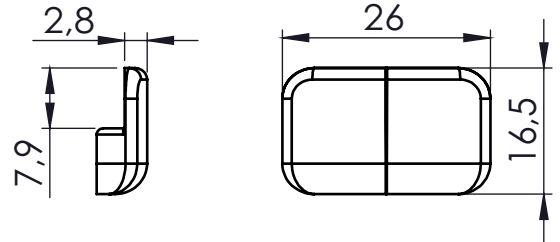

DIMENSÕES
ESCALA 1:2

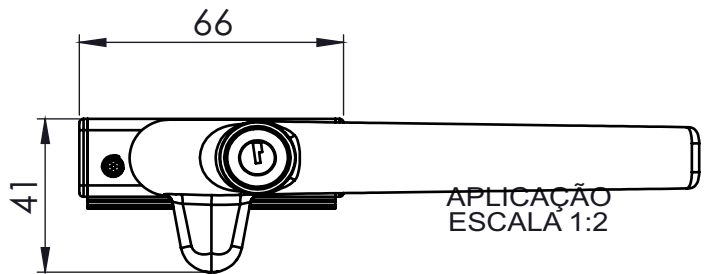
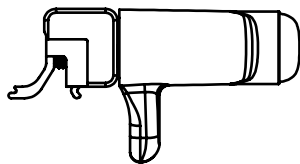
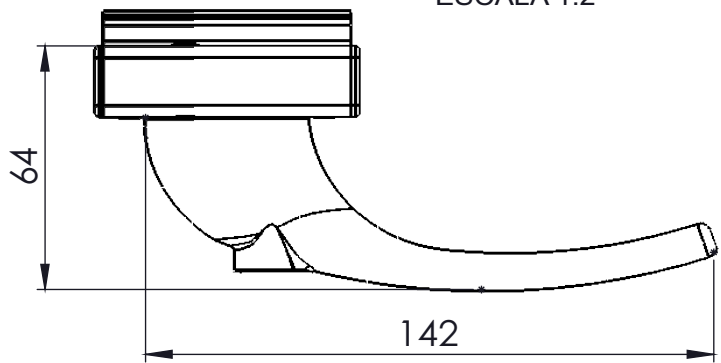

APLICAÇÃO
ESCALA 1:2

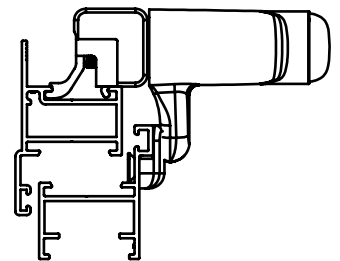

CARACTERÍSTICAS:

Componentes:	Matéria-prima:
Base	Alumínio
Alavanca	Alumínio
Tampas	Poliamida
Trava	Alumínio
Arruela	Poliamida
Parafusos	Aço Inox

Acabamento Pintado	
Branco	Preto

Embalagem	10 Fechos
	10 tampas/contrafechos
	30 Parafusos

CÓDIGO	DESCRIÇÃO
FEC4008BC	Branco s/chave direito
FEC4008PT	Preto s/chave direito
FEC4009BC	Branco s/chave esquerdo
FEC4009PT	Preto s/chave esquerdo
FEC4010BC	Branco c/chave direito
FEC4010PT	Preto c/chave direito
FEC4011BC	Branco c/chave esquerdo
FEC4011PT	Preto c/chave esquerdo



JANELAS
MAXIM-AR

PERSPECTIVA:
(sem escala)

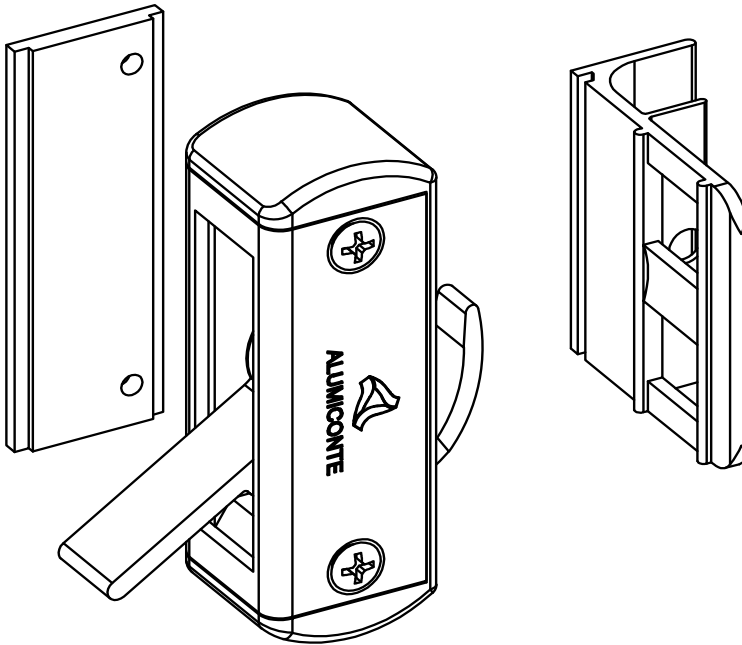

DIMENSÕES:
(escala 1:2)

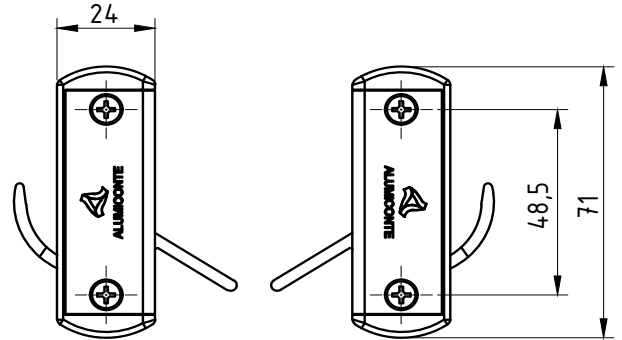

ESQUERDO

DIREITO

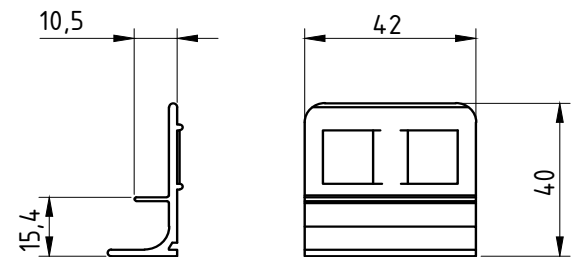

CONTRAFECHO

CARACTERÍSTICAS:

Componentes:	Matéria-prima:
Base	Poliamida
Trinco	Alumínio
Contrafecho	Alumínio
Contrachapa	Alumínio
Acabamentos	Poliamida
Mola	Aço Zincado
Esferas	Aço Inox
Parafusos	Aço Inox

Acabamento Anodizado e Pintado

Preto Fosco Branco

DETALHE DE APLICAÇÃO: (escala 1:2)

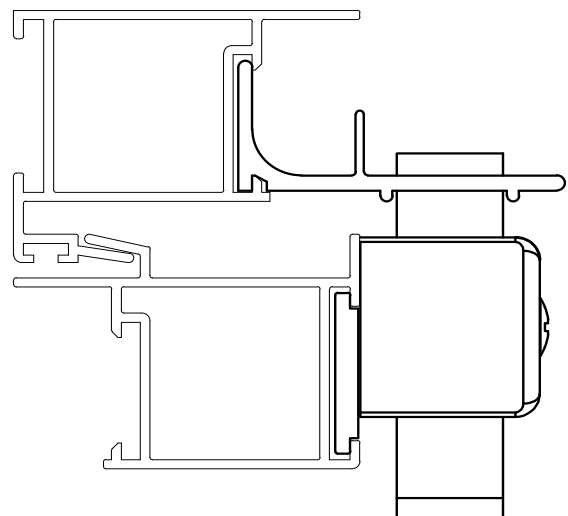

Embalagem

10 Fechos
10 Contrafechos
10 Contrachapas
30 Parafusos

CÓDIGO

ACABAMENTO

FEC-060

Preto

FEC-059

Fosco

FEC-060EB

Branco

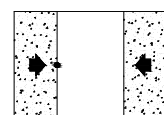

JANELAS
DE CORRER
2 FOLHAS

DIMENSÕES:
(escala 1:2)

PERSPECTIVA:
(sem escala)

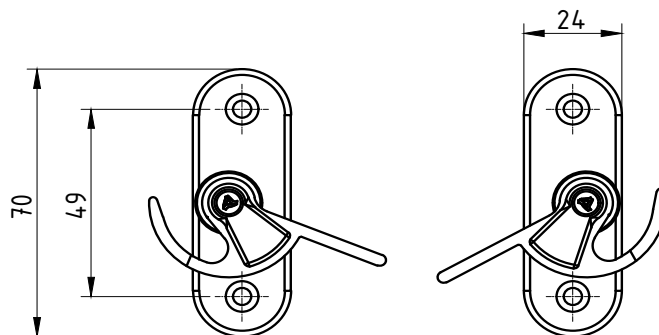
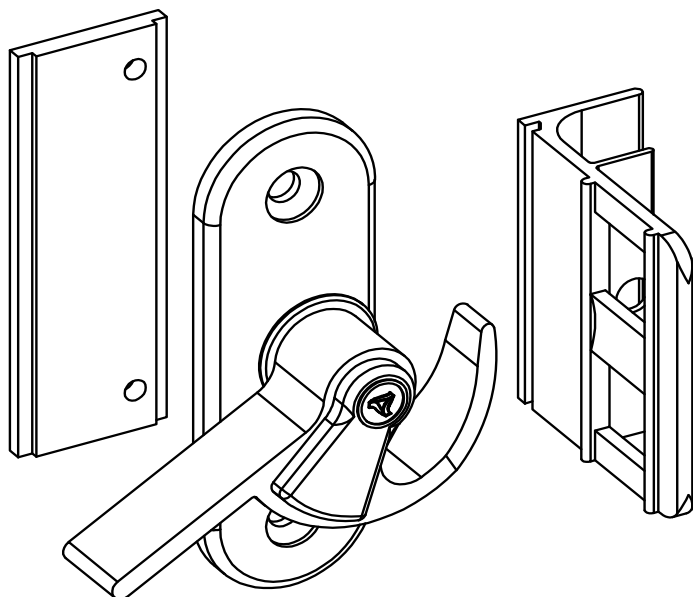

ESQUERDO

DIREITO

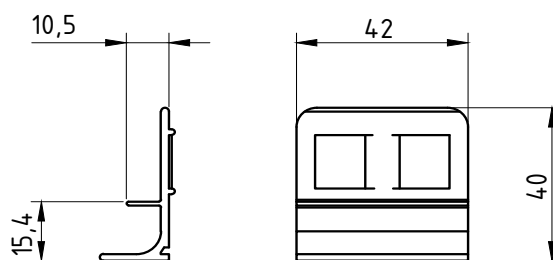

CONTRAFECHO

DETALHE DE APLICAÇÃO:
(escala 1:2)

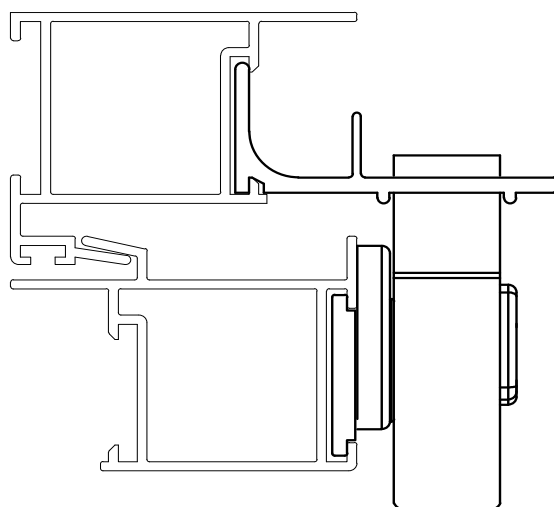

CARACTERÍSTICAS:

Componentes:	Matéria-prima:
Base	Poliamida
Trinco	Alumínio
Contrafecho	Alumínio
Contrachapa	Alumínio
Acabamentos	Poliamida
Parafusos	Aço Inox

Acabamento Anodizado e Pintado

Preto Fosco Branco

Embalagem	10 Fechos
	10 Contrafechos
	10 Contrachapas
	30 Parafusos

CÓDIGO	Especificação
FEC-057PR	Direito/Preto
FEC-057FS	Direito/Fosco
FEC-057EB	Direito/Branco
FEC-063PR	Esquerdo/Preto
FEC-063FS	Esquerdo/Fosco
FEC-063EB	Esquerdo/Branco

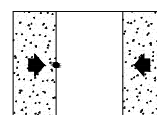

JANELAS
DE CORRER
2 FOLHAS

PERSPECTIVA:
(sem escala)

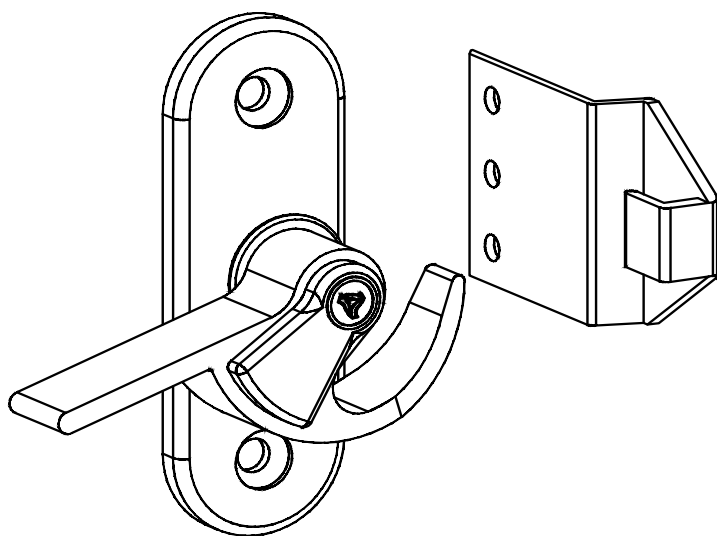

DIMENSÕES:
(escala 1:2)

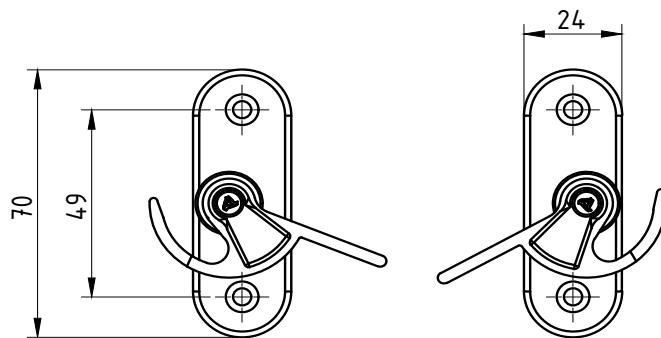

ESQUERDO

DIREITO

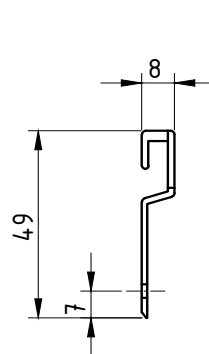

CONTRAFECHO

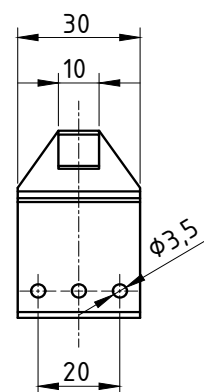

DETALHE DE APLICAÇÃO:
(escala 1:2)

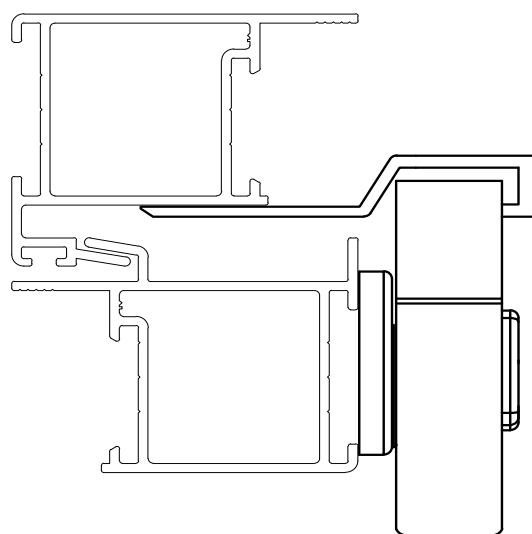

CARACTERÍSTICAS:

Componentes:	Matéria-prima:
Base	Poliamida
Trinco	Alumínio
Contrafecho	Alumínio
Acabamentos	Poliamida
Parafusos	Aço Inox
Rebites	Alumínio

Acabamento Anodizado e Pintado

Preto

Fosco

Branco

Embalagem

10 Fechos
20 Parafusos
10 Contrafechos
30 Rebites

CÓDIGO

ACABAMENTO

FEC 947PR	Direito / Preto
FEC 947FS	Direito / Fosco
FEC 947EB	Direito / Branco
FEC 953PR	Esquerdo / Preto
FEC 953FS	Esquerdo / Fosco
FEC 953EB	Esquerdo / Branco

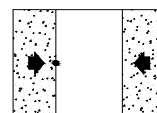

JANELAS
DE CORRER
2 FOLHAS

PERSPECTIVA:
(sem escala)

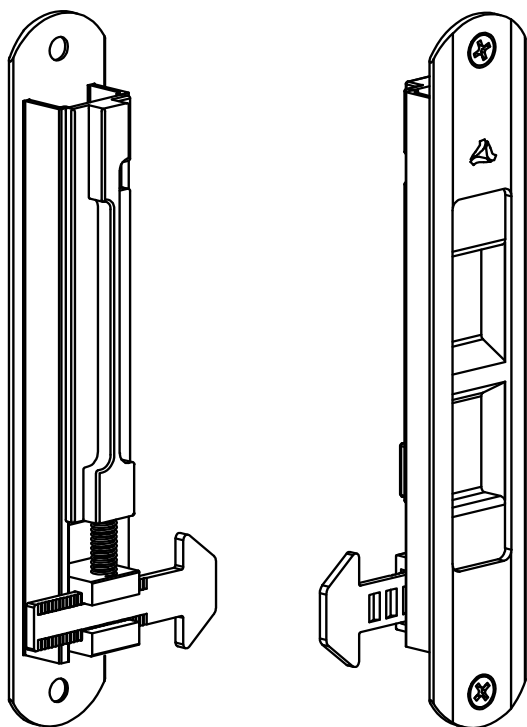

DIMENSÕES:
(escala 1:2)

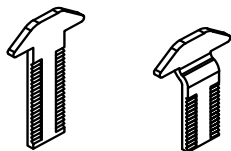
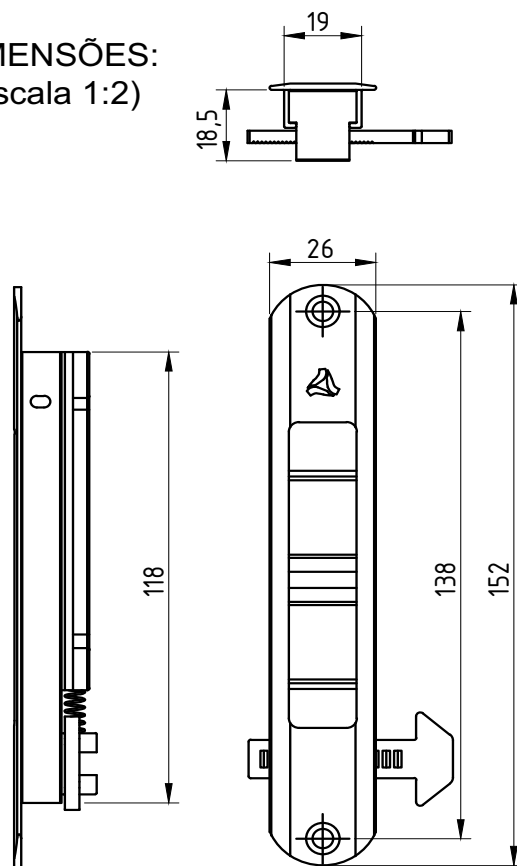

CÓD: LIN-04 CÓD: LIN-03

ATENÇÃO:

VERIFICAR QUAL O TIPO DE
TRAVA IDEAL PARA O PROJETO

DETALHE DE APLICAÇÃO:
(sem escala)

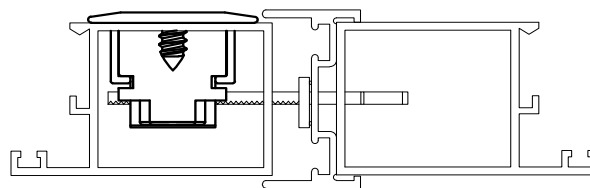
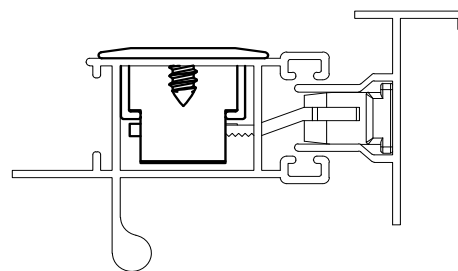

CARACTERÍSTICAS:

Componentes:	Matéria-prima:
Estrutura	Alumínio
Lingueta	Aço Inox
Parafusos	Aço Inox
Mola	Aço Inox
Limitador	Poliamida

Acabamento Anodizado e Pintado

Preto Fosco Branco

Embalagem 20 Fechos
20 Linguetas
40 Parafusos

CÓDIGO	ACABAMENTO
FEC-634 (Manual)	Fosco
FEC-636 (Manual)	Preto
FEC-636EB (Manual)	Branco
FEC-634A (Autom.)	Fosco
FEC-636A (Autom.)	Preto
FEC-636AEB (Autom.)	Branco

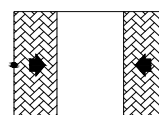

JANELAS
E PORTAS
DE CORRER

PERSPECTIVA:
(sem escala)

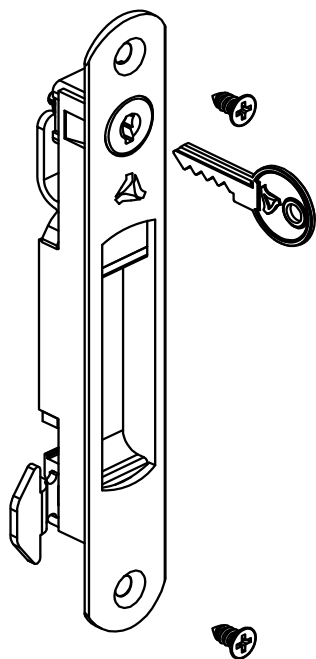

DIMENSÕES:
(escala 1:2)

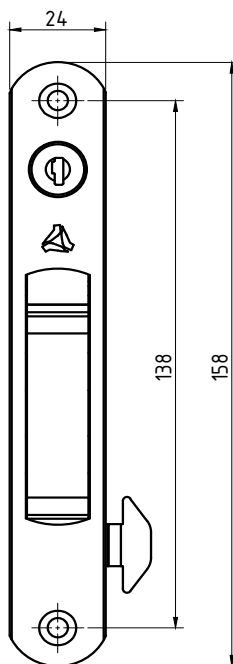
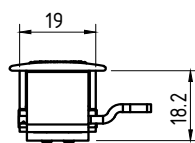
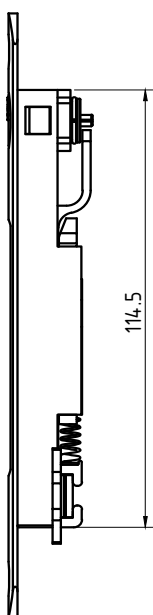

USINAGEM:
(escala 1:2)

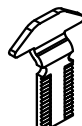
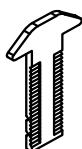
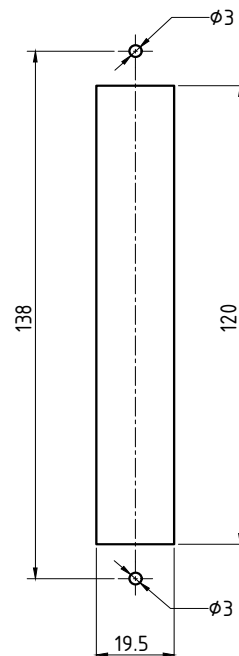

ATENÇÃO:

VERIFICAR QUAL O TIPO DE TRAVA IDEAL PARA O PROJETO

CÓD: LIN-04 CÓD: LIN-03

CARACTERÍSTICAS:

Componentes:	Matéria-prima:
Estrutura	Alumínio
Lingueta	Aço Inox
Parafusos	Aço Inox
Limitador	Poliamida
Acabamentos	Poliamida
Chave	Latão
Cilindro	Zamac

Acabamento Anodizado e Pintado

Preto Fosco Branco

Embalagem 20 Fechos
20 Linguetas
40 Parafusos

DETALHE DE APLICAÇÃO: (sem escala)

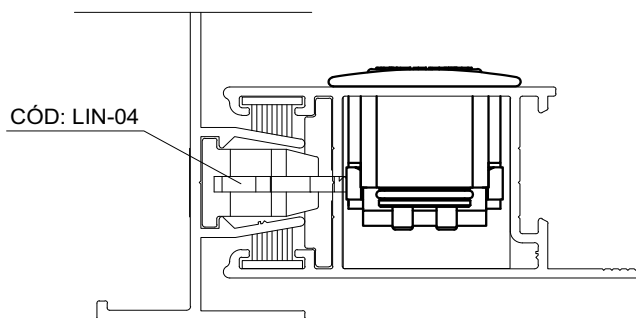

CÓDIGO	ACABAMENTO
FEC-1035 (Manual)	Preto
FEC-10350 (Manual)	Fosco
FEC-1035EB (Manual)	Branco
FEC-1036 (Autom.)	Preto
FEC-10360 (Autom.)	Fosco
FEC-1036EB (Autom.)	Branco

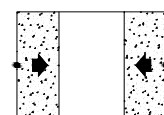

JANELAS E PORTAS DE CORRER

PERSPECTIVA:
(sem escala)

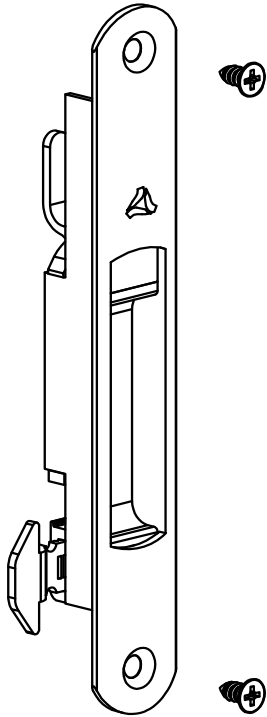

(escala 1:2)

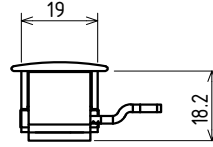
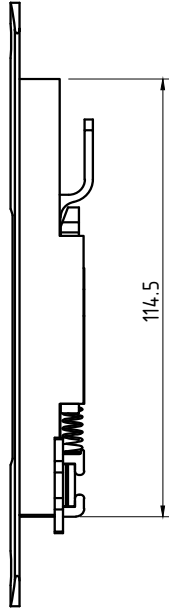

USINAGEM:
(escala 1:2)

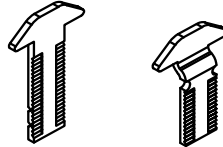
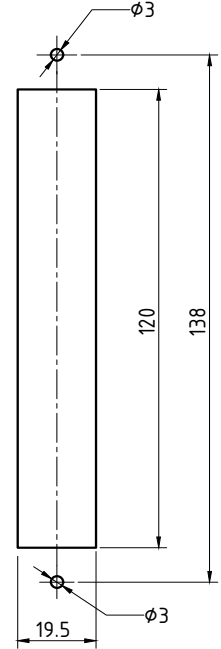
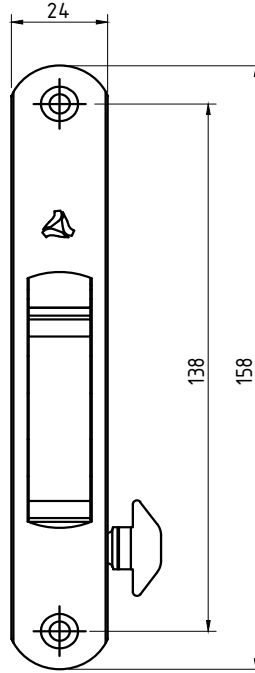

VERIFICAR QUAL O TIPO DE TRAVA IDEAL PARA O PROJETO

(sem escala)

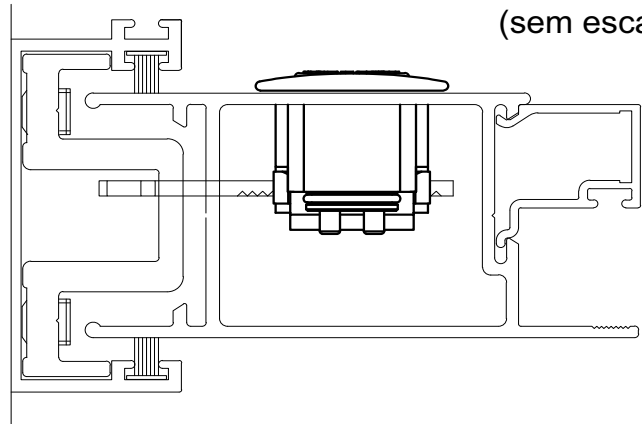

Componentes:

Matéria-prima:

Estrutura

Alumínio

Lingueta

Aço Inox

Parafusos

Aço Inox

Limitador

Poliamida

Acabamentos

Poliamida

Acabamento Anodizado e Pintado

Preto

Fosco

Branco

CÓDIGO

ACABAMENTO

FEC-1037 (Manual)

Preto

FEC-10370 (Manual)

Fosco

FEC-1037EB (Manual)

Branco

FEC-1038 (Autom.)

Preto

FEC-10380 (Autom.)

Fosco

FEC-1038EB (Autom.)

Branco

Embalagem

20 Fechos

20 Linguetas

40 Parafusos

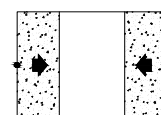

JANELAS
E PORTAS
DE CORRER

PERSPECTIVA:
(sem escala)

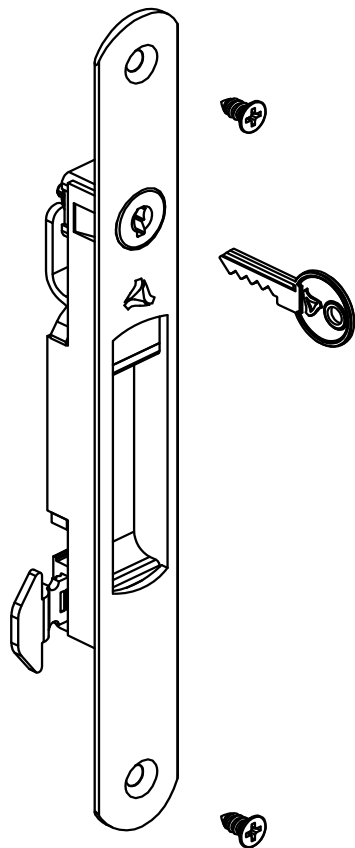

(escala 1:2)

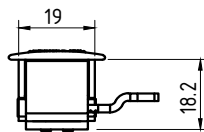
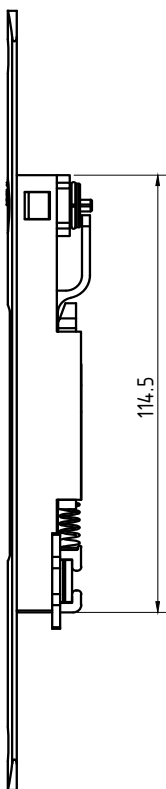

USINAGEM:
(escala 1:2)

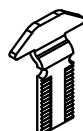
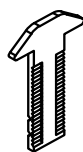
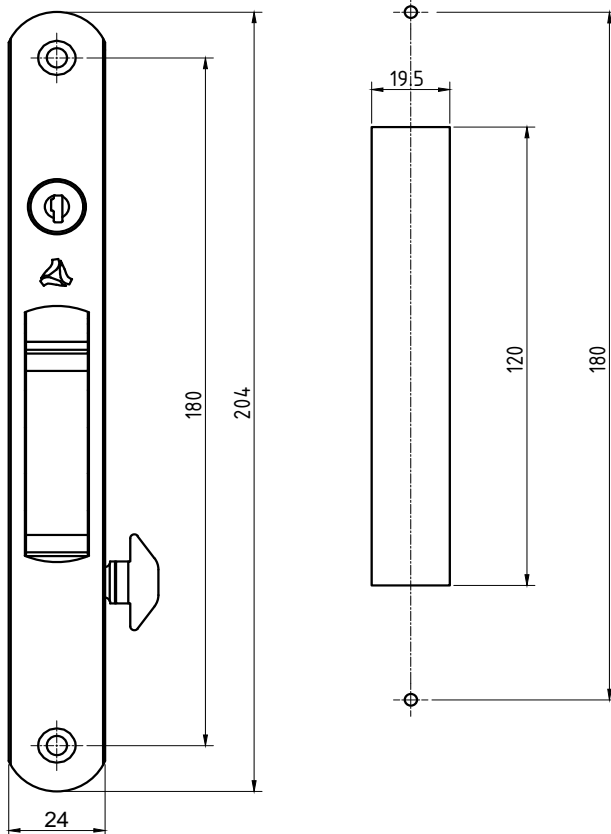

VERIFICAR QUAL O TIPO DE TRAVA IDEAL PARA O PROJETO

Componentes:

Matéria-prima:

Estrutura

Alumínio

Lingueta

Aço Inox

Parafusos

Aço Inox

Limitador

Poliamida

Acabamentos

Poliamida

Chave

Latão

Cilindro

Zamac

Acabamento Anodizado e Pintado

Preto

Fosco

Branco

Embalagem

20 Fechos

20 Linguetas

40 Parafusos

(sem escala)

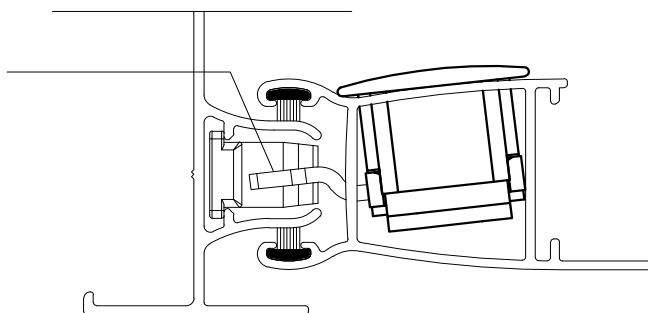

CÓDIGO

ACABAMENTO

FEC-1039 (Manual)

Preto

FEC-10390 (Manual)

Fosco

FEC-1039EB (Manual)

Branco

FEC-1040 (Autom.)

Preto

FEC-10400 (Autom.)

Fosco

FEC-1040EB (Autom.)

Branco

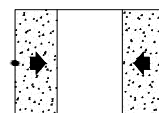

JANELAS
E PORTAS
DE CORRER

PERSPECTIVA:
(sem escala)

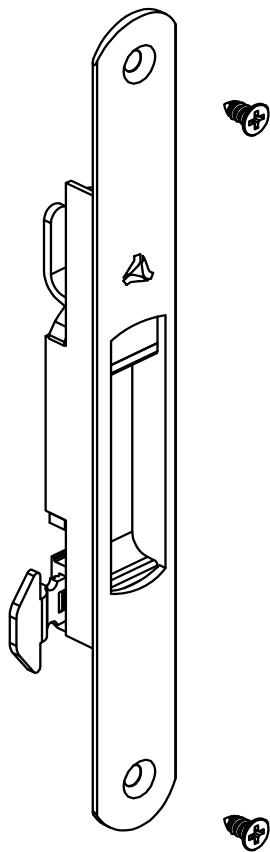

(escala 1:2)

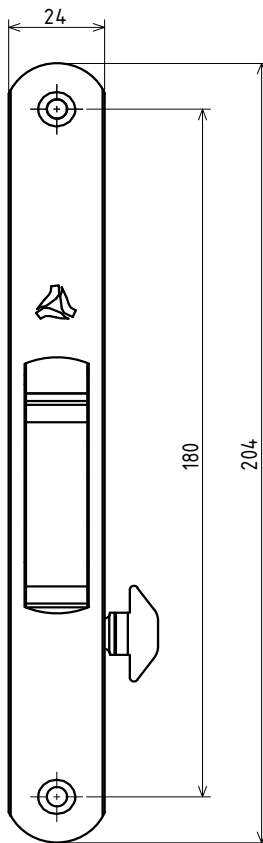
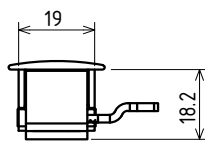
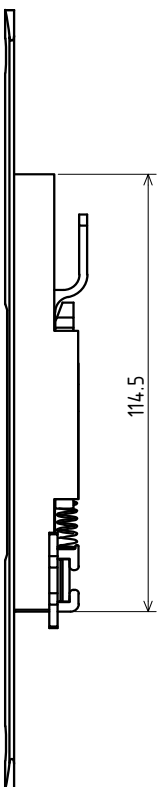

USINAGEM:
(escala 1:2)

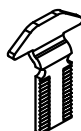
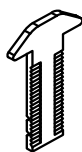
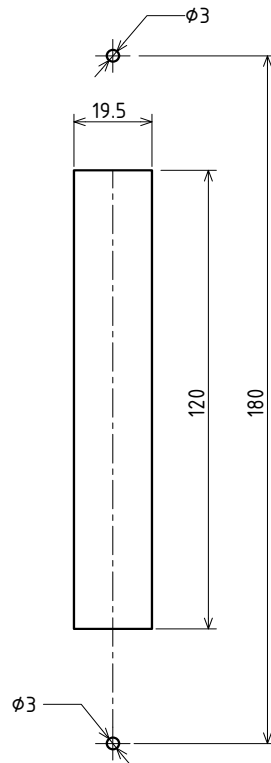

VERIFICAR QUAL O TIPO DE TRAVA IDEAL PARA O PROJETO

(sem escala)

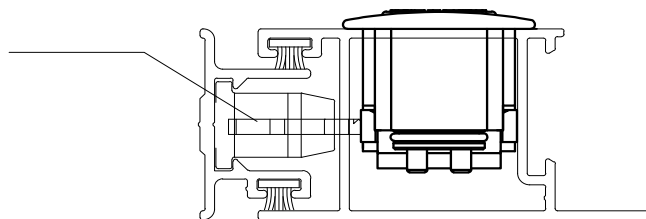

Componentes:	Matéria-prima:
Estrutura	Alumínio
Lingueta	Aço Inox
Parafusos	Aço Inox
Limitador	Poliamida
Acabamentos	Poliamida

Acabamento Anodizado e Pintado		
Preto	Fosco	Branco

Embalagem	20 Fechos
	20 Linguetas
	40 Parafusos

CÓDIGO	ACABAMENTO
FEC-1041 (Manual)	Preto
FEC-10410 (Manual)	Fosco
FEC-1041EB (Manual)	Branco
FEC-1042 (Autom.)	Preto
FEC-10420 (Autom.)	Fosco
FEC-1042EB (Autom.)	Branco

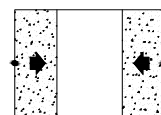

JANELAS
E PORTAS
DE CORRER

PERSPECTIVA:
(sem escala)

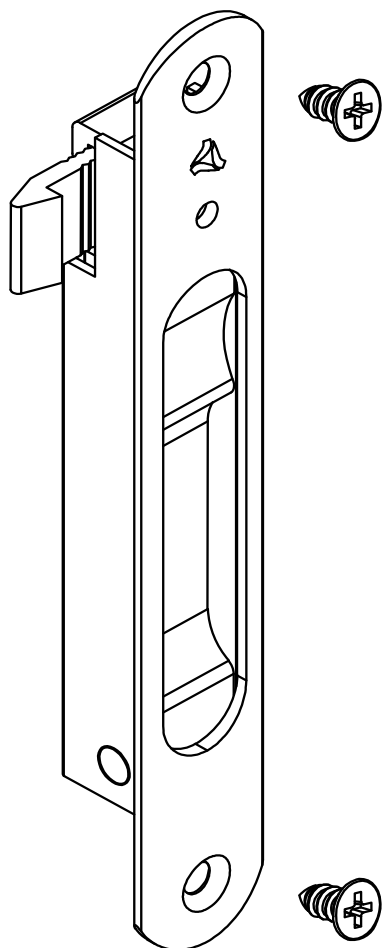

(escala 1:2)

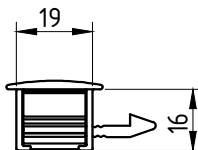
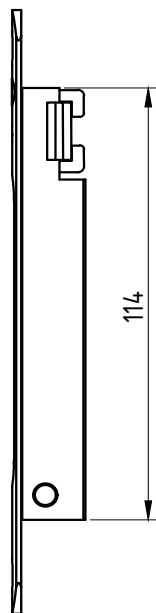

USINAGEM:
(escala 1:2)

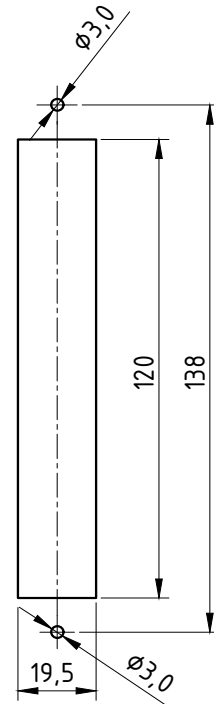
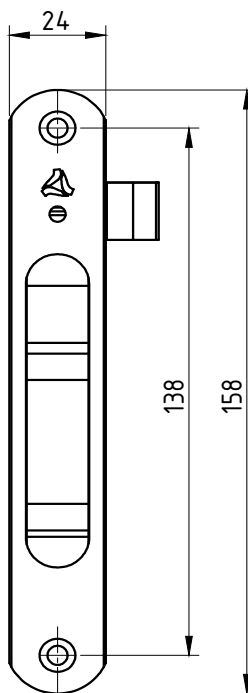

PERFIL- MARCO LATERAL
VENDIDO SEPARADAMENTE
Obs: Verificar a linha indicada para a

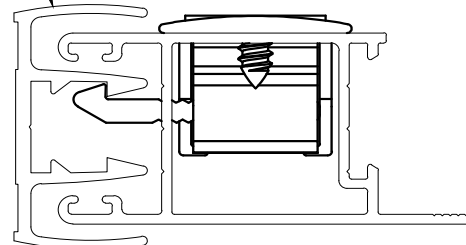

(escala 1:1)

Componentes:	Matéria-prima:
Estrutura	Alumínio
Lingueta	Alumínio
Parafusos	Aço Inox
Mola	Aço Mola
Eixo de centro	Alumínio

Acabamento Anodizado e Pintado			
Preto	Fosco	Branco	Bronze

Embalagem	20 Fechos
	20 Linguetas
	40 Parafusos

CÓDIGO	ACABAMENTO
FEC-250	Preto
FEC-2500	Fosco
FEC-250EB	Branco
FEC-250BR	Bronze

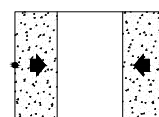

JANELAS
E PORTAS
DE CORRER

Janeiro/2005

PERSPECTIVA
(sem escala)

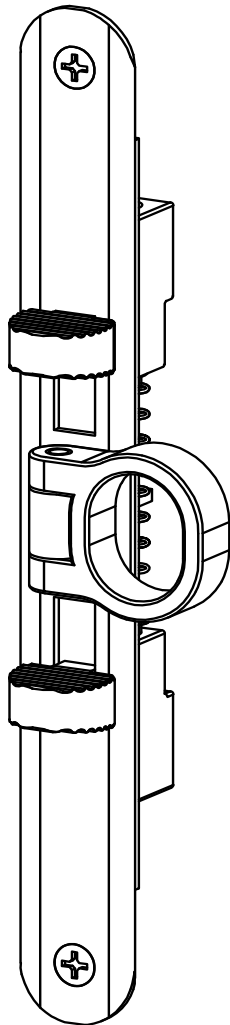

Guias e Alça
somente em preto

DIMENSÕES:
(escala 1:2)

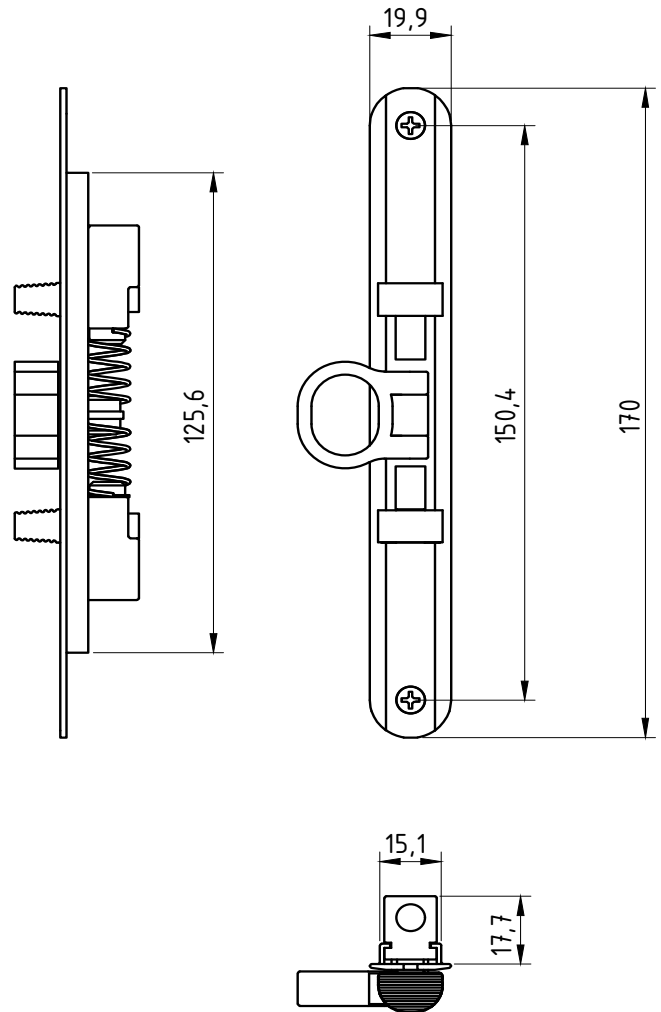

DETALHE DE APLICAÇÃO
(escala 1:1)

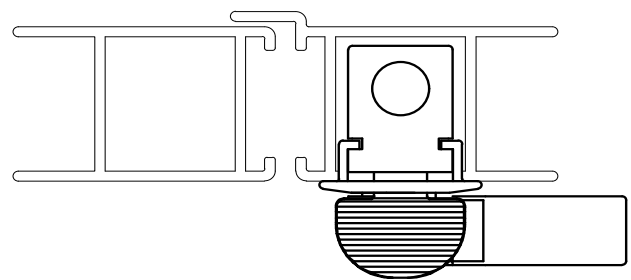

CARACTERÍSTICAS:

Componentes:	Matéria-prima:
Base	Alumínio
Guias	Poliamida
Alça	Poliamida
Parafusos	Aço Inox
Molas	Aço Zincado

Acabamento Anodizado e Pintado		
Preto	Fosco	Branco

Embalagem	20 Fechos
	40 Parafusos

CÓDIGO	ACABAMENTO
FEC-695	Preto
FEC-694	Fosco
FEC-695EB	Branco

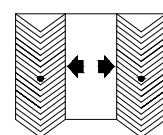

JANELAS
E PORTAS
CAMARÃO

PERSPECTIVA:
(sem escala)

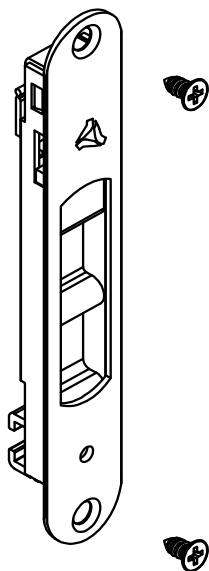

DIMENSÕES:
(escala 1:2)

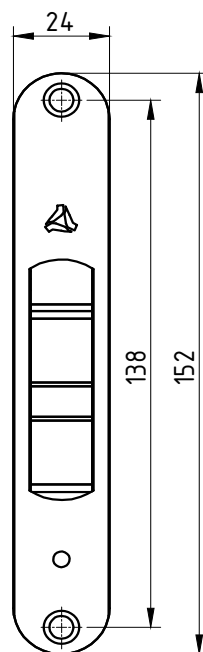
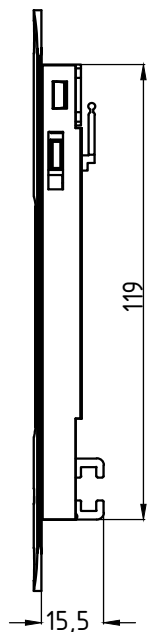

USINAGEM:
(escala 1:2)

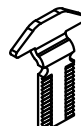
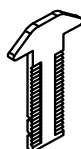
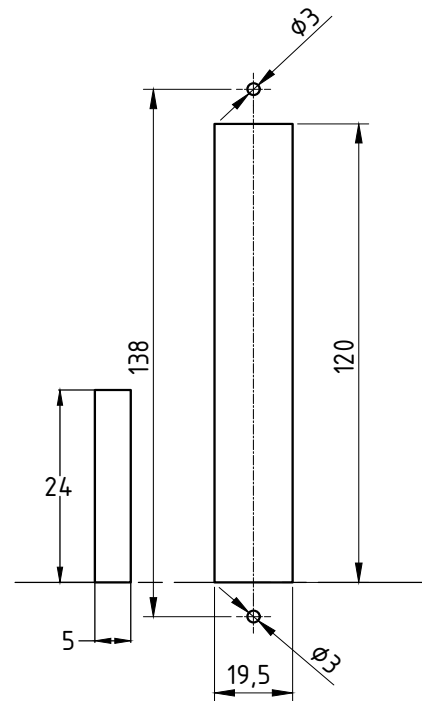

ATENÇÃO:

VERIFICAR QUAL O TIPO DE
TRAVA IDEAL PARA O PROJETO

CÓD: LIN-04 CÓD: LIN-03

DETALHE DE APLICAÇÃO:
(sem escala)

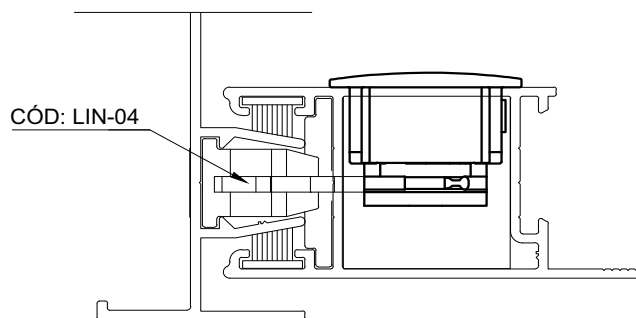

CARACTERÍSTICAS:

Componentes:	Matéria-prima:
Estrutura	Alumínio
Lingueta	Aço Inox
Parafusos	Aço Inox
Limitador	Poliamida

Acabamento Anodizado e Pintado

Preto Fosco Branco

Embalagem

20 Fechos
20 Linguetas
40 Parafusos

CÓDIGO	ACABAMENTO
FEC-200 (Manual)	Preto
FEC-2000 (Manual)	Fosco
FEC-200EB (Manual)	Branco
FEC-201 (Autom.)	Preto
FEC-2010 (Autom.)	Fosco
FEC-201EB (Autom.)	Branco

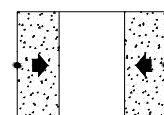

JANELAS
E PORTAS
DE CORRER

PERSPECTIVA:
(sem escala)

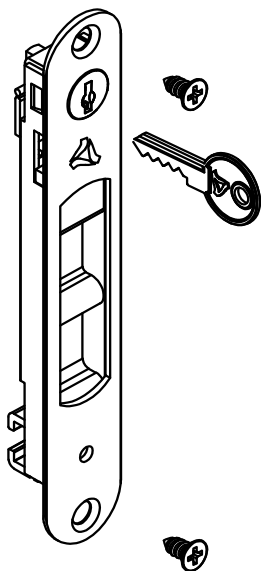

DIMENSÕES:
(escala 1:2)

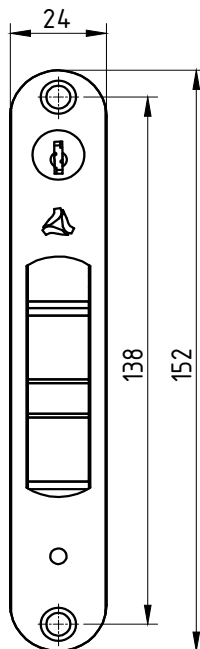
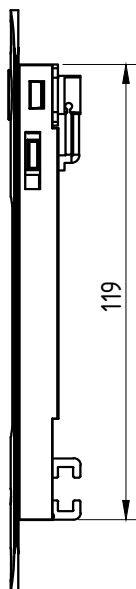

USINAGEM:
(escala 1:2)

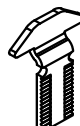
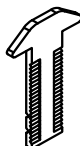
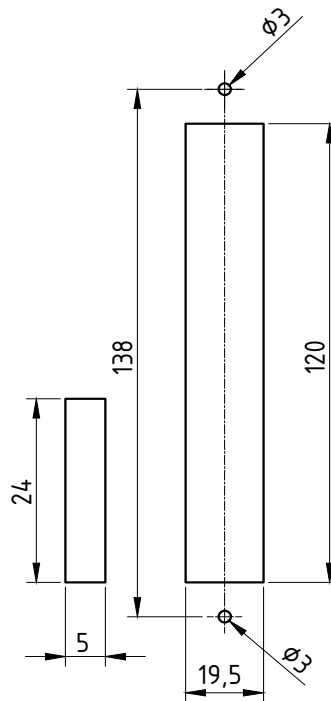

ATENÇÃO:

VERIFICAR QUAL O TIPO DE
TRAVA IDEAL PARA O PROJETO

CÓD: LIN-04 CÓD: LIN-03

CARACTERÍSTICAS:

Componentes:	Matéria-prima:
Estrutura	Alumínio
Lingueta	Aço Inox
Parafusos	Aço Inox
Limitador	Poliamida
Chave	Latão
Cilindro	Zamac

Acabamento Anodizado e Pintado

Preto Fosco Branco

Embalagem

20 Fechos
20 Linguetas
40 Parafusos

DETALHE DE APLICAÇÃO:
(sem escala)

CÓD: LIN-04

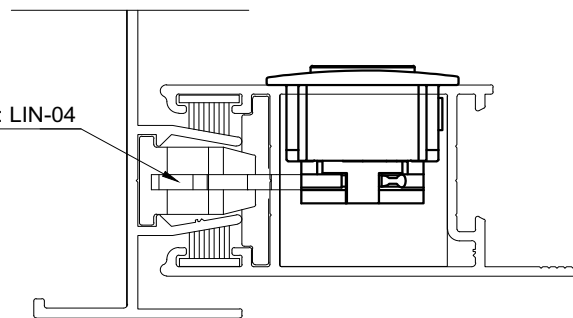

CÓDIGO	ACABAMENTO
FEC-202 (Manual)	Preto
FEC-2020 (Manual)	Fosco
FEC-202EB (Manual)	Branco
FEC-203 (Autom.)	Preto
FEC-2030 (Autom.)	Fosco
FEC-203EB (Autom.)	Branco

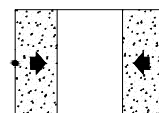

JANELAS
E PORTAS
DE CORRER

PERSPECTIVA:
(sem escala)

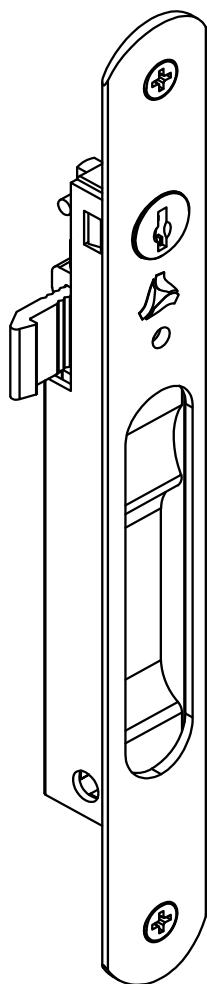

USINAGEM:
(escala 1:2)

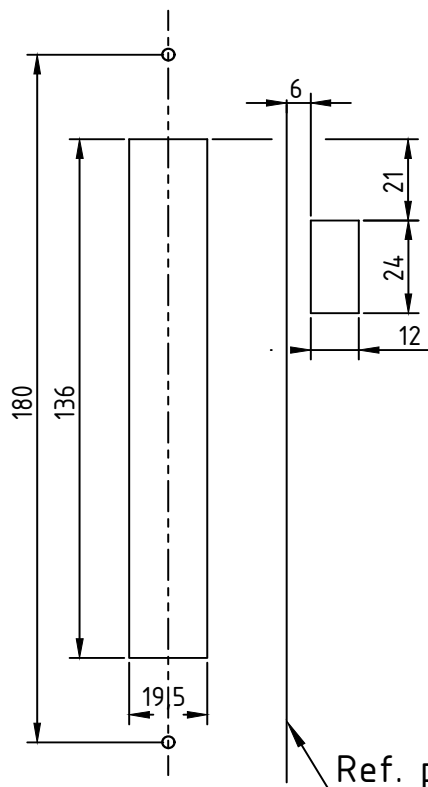

(escala 1:2)

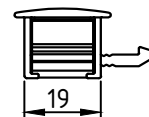
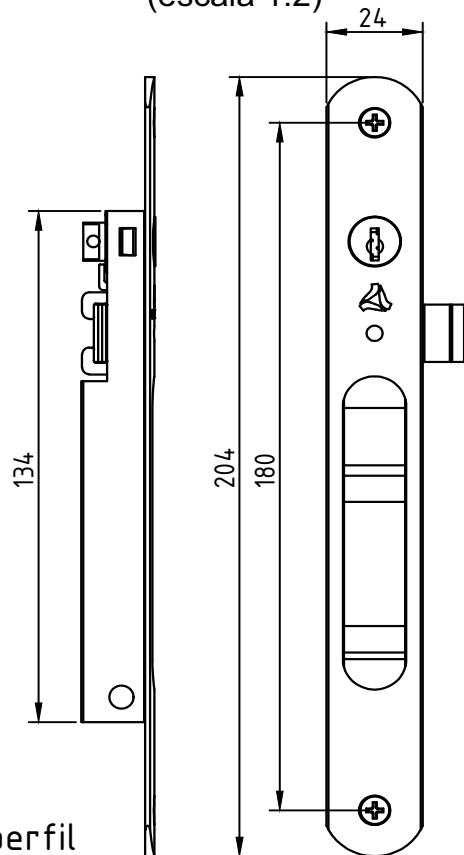

PERFIL- MARCO LATERAL
VENDIDO SEPARADAMENTE
Obs: Verificar a linha indicada para a

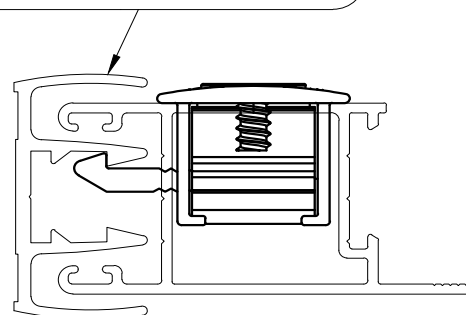

(escala 1:1)

Componentes:

Matéria-prima:

Estrutura	Alumínio
Chave	Aço Aniquelado
Lingueta	Alumínio
Parafusos	Aço Inox
Mola	Aço Mola
Eixo de centro	Alumínio

Acabamento Anodizado e Pintado

Preto Fosco Branco Bronze

Embalagem	20 Fechos com chave
	20 Linguetas
	40 Parafusos

CÓDIGO ACABAMENTO

FEC-0255PT	Preto
FEC-0255FS	Fosco
FEC-0255BC	Branco
FEC-0255BR	Bronze

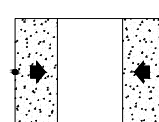

JANELAS
E PORTAS
DE CORRER

PERSPECTIVA:
(sem escala)

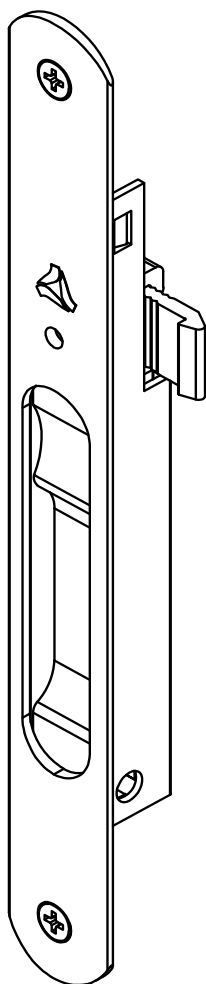

USINAGEM:
(escala 1:2)

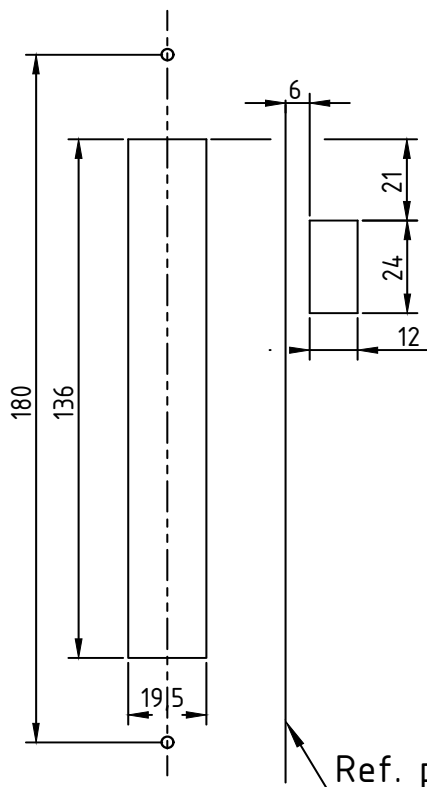

(escala 1:2)

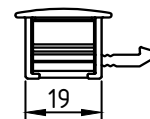
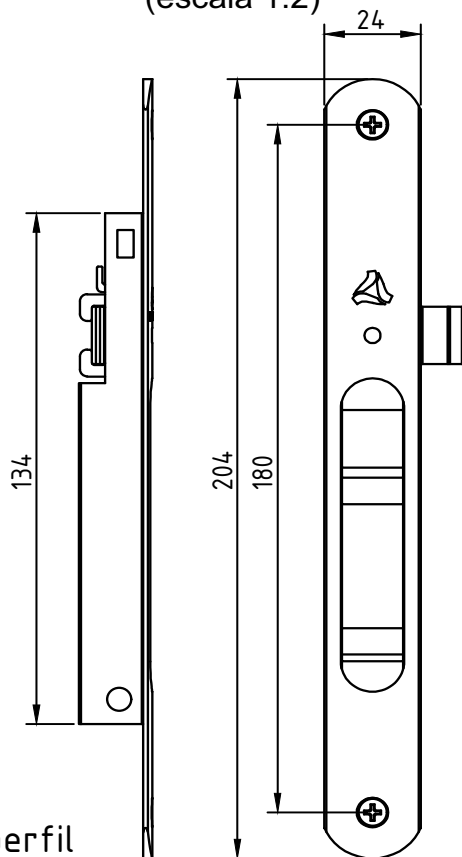

PERFIL- MARCO LATERAL
VENDIDO SEPARADAMENTE
Obs: Verificar a linha indicada para a

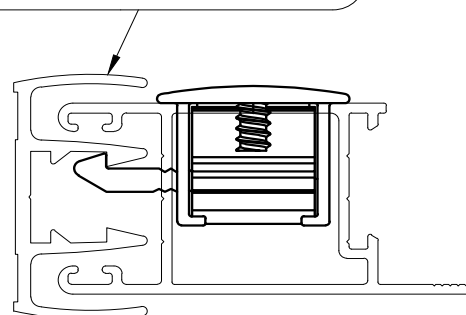

(escala 1:1)

Componentes:

Matéria-prima:

Estrutura

Alumínio

Lingueta

Alumínio

Parafusos

Aço Inox

Mola

Aço Mola

Eixo de centro

Alumínio

Acabamento Anodizado e Pintado

Preto

Fosco

Branco

Bronze

Embalagem

20 Fechos

20 Linguetas

40 Parafusos

CÓDIGO

ACABAMENTO

FEC-0254PT

Preto

FEC-0254FS

Fosco

FEC-0254BC

Branco

FEC-0254BR

Bronze

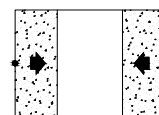

JANELAS
E PORTAS
DE CORRER

Novembro/2015

(escala 1:1)

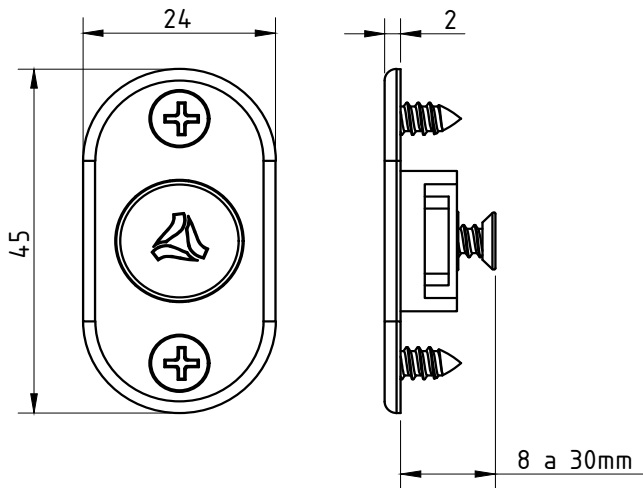

USINAGEM 1:
(escala 1:2)

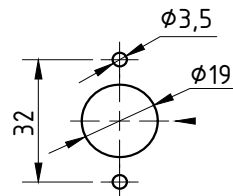

(sem escala)

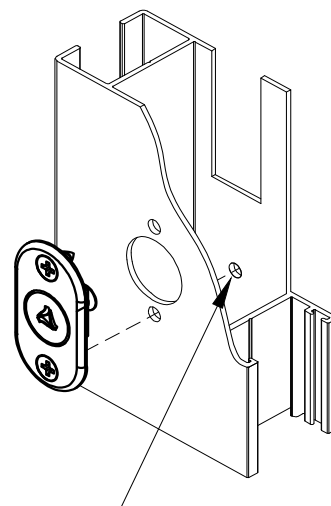

(sem escala)

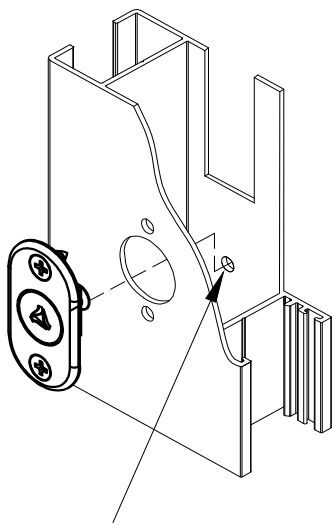

(escala 1:1)

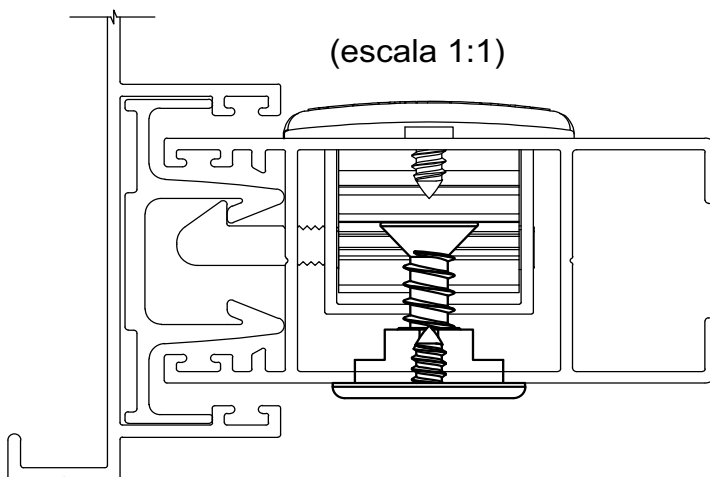

Componentes:	Matéria-prima:
Base	Poliamida
Pino	Poliamida
Parafusos	Aço Inox

Acabamento	
Preto	Branco

Embalagem	01Acionador
	04 Parafusos

CÓDIGO	ACABAMENTO
FEC-0400PT	Preto
FEC-0400BC	Branco

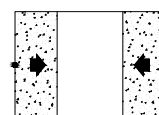

JANELAS
E PORTAS
DE CORRER

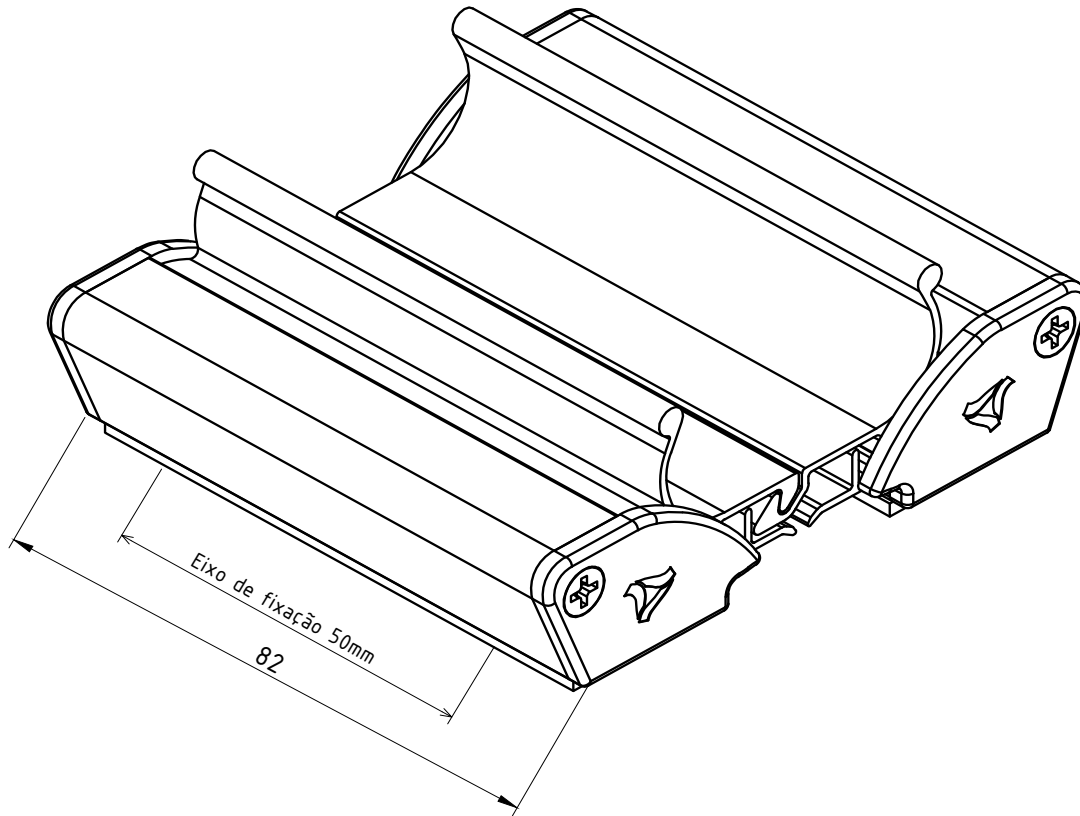

DETALHE DE APLICAÇÃO:
(sem escala)

ACIONAMENTO

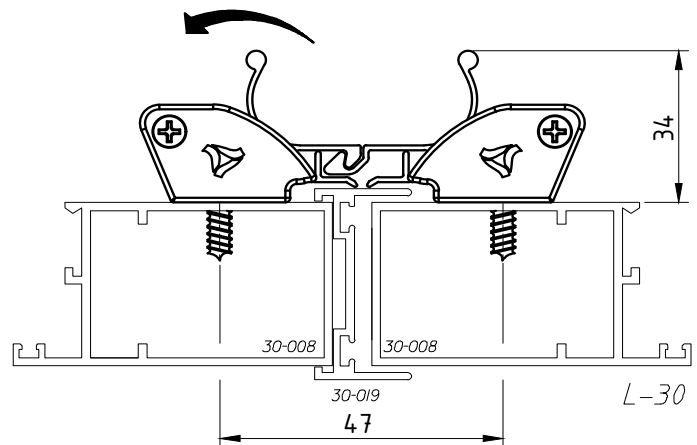

CARACTERÍSTICAS:

Componentes:	Matéria-prima:
Estrutura	Alumínio
Parafusos	Aço Inox
Acabamentos	Nylon Preto
Mola	Aço Mola

Acabamento		
Preto	Branco	Fosco

Embalagem	01 Puxador
	01 Mola
	08 Parafusos
	04 Tampas

CÓDIGO	ACABAMENTO
FEC311P	Preto
FEC311EB	Branco
FEC311FS	Fosco

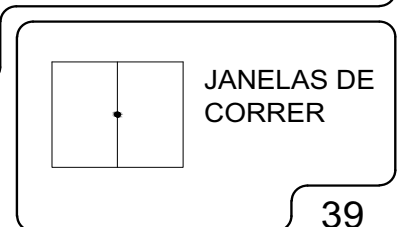

Julho 2011

DIMENSÕES:
(escala 1:2)

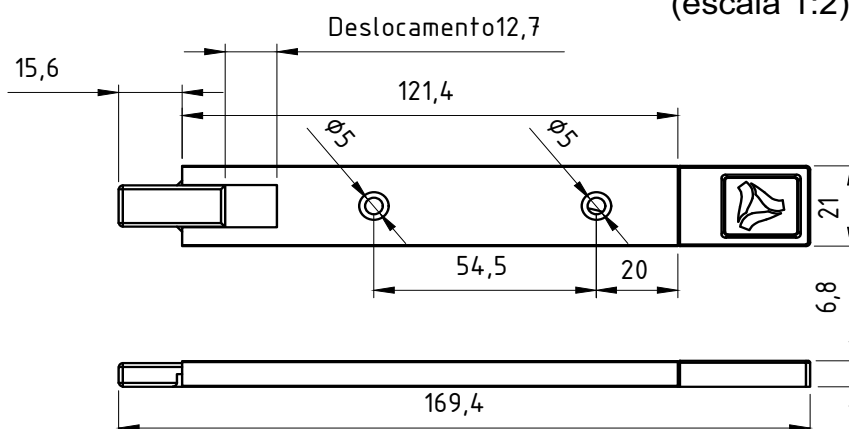

DETALHE DE APLICAÇÃO:
(sem escala)

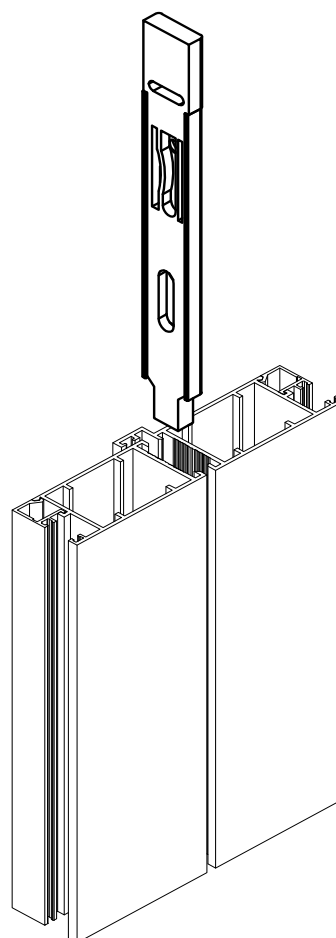

PERSPECTIVA:
(sem escala)



CARACTERÍSTICAS:

Componentes:	Matéria-prima:
Capa	Alumínio
Interno	Poliamida
Parafuso	Aço inox

Acabamentos

Preto	Fosco	Branco
-------	-------	--------

Embalagem

2 Peças
4 Parafusos

CÓDIGO	ACABAMENTO
FEC-338	Preto
FEC-3380	Fosco
FEC-338EB	Branco

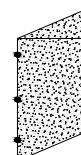

PORTA DE GIRO

Julho/2006

PERSPECTIVA:
(escala 1,5:1)

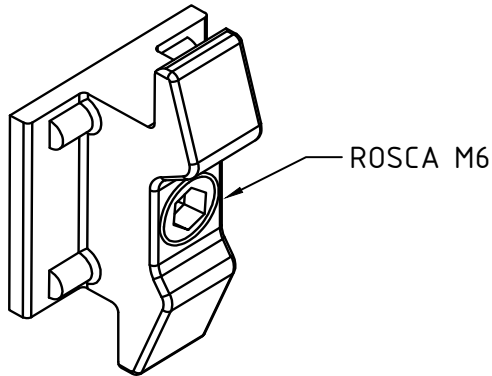

DIMENSÕES:
(escala 1:1)

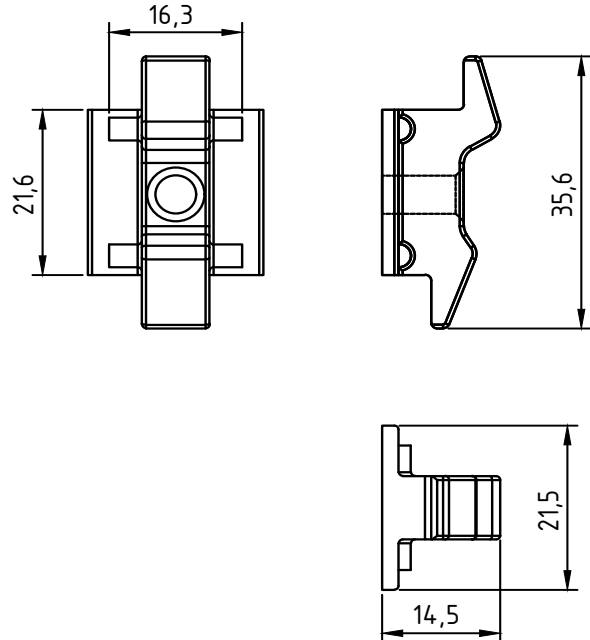

DETALHE DE APLICAÇÃO:
(escala 1:1)

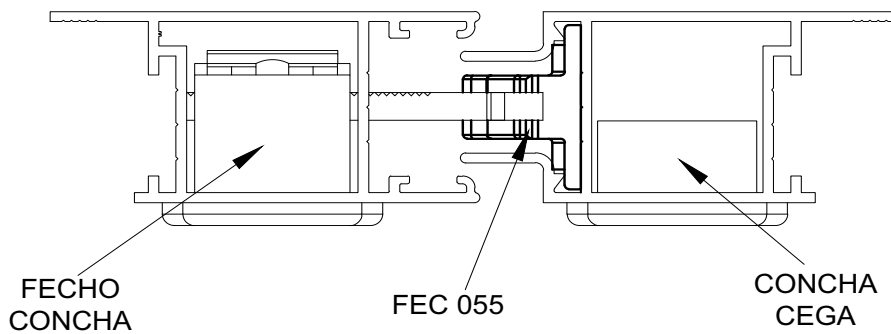

CARACTERÍSTICAS:

Componentes:	Matéria-prima:
Estrutura	POLIAMIDA FIBRA
Parafusos	Aço Inox

Utiliza 01 parafuso Aço Inox allen sem cabeça M6 x 8

Acabamentos	
Preto	Branco

Embalagem	100 Contra Fechos
	100 Parafusos

CÓDIGO	ACABAMENTO
FEC-055	Preto
FEC-055EB	Branco



JANELAS E PORTAS DE CORRER

Novembro/2008

CÓDIGO	DESCRIÇÃO
GUI - 01	Guia da Cinta em poliamida preto
GUI - 01EB	Guia da Cinta em poliamida branco

Usinagem
(S/ Escala)

Dimensões
(Escala 1:1,5)

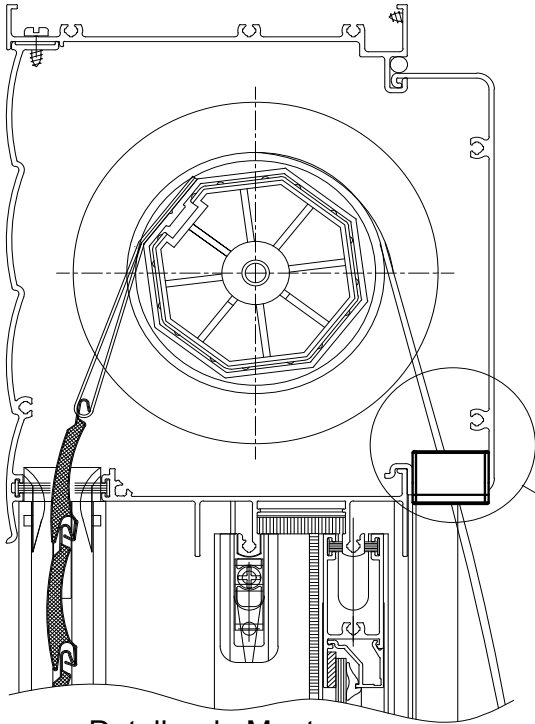

Detalhe de Montagem
(S/ Escala)

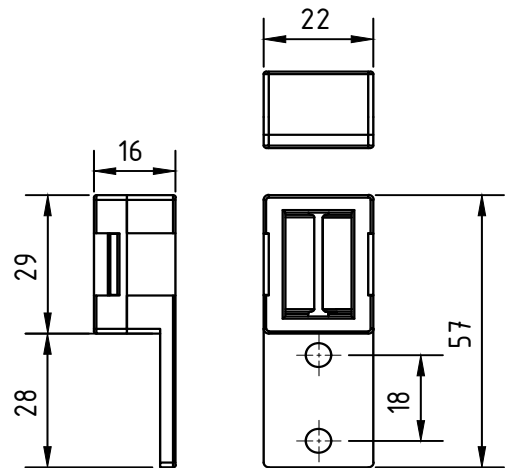
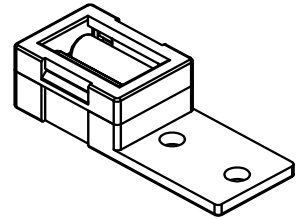
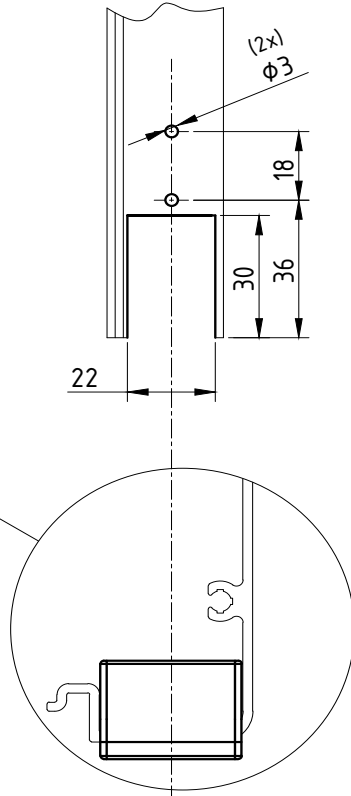

CÓDIGO	DESCRIÇÃO
GUI - 02	Guia da Cinta em poliamida preto
GUI - 02EB	Guia da Cinta em poliamida branco

Detalhe de Montagem
(S/ Escala)

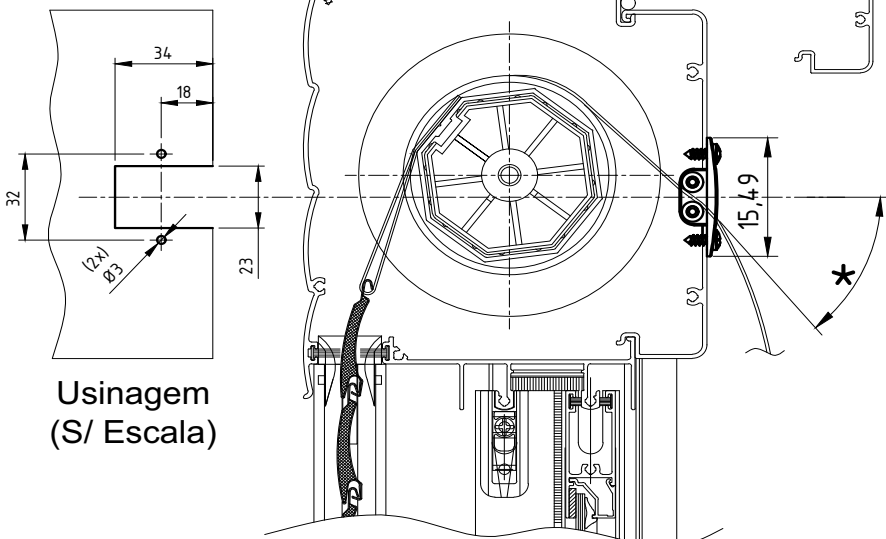

Usinagem
(S/ Escala)

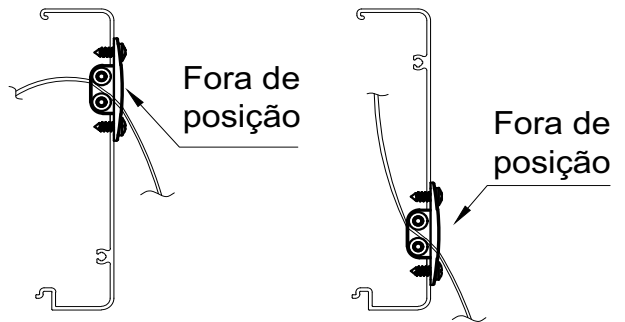

Dimensões
(Escala 1:2)

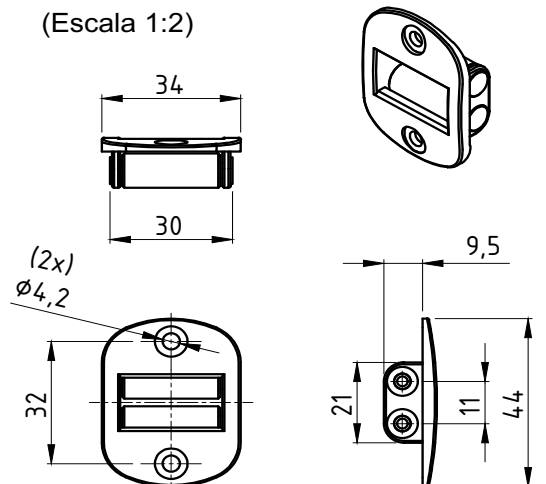

* OBS: ACONSELHAMOS MANTER UM ÂNGULO DE FIXAÇÃO CONFORME DETALHADO PARA NÃO PROVOCAR ESFORÇO EXCESSIVO NA GUIA DA CINTA.

DIMENSÕES:
(escala 1:1)

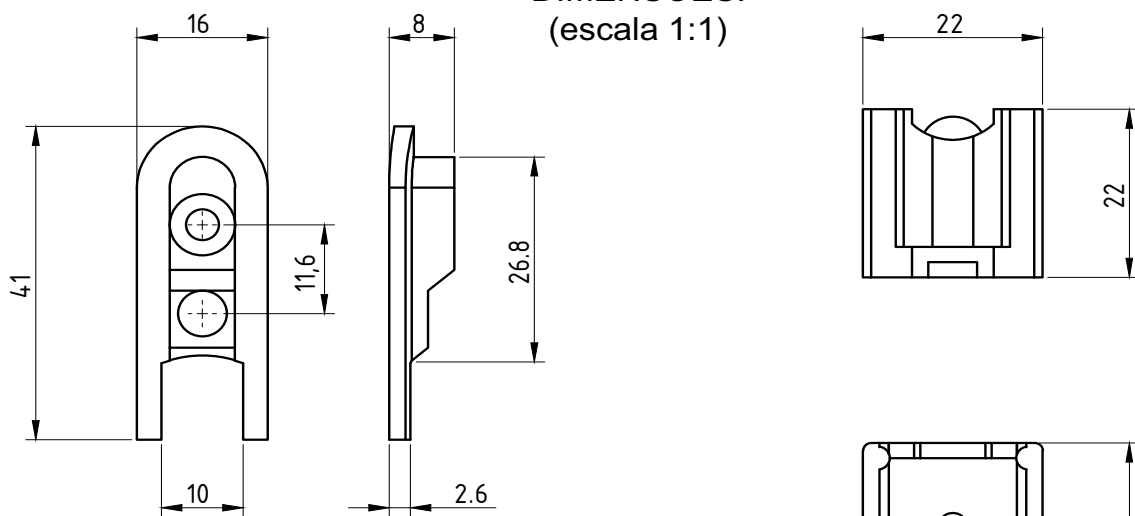

DETALHE DE MONTAGEM GUIA:
(sem escala)

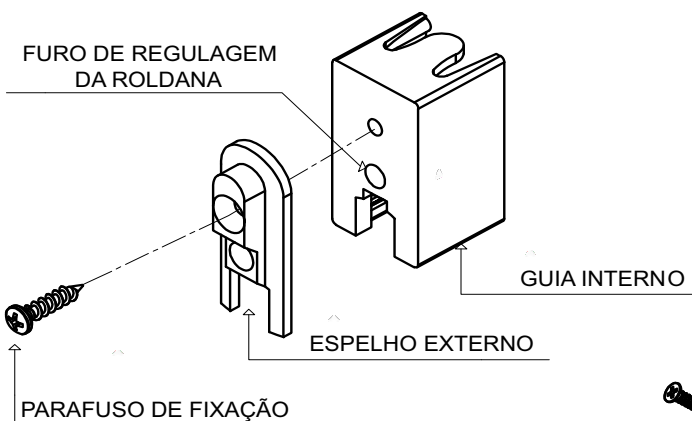

ESCOVA CIRCULAR

DETALHE DE APLICAÇÃO:
(sem escala)

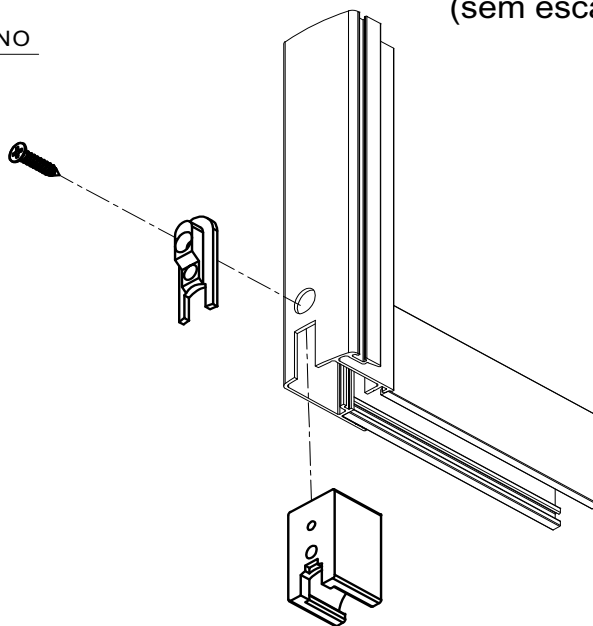

CARACTERÍSTICAS:

Componentes:	Matéria-prima:
Espelho externo	Poliamida
Guia interno	Poliamida
Parafuso	Aço Inox
Escova	Polipropileno

Acabamento	Preto
	Branco

Embalagem	10 Peças
-----------	----------

CÓDIGO	ACABAMENTO
GUI-250	Preto
GUI-250NB	Branco

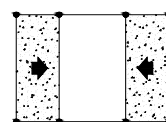

JANELAS
E PORTAS
DE CORRER

PERSPECTIVA (sem escala):

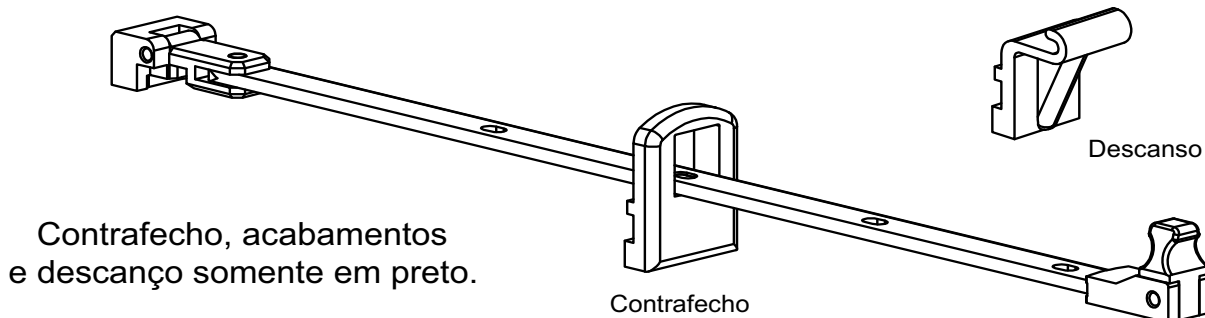

DIMENSÕES (sem escala):

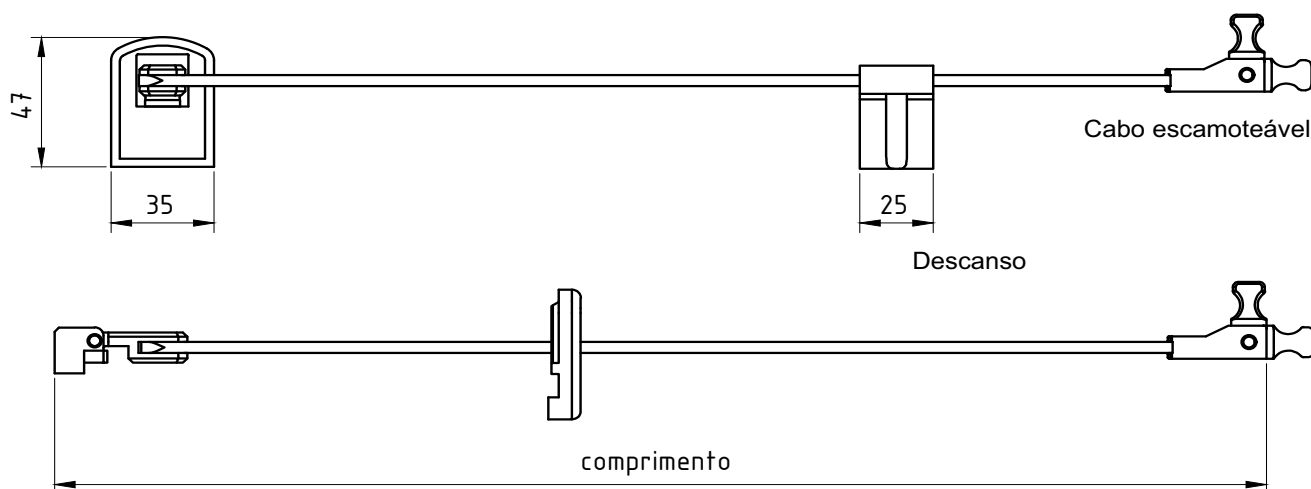

DETALHE DE APLICAÇÃO:
(escala 1:1)

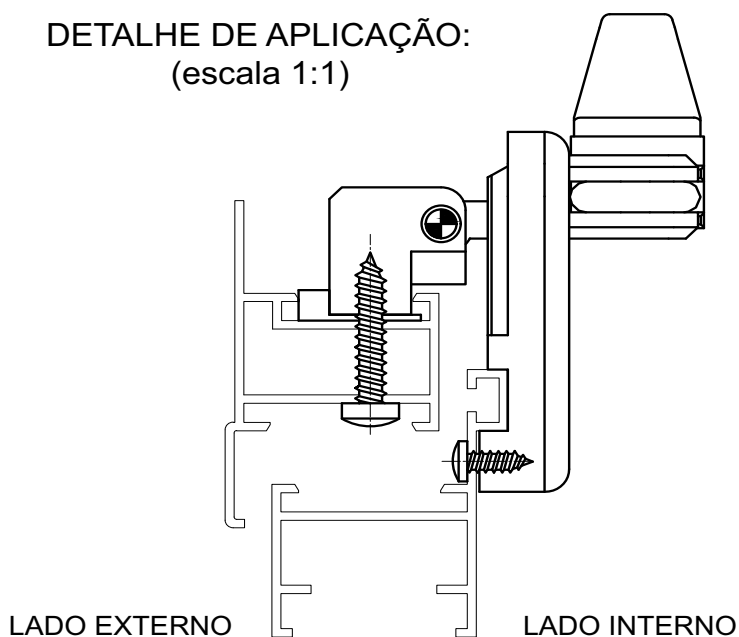

CARACTERÍSTICAS:

Componentes:	Matéria-prima:
Haste	Alumínio
Contrafecho	Poliamida
Acabamentos	Poliamida
Descanso	Poliamida
Parafusos	Aço Inox

Acabamento Anodizado e Pintado

Preto Fosco Branco

Embalagem

01 Haste
01 Descanso
01 Contrafecho
04 parafusos

Código Fosco	Código Preto	Código Branco	Comp. (mm)
HAS-059	HAS-060	HAS-060EB	200
HAS-061	HAS-062	HAS-062EB	250
HAS-063	HAS-064	HAS-064EB	300
HAS-065	HAS-066	HAS-066EB	400

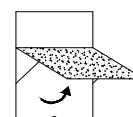

JANELAS
MAXIM-AR



LINGUETAS EM INOX

APLICAÇÃO:
ALUK 2.5®

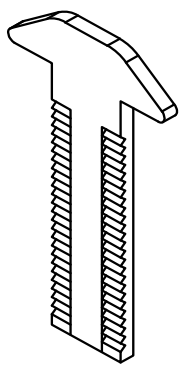

LIN-04

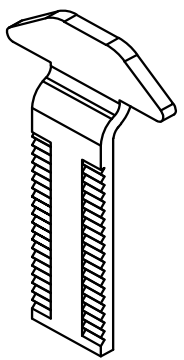

LIN-06

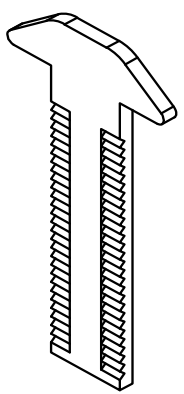

LIN-07

TORTA

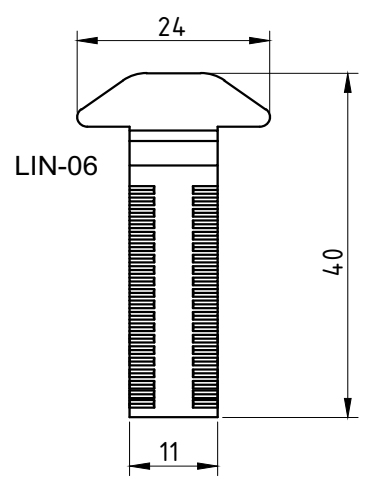

RETA

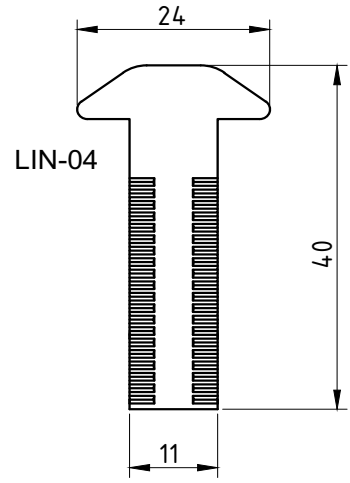

RETA

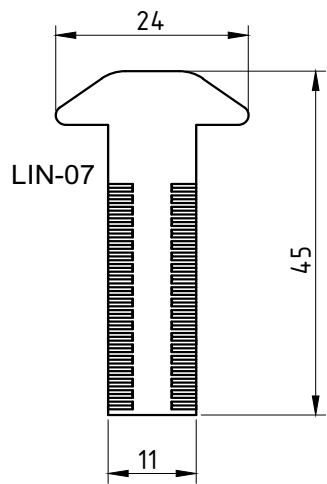

Embalagem 20 Linguetas

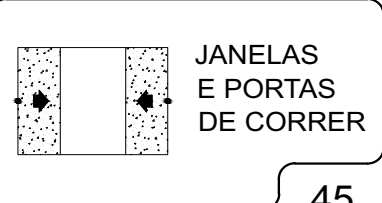

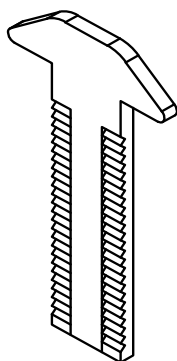

LIN-01

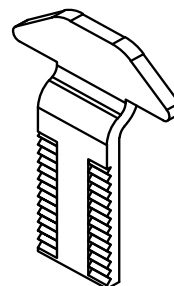

LIN-02

LIN-01

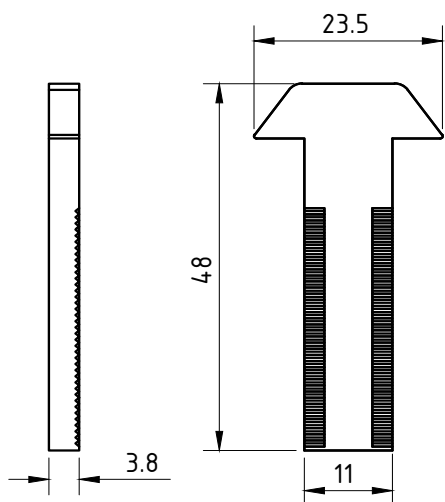

LIN-02

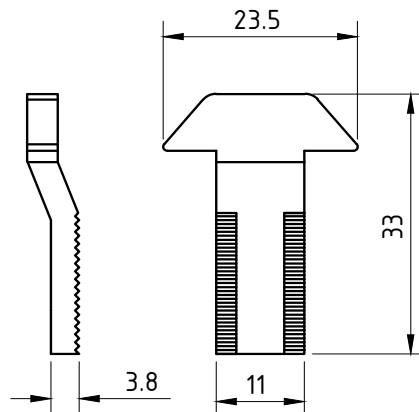

OBS: As linguetas LIN01 e LIN02 devem ser utilizadas somente com os fechos FEC-634, FEC634A, FEC-636, FEC636A, FEC-636EB e FEC-636AEB.

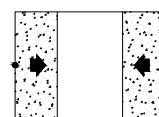

Outubro/2011

(escala 1:1)

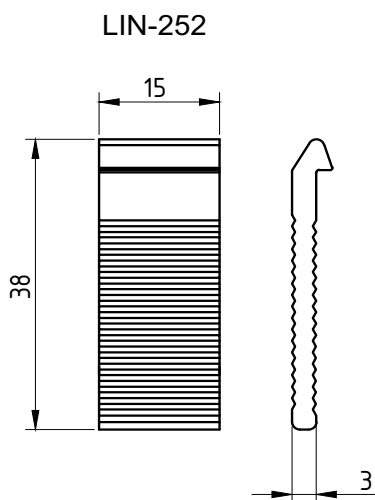
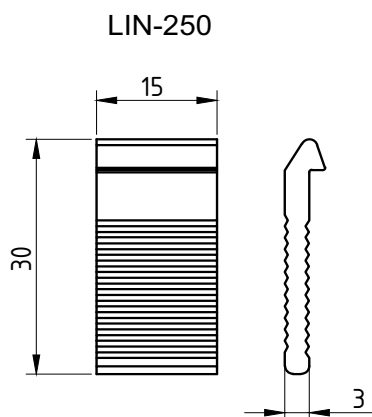

LIN-250/ LIN-252

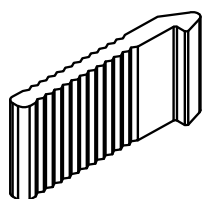
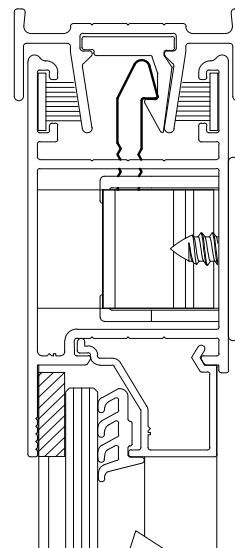

(escala 1:1)

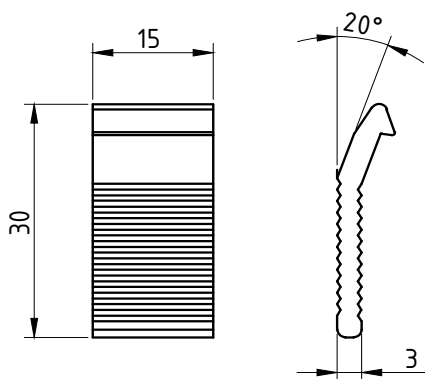

LIN-251

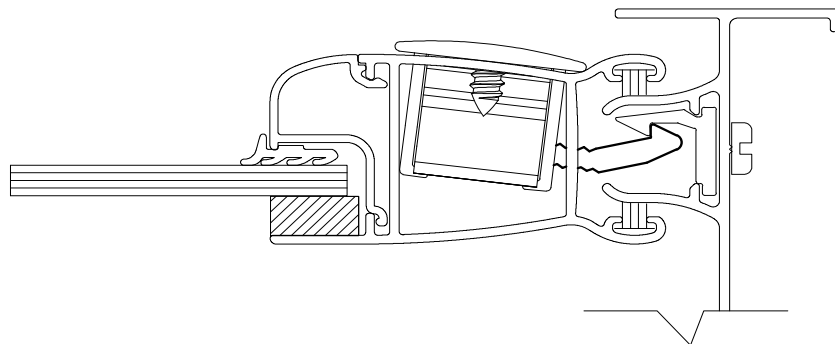
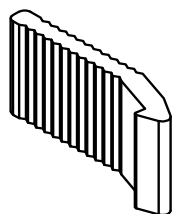

PARA O FEC-250

Componentes:

Matéria-prima:

Estrutura

Alumínio

Acabamento

Fosco

CÓDIGO

ACABAMENTO

LIN-250

Fosco

LIN-251

Fosco

LIN-252

Fosco

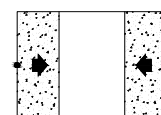

JANELAS
E PORTAS
DE CORRER

Embalagem

20 Linguetas



LIMITADOR DE ABERTURA

APLICAÇÃO:

ALUK 2.5®

PERSPECTIVA:
(sem escala)

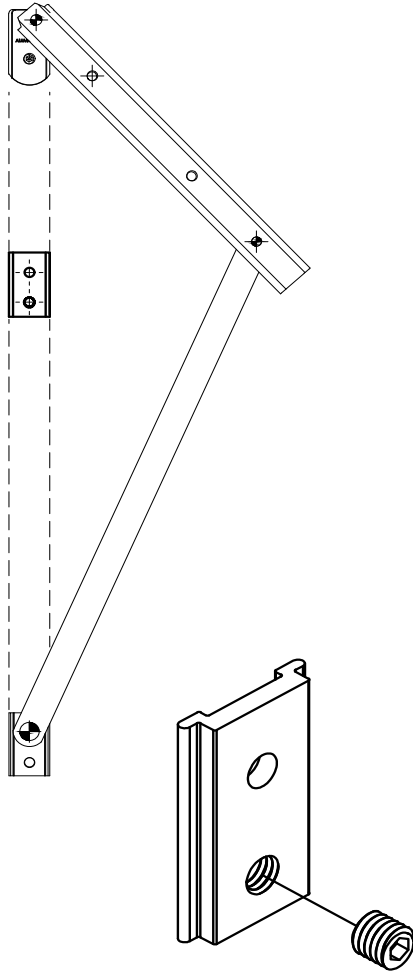

DIMENSÕES:
(escala 1:1)

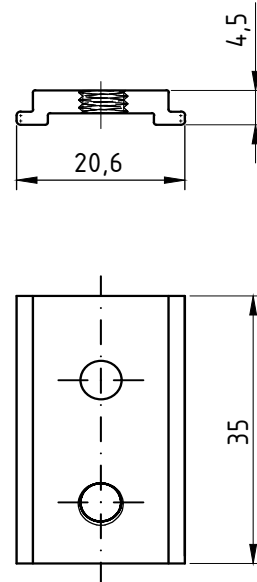

DETALHE DE APLICAÇÃO:
(Sem escala)

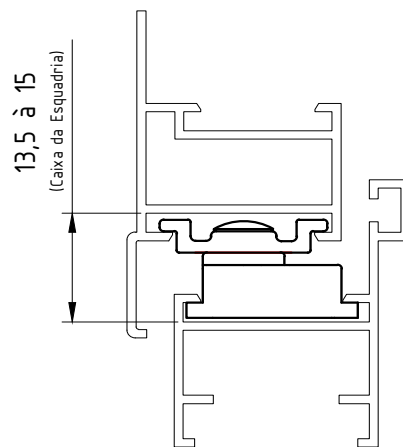

CARACTERÍSTICAS:

Componentes:	Matéria-prima:
Estrutura	Alumínio
Parafuso	Aço inox

Acabamento Anodizado e Pintado		
Preto	Fosco	Branco

Embalagem	20 Limitadores
	20 Parafusos

CÓDIGO	ACABAMENTO
LM-01	Preto
LM-010	Fosco
LM-01EB	Branco

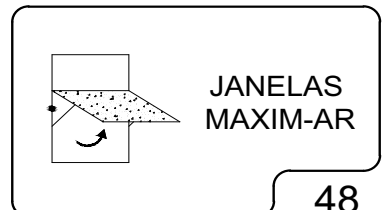



PRESILHA DO REMATE

BP-347 / MP-347 / N-1641 / 45-128

APLICAÇÃO:

ALUK 2.5®

DIMENSÕES:
(sem escala)

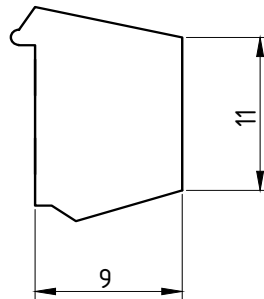
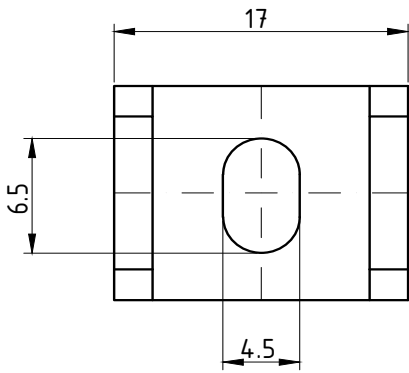

PERSPECTIVA:
(escala 1:1)

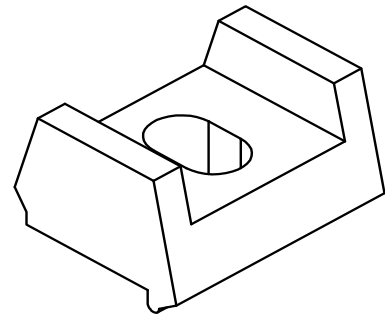

DETALHE DE APLICAÇÃO:
(sem escala)

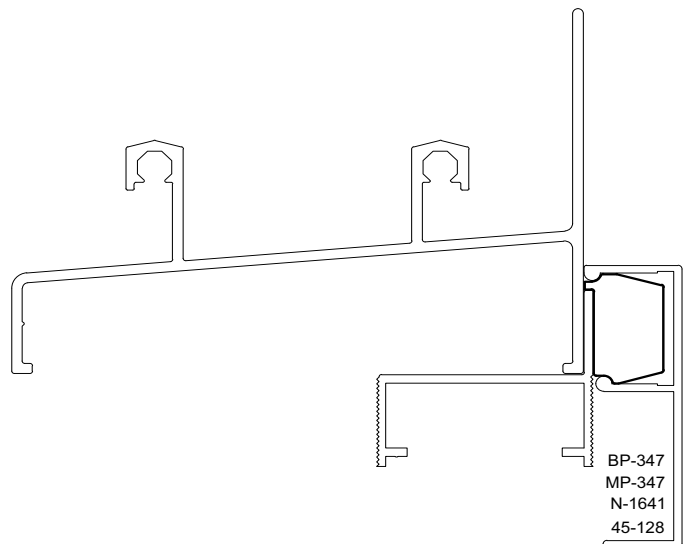

CARACTERÍSTICAS:

Componentes:

Matéria-prima:

Estrutura

Poliamida

Acabamento

Preto

Embalagem

200 Peças

CÓDIGO

ACABAMENTO

NYL- 190

Preto

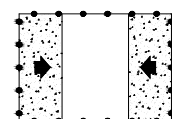

DIVERSAS



CAIXA DE DRENO E VEDADOR

APLICAÇÃO:

ALUK 2.5®

PERSPECTIVA:
(escala 1:1)

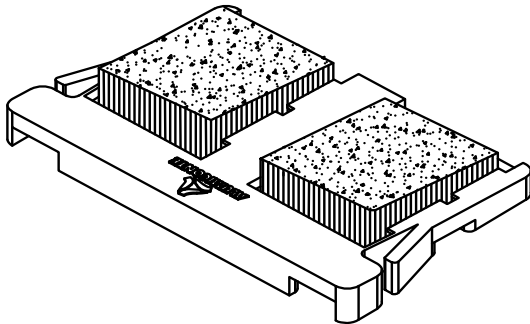

DIMENSÕES:
(escala 1:1)

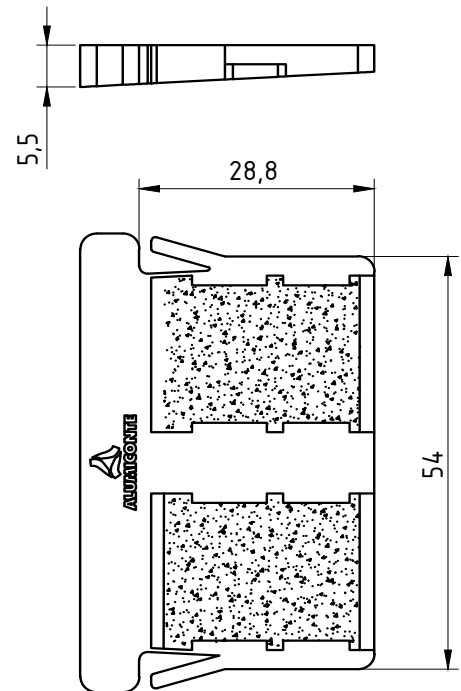

DETALHES DE APLICAÇÃO:
(sem escala)

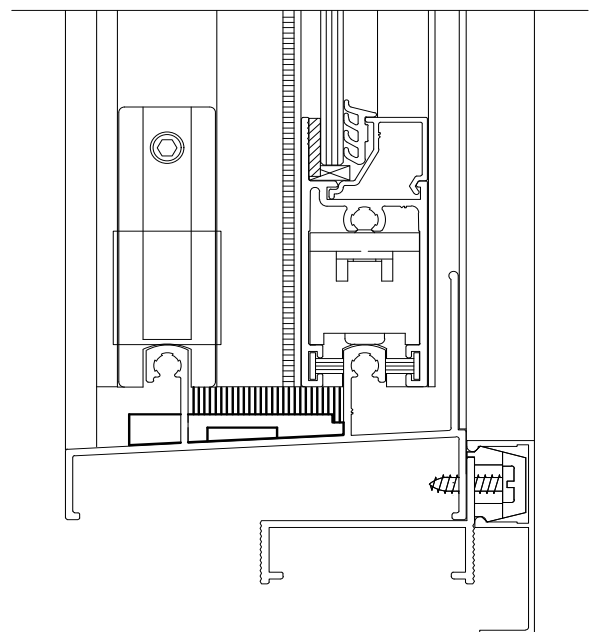
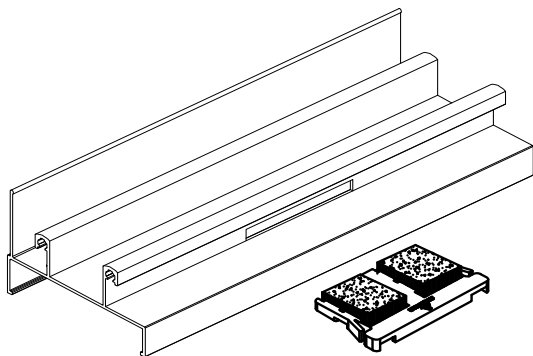

CARACTERÍSTICAS:

Componentes:	Matéria-prima:
Estrutura	Poliamida
Fita Vedadora	Polipropileno

Acabamento	Preto / Branco
------------	----------------

Embalagem	100 Peças
-----------	-----------

CÓDIGO	ACABAMENTO
NYL- 329	Preto
NYL- 329NB	Branco

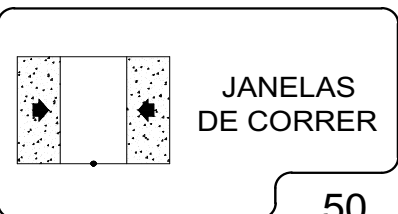

DIMENSÕES:
(escala 1:1)

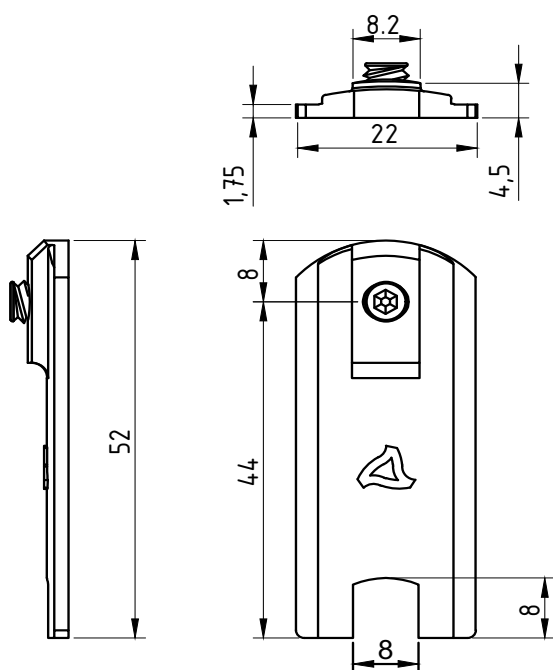

PERSPECTIVA:
(sem escala)

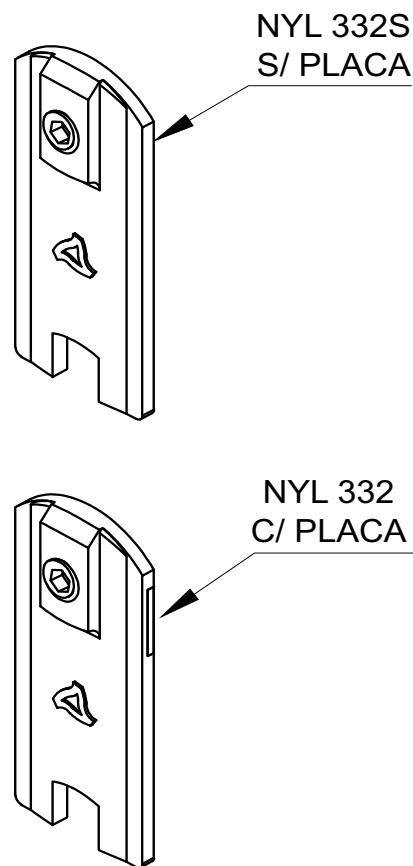

DETALHE DE APLICAÇÃO:
(sem escala)

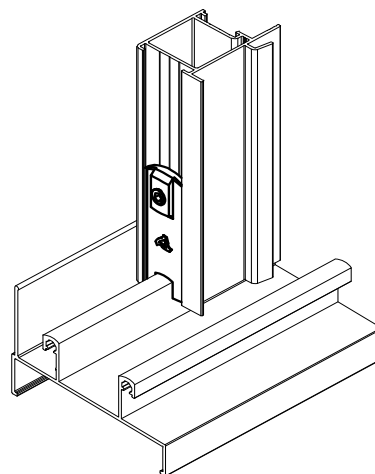

CARACTERÍSTICAS:

Componentes:	Matéria-prima:
Estrutura	Poliamida
Chapa de Reforço	Zamac
Parafusos	Aço Inox

Acabamento	Preto / Branco
------------	----------------

Embalagem	200 Guias
	200 Parafusos

CÓDIGO	ACABAMENTO
NYL-332S (S/ PLACA)	Preto
NYL-332SNB (S/ PLACA)	Branco
NYL-332 (C/ PLACA)	Preto
NYL-332NB (C/ PLACA)	Branco



PERSPECTIVA:
(escala 1,5:1)

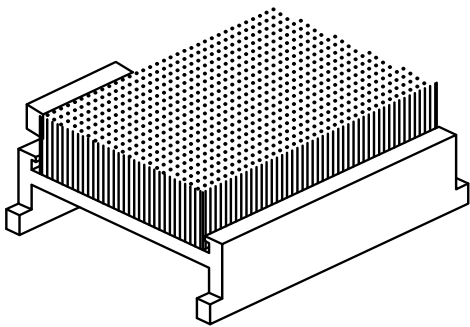

DIMENSÕES:
(escala 1:1)

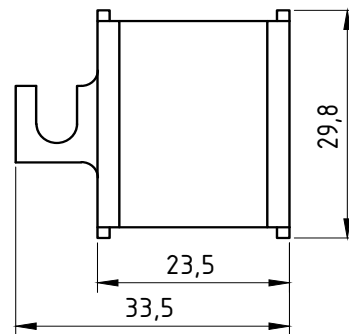
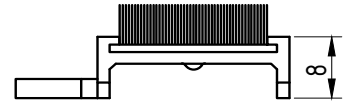

DETALHES DE APLICAÇÃO:
(sem escala)

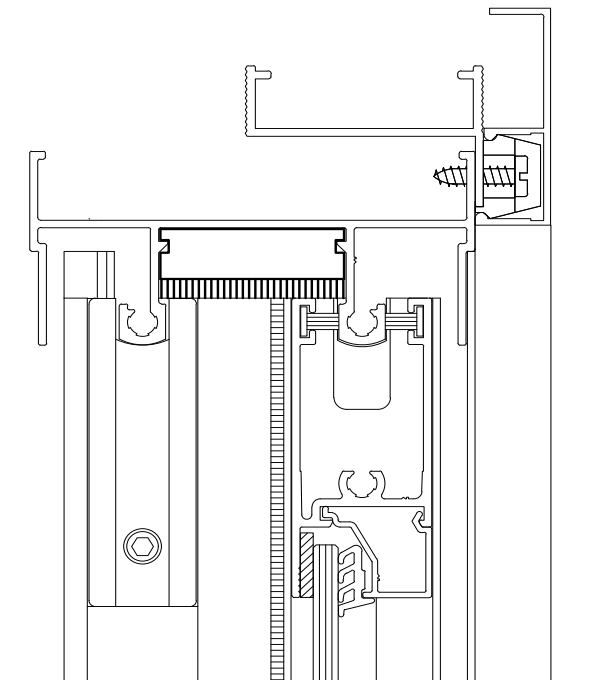
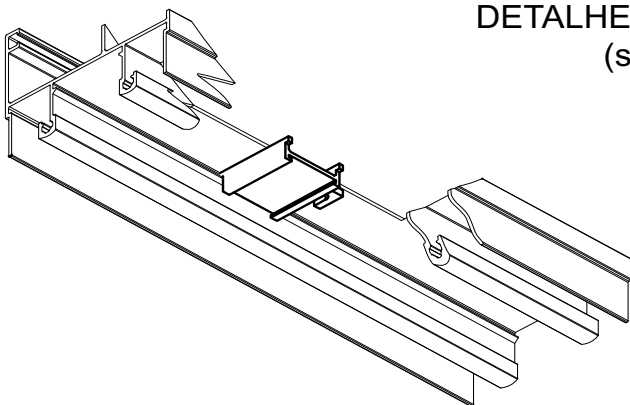

CARACTERÍSTICAS:

Componentes:	Matéria-prima:
Estrutura	Poliamida
Fita Vedadora	Polipropileno

Acabamento	Preto / Branco
------------	----------------

Embalagem	100 Peças
-----------	-----------

CÓDIGO	ACABAMENTO
NYL- 335	Preto
NYL- 335NB	Branco



JANELAS DE CORRER

Marco/2007

DIMENSÕES:
(escala 1:1)

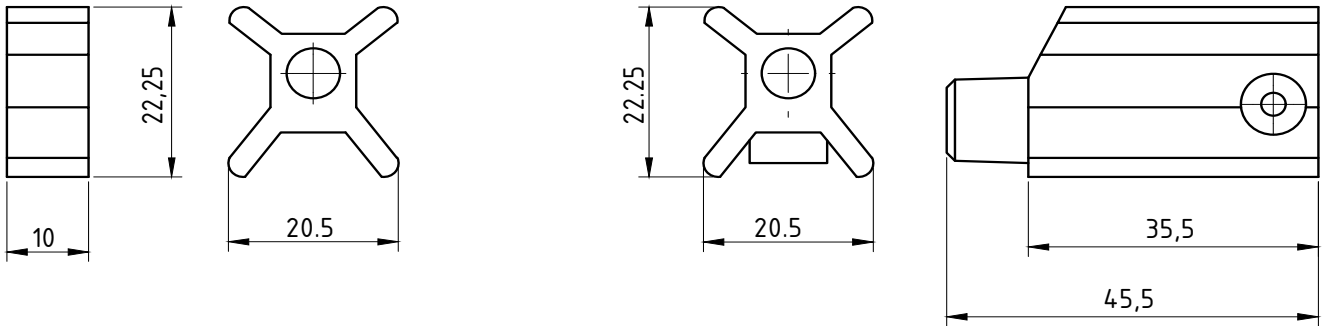

DETALHE DE APLICAÇÃO:
(sem escala)

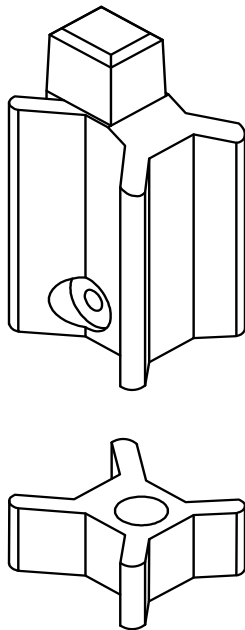

DETALHE DE APLICAÇÃO:
(sem escala)

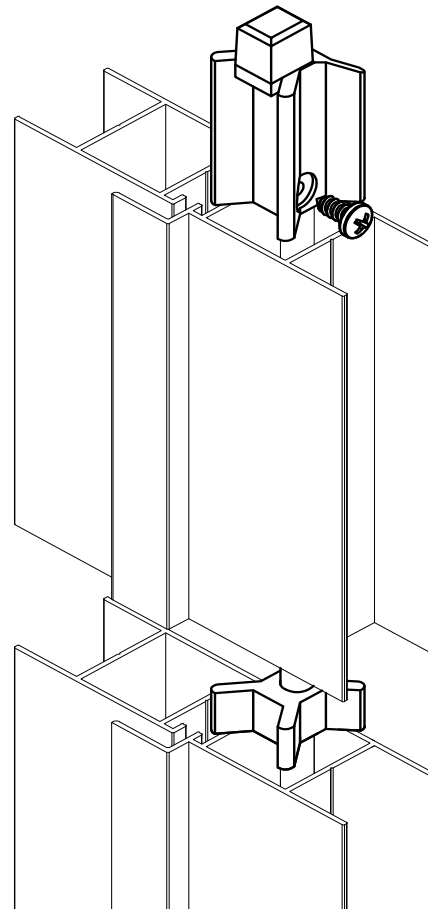

CARACTERÍSTICAS:

Componentes:	Matéria-prima:
Estrutura	Poliamida
Parafuso	Aço Inox

Acabamento
Preto

Embalagem	100 peças
-----------	-----------

CÓDIGO	ACABAMENTO
NYL-336	PRETO

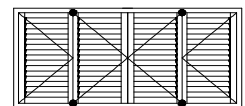

JANELAS CAMARÃO

PERSPECTIVA:
(escala 1:1)

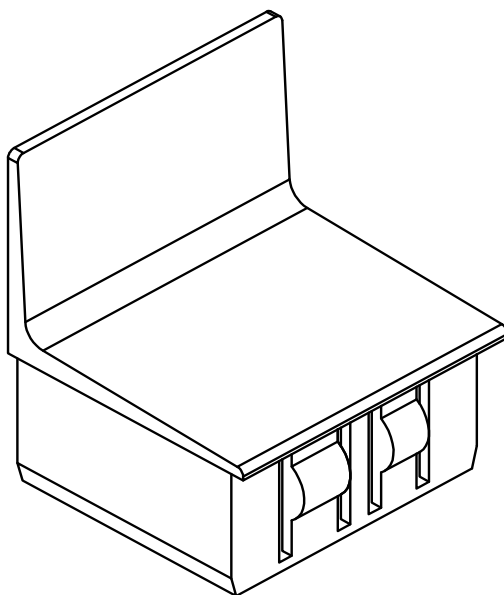

DIMENSÕES:
(escala 1:1)

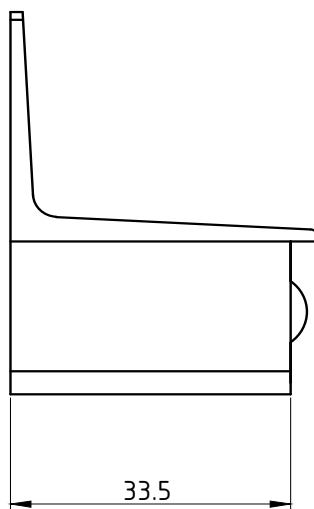
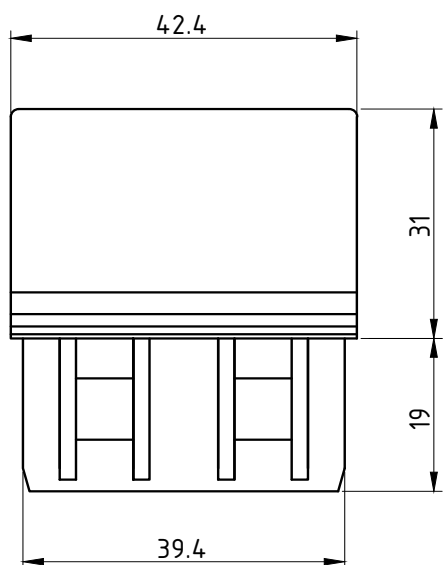

DETALHE DE APLICAÇÃO:
(sem escala)

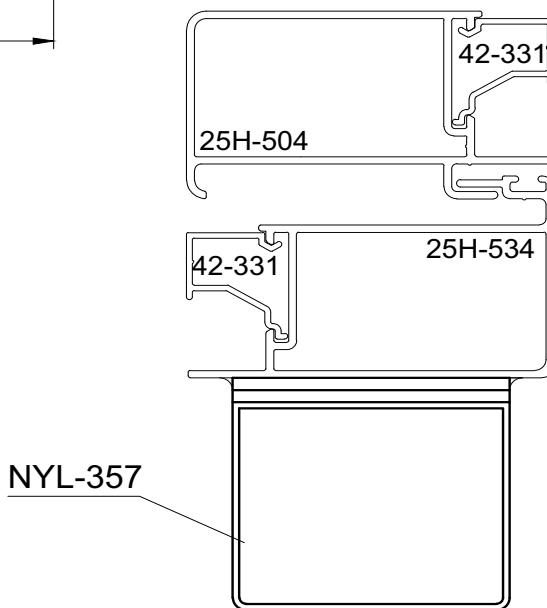

CARACTERÍSTICAS:

Componentes:

Matéria-prima:

Estrutura

Poliamida

Acabamento

Preto / Branco

Embalagem

20 Peças

CÓDIGO

ACABAMENTO

NYL- 357

Preto

NYL- 357NB

Branco

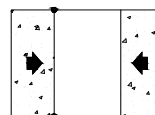

PORTAS
DE CORRER

DIMENSÕES:
(escala 1:1)

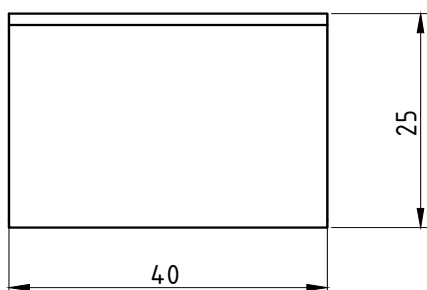
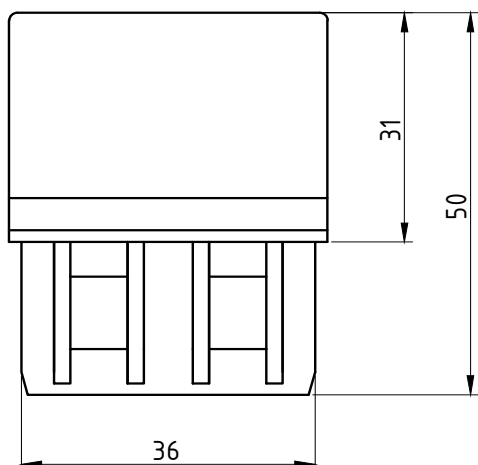

PERSPECTIVA:
(escala 1:1)

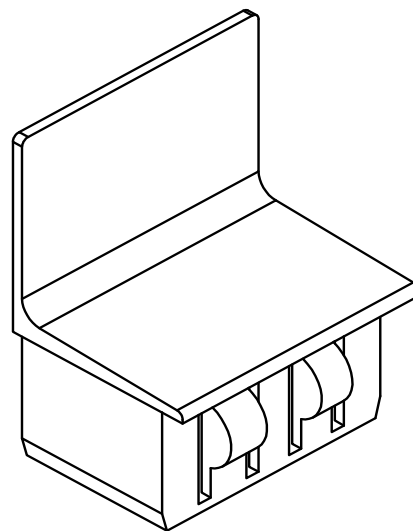

DETALHE DE APLICAÇÃO:
(sem escala)

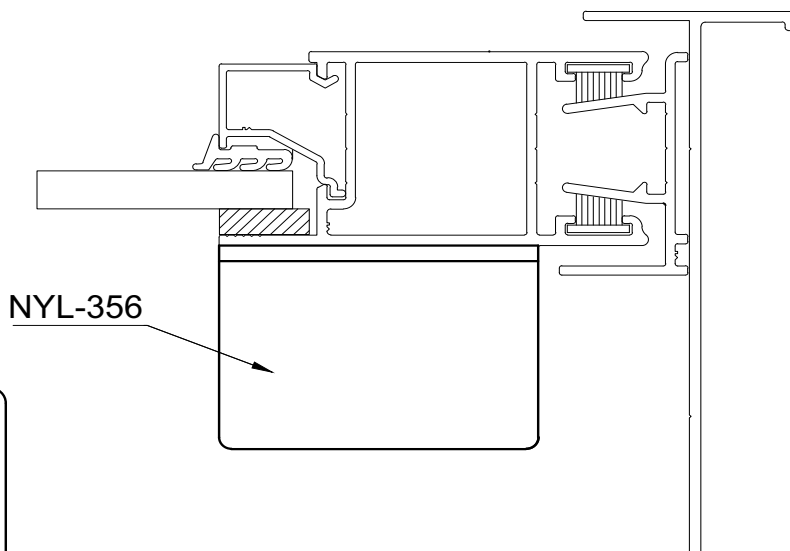

CARACTERÍSTICAS:

Componentes:

Estrutura

Matéria-prima:

Poliamida

Acabamento

Preto / Branco

Embalagem

20 Peças

CÓDIGO

ACABAMENTO

NYL- 356

Preto

NYL- 356NB

Branco

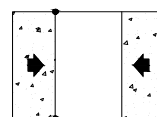

PORTAS
DE CORRER

DIMENSÕES:
(escala 1:1)

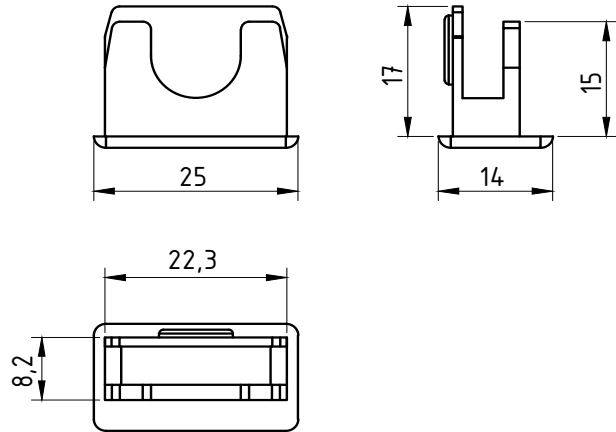

PERSPECTIVA:
(escala 2:1)

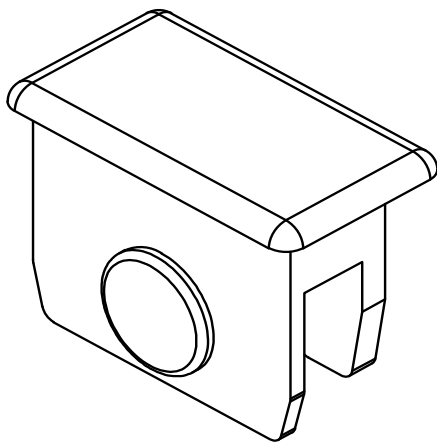

DETALHE DE APLICAÇÃO:
(sem escala)

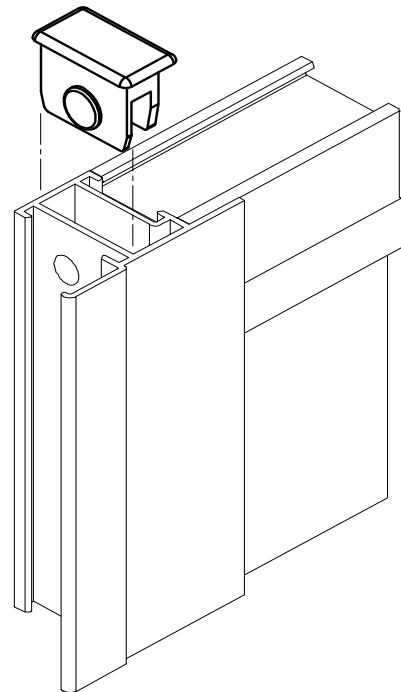

CARACTERÍSTICAS:

Componentes:	Matéria-prima:
Estrutura	Poliamida

Acabamentos	
Preto	Branco

Embalagem	100 peças
-----------	-----------

CÓDIGO	ACABAMENTO
NYL-355	Preto
NYL-355NB	Branco

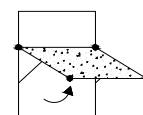

JANELAS
MAXIM-AR

Junho/2012

PERSPECTIVA:
(escala 1:1)

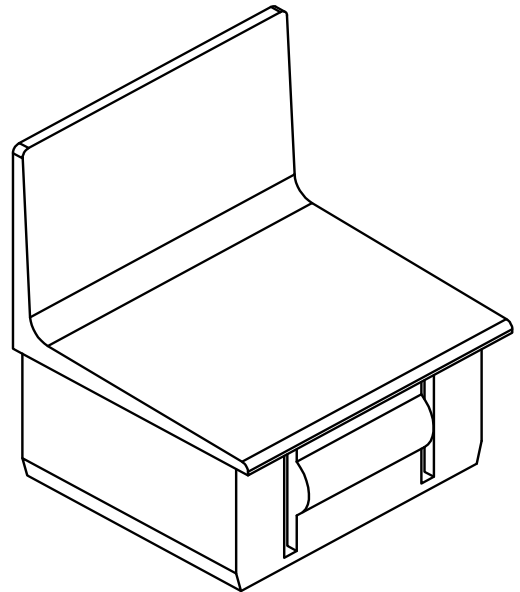

DIMENSÕES:
(escala 1:1)

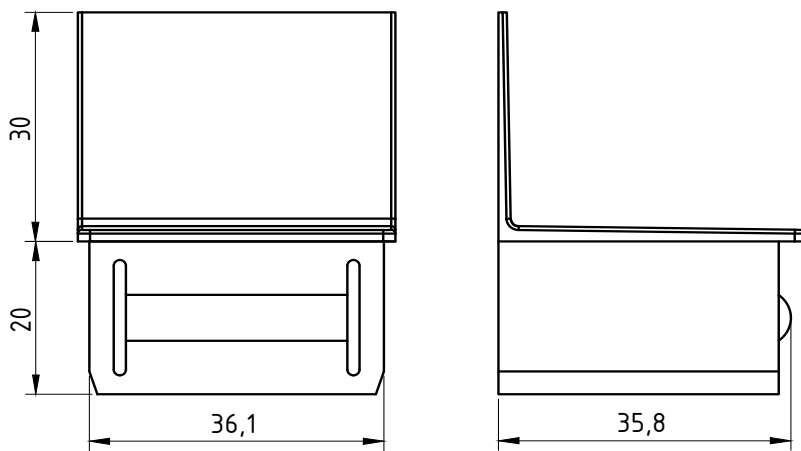

DETALHE DE APLICAÇÃO:
(sem escala)

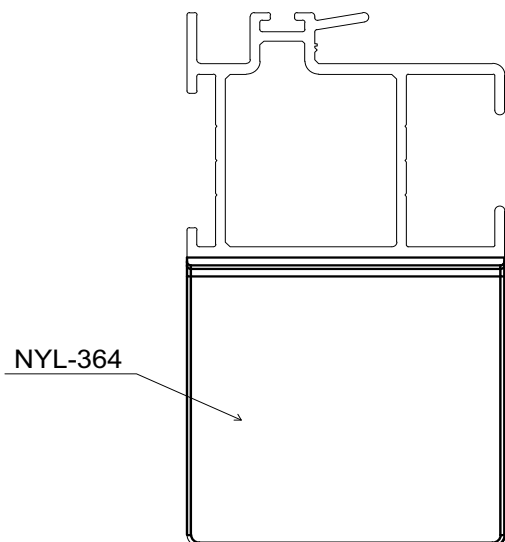

CARACTERÍSTICAS:

Componentes:	Matéria-prima:
Estrutura	Poliamida

Acabamento	Preto/ Branco
------------	---------------

Embalagem	20 Peças
-----------	----------

CÓDIGO	ACABAMENTO
NYL - 364	Preto
NYL - 364NB	Branco

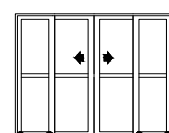

Portas de
Correr

Maio/2011

DIMENSÕES:
(escala 1:1)

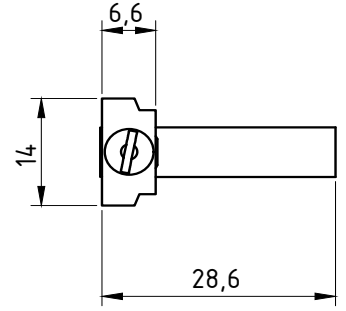
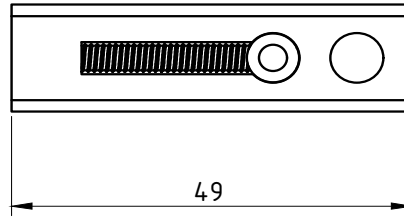
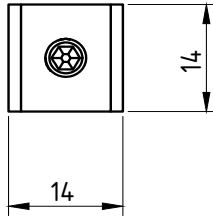
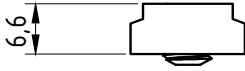

DETALHE DE APLICAÇÃO:
(sem escala)

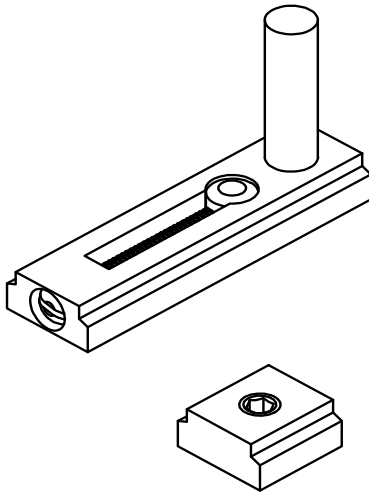

DETALHE DE APLICAÇÃO:
(sem escala)

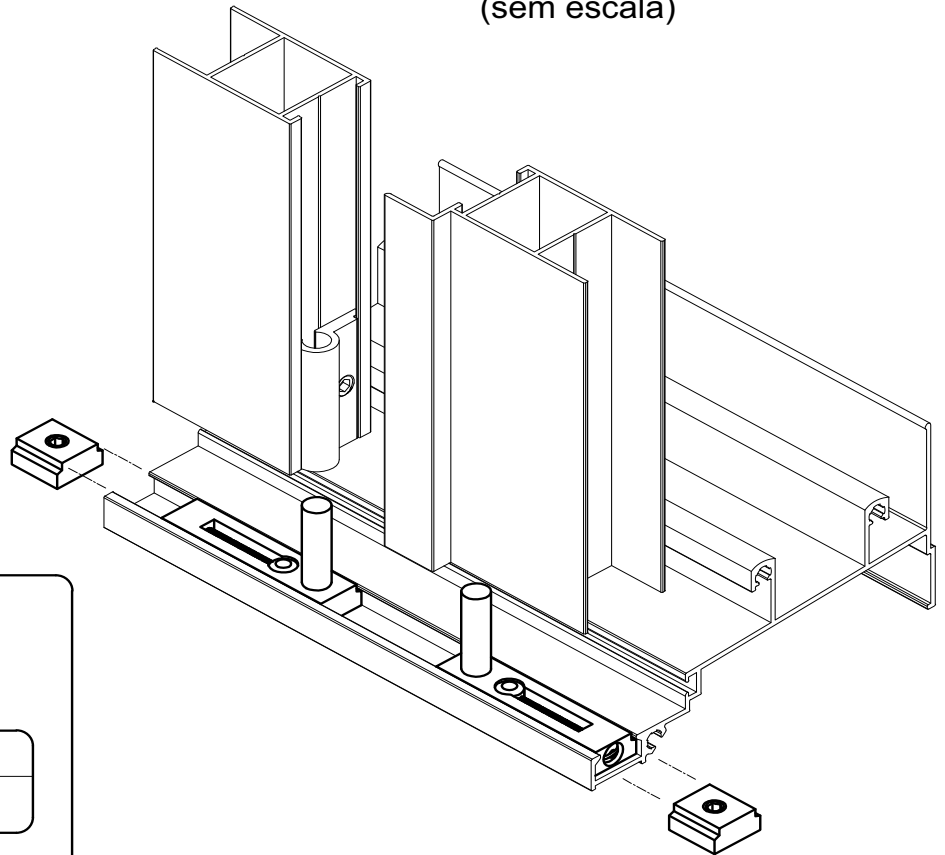

CARACTERÍSTICAS:

Componentes:	Matéria-prima:
Estrutura	Alumínio/Aço

Acabamentos

Preto

Embalagem

100 peças

CÓDIGO	ACABAMENTO
NYL-362	PRETO

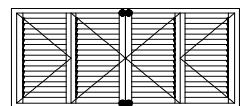

JANELAS CAMARÃO

DIMENSÕES:
(escala 1:1)

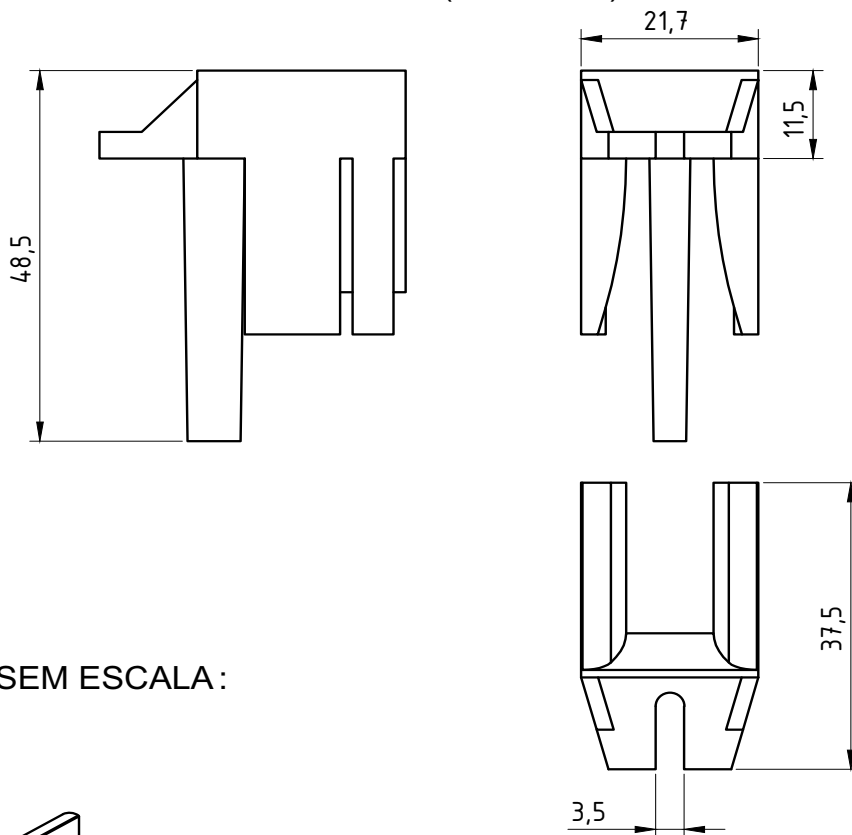

PERSPECTIVA SEM ESCALA:

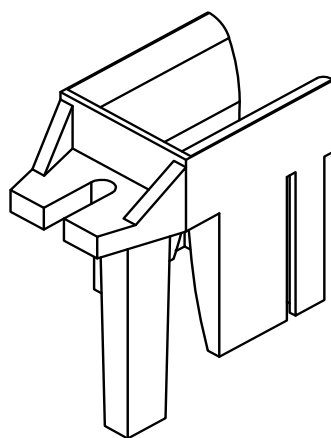

DETALHE DE APLICAÇÃO:
(sem escala)

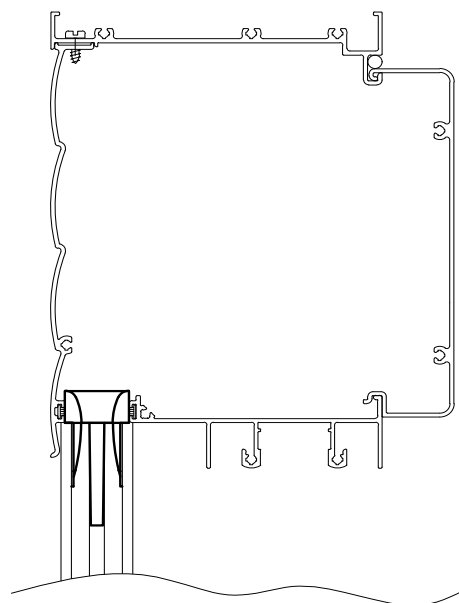

CARACTERÍSTICAS:

Componentes:	Matéria-prima:
Estrutura	Poliamida
Parafuso	Aço Inox

Acabamento	Preto
-------------------	--------------

Embalagem	25 Peças
	25 Parafusos

CÓDIGO	ACABAMENTO
NYL-370	Preto

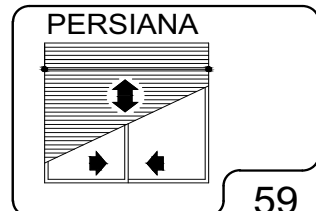

DIMENSÕES:
(escala 1:1)

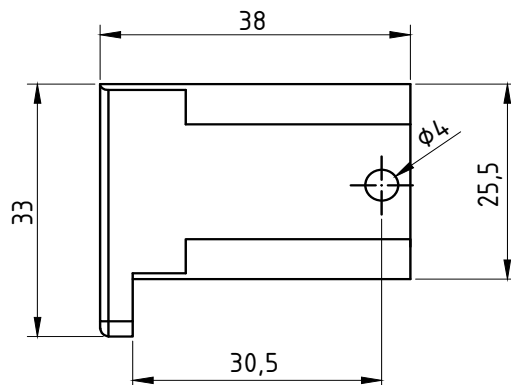
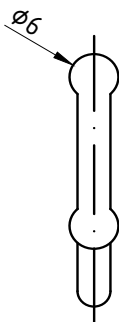
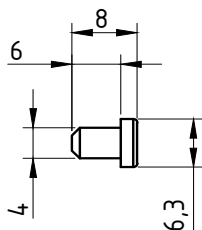

PERSPECTIVA SEM ESCALA:

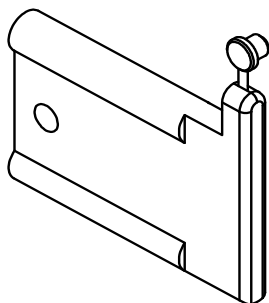

DETALHE DE APLICAÇÃO:
(sem escala)

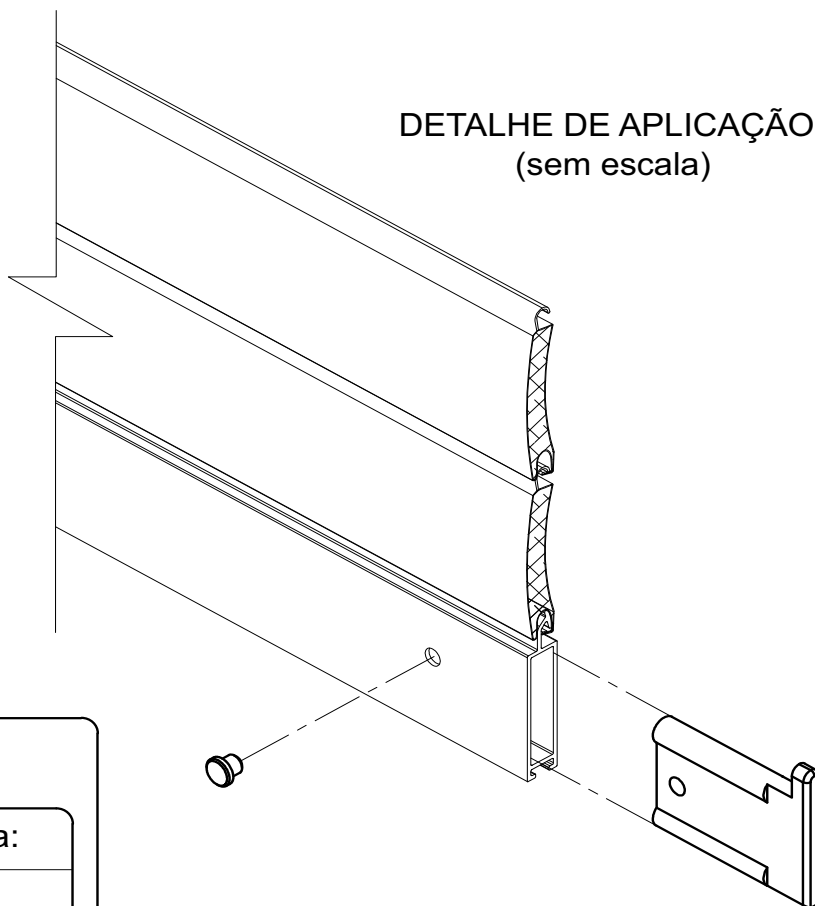

CARACTERÍSTICAS:

Componentes:	Matéria-prima:
Estrutura	Poliamida
Pino	Poliamida

Acabamento	Preto
------------	-------

Embalagem	25 Peças
-----------	----------

CÓDIGO	ACABAMENTO
NYL-369	Preto

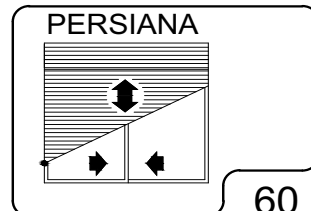

DIMENSÕES:
(escala 1:2)

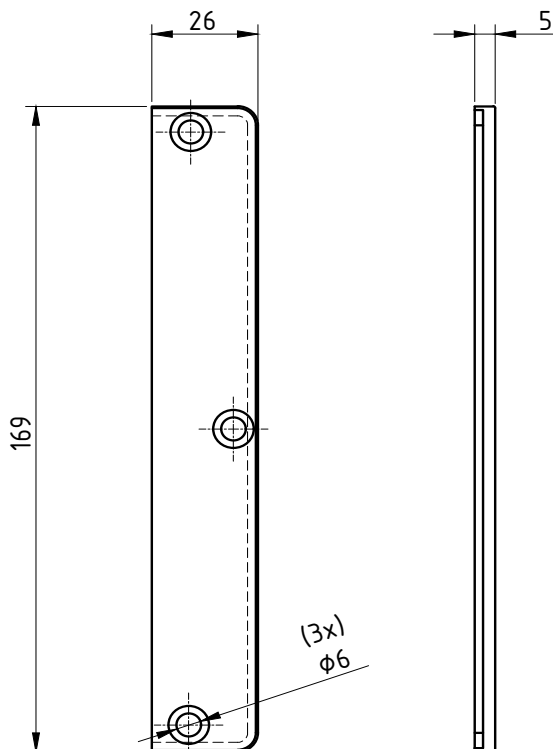

PERSPECTIVA:
(escala 1:2)

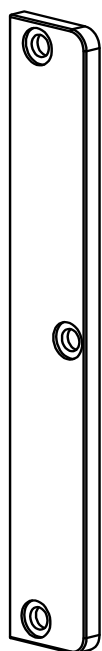

DETALHE DE APLICAÇÃO:
(sem escala)

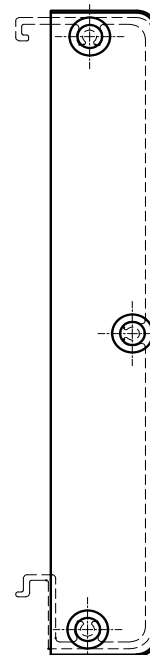

CARACTERÍSTICAS:

Componentes:	Matéria-prima:
Estrutura	Poliamida
Parafusos	Aço Inox

Acabamentos	
Preto	Branco

Embalagem	20 Peças
	60 Parafusos

CÓDIGO	ACABAMENTO
NYL- 382	Preto
NYL- 382NB	Branco

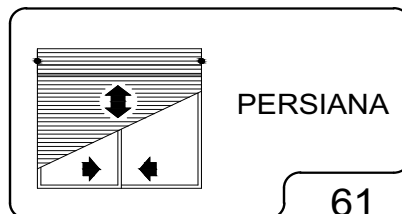



**TAMPA LATERAL DA
PORTA COM PERSIANA**
MN-0032, MG-068, ALG-230

APLICAÇÃO:

ALUK 2.5®

Novembro/2008

DIMENSÕES:
(escala 1:2)

PERSPECTIVA:
(escala 1:2)

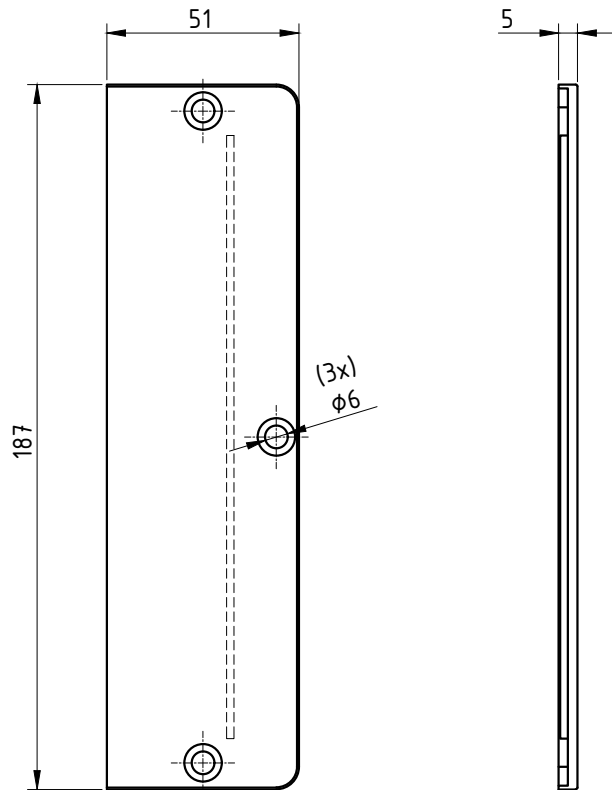
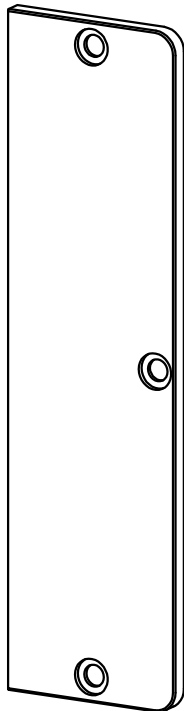

DETALHE DE APLICAÇÃO:
(sem escala)

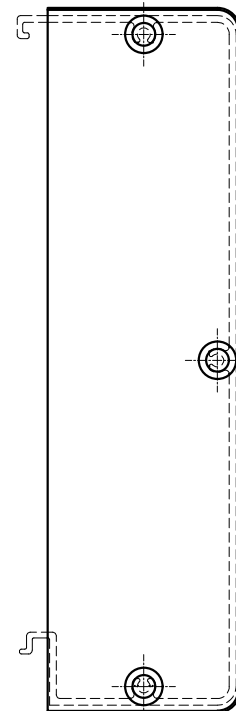

CARACTERÍSTICAS:

Componentes:	Matéria-prima:
Estrutura	Poliamida
Parafusos	Aço Inox

Acabamentos	
Preto	Branco

Embalagem	20 Peças
	60 Parafusos

CÓDIGO	ACABAMENTO
NYL- 383	Preto
NYL- 383NB	Branco

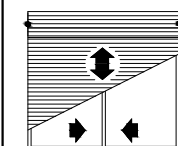

PERSIANA

DIMENSÕES:
(escala 1:1)

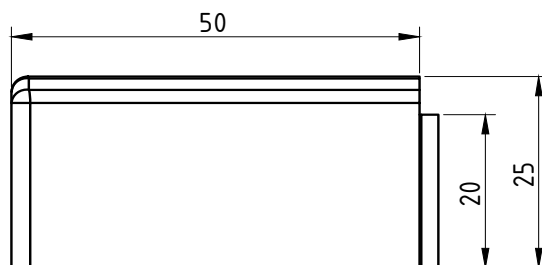

PERSPECTIVA:
(escala 1:1)

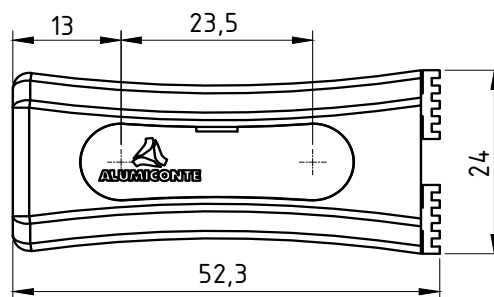
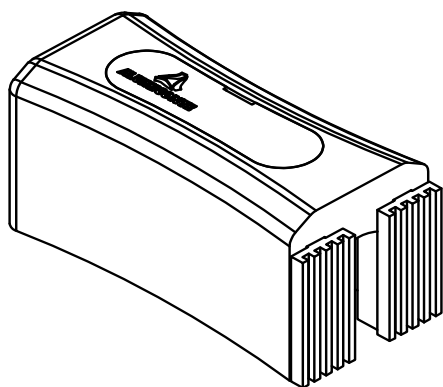

DETALHE DE APLICAÇÃO:
(sem escala)

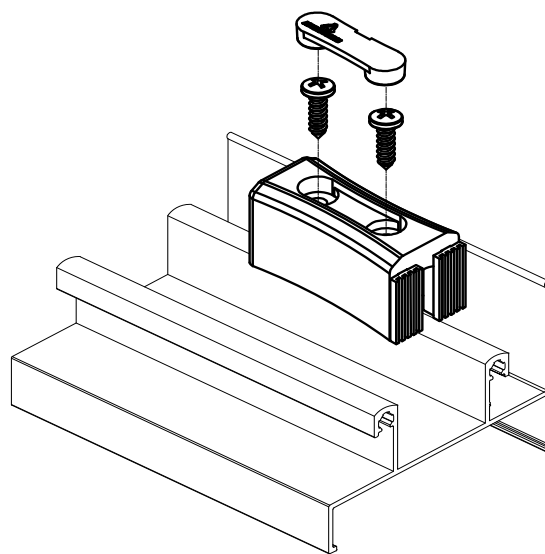

CARACTERÍSTICAS:

Componentes:	Matéria-prima:
Estrutura	Poliamida
Guarnição	EPDM
Parafusos	Aço Inox

Acabamentos

Preto

Branco

Embalagem

20 peças

CÓDIGO	ACABAMENTO
NYL- 414	Preto
NYL- 414NB	Branco

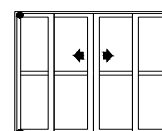

JANELAS
E PORTAS
DE CORRER

DIMENSÕES:
(escala 1:1)

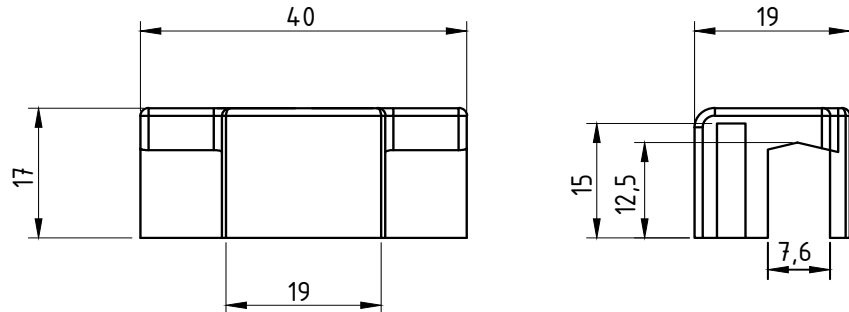

PERSPECTIVA SEM ESCALA:

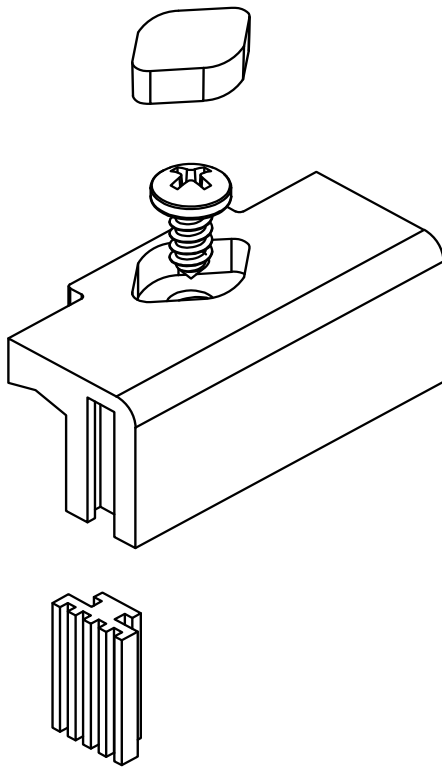

DETALHE DE APLICAÇÃO:
(sem escala)

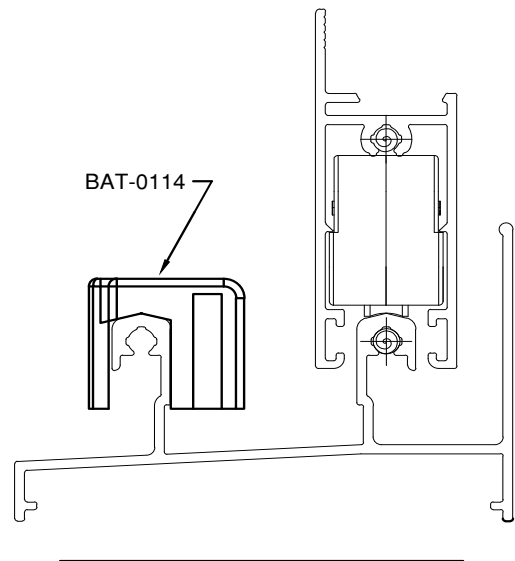

CARACTERÍSTICAS:

Componentes:	Matéria-prima:
Estrutura	Poliamida
Guarnição	EPDM(PRETO)
Parafusos	Inox

Acabamento	Preto
	Branco

Embalagem	10 Peças
-----------	----------

CÓDIGO	ACABAMENTO
BAT-0414-PR	Preto
BAT-0414-BC	Branco

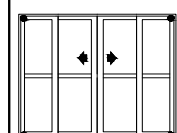

JANELAS
E PORTAS
DE CORRER

Marca/2006

PERSPECTIVA:

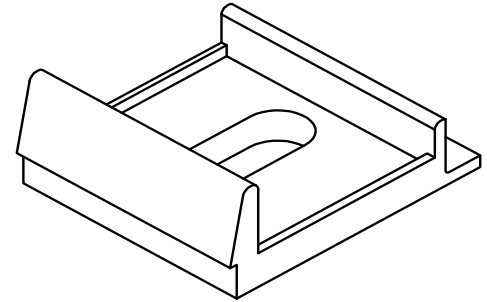

DIMENSÕES:
(escala 2:1)

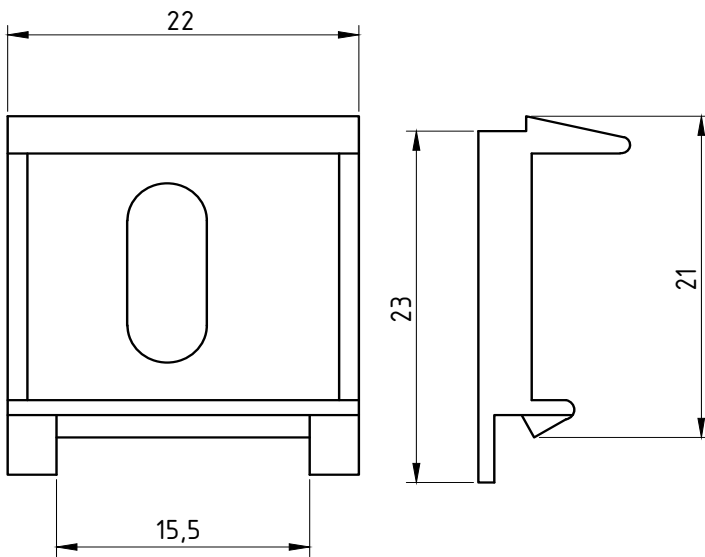

DETALHE DE APLICAÇÃO:
(sem escala)

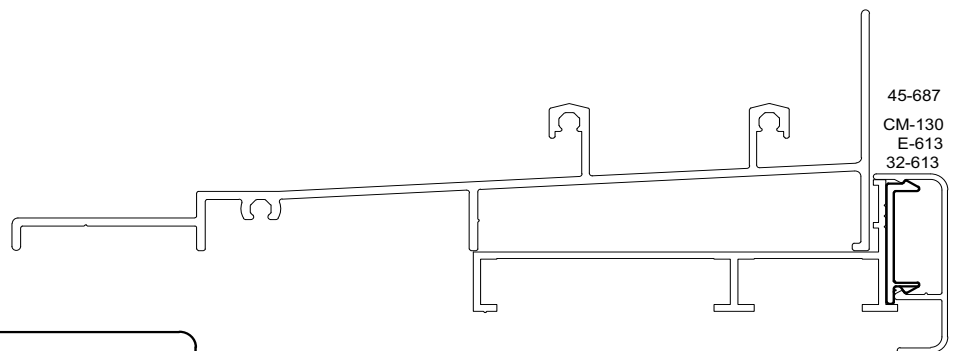

45-687
CM-130
E-613
32-613

CARACTERÍSTICAS:

Componentes:

Matéria-prima:

Estrutura

Poliamida

Acabamento

Cinza

Embalagem

200 Peças

CÓDIGO

ACABAMENTO

PRE-965

Cinza

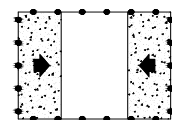

DIVERSAS



RECOBRIMENTO DA SOLEIRA CM-169

APLICAÇÃO:

ALUK 2.5®

Junho/2012

DIMENSÕES:
(escala 1:1)

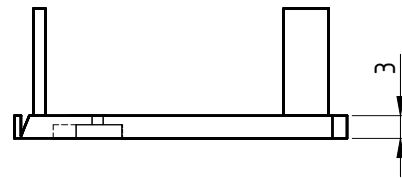
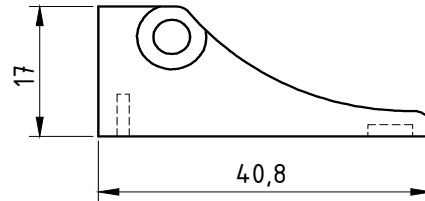

PERSPECTIVA:
(sem escala)

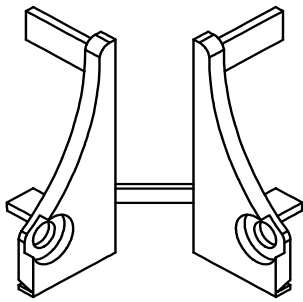

DETALHE DE APLICAÇÃO:
(sem escala)

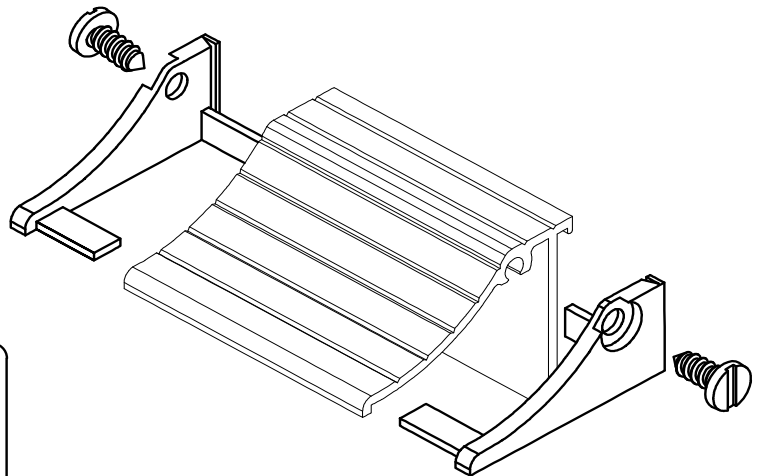

CARACTERÍSTICAS:

Componentes:	Matéria-prima:
Estrutura	Poliamida
Parafuso	Aço Inox

Acabamento	Preto / Branco
------------	----------------

Embalagem	10 Pares
-----------	----------

CÓDIGO	ACABAMENTO
NYL- 416	Preto
NYL- 416NB	Branco

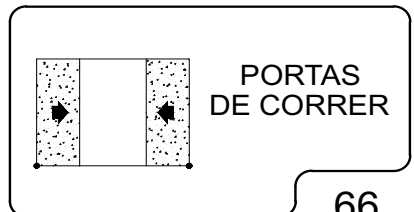

PORTAS
DE CORRER

DIMENSÕES:
(escala 1:1)

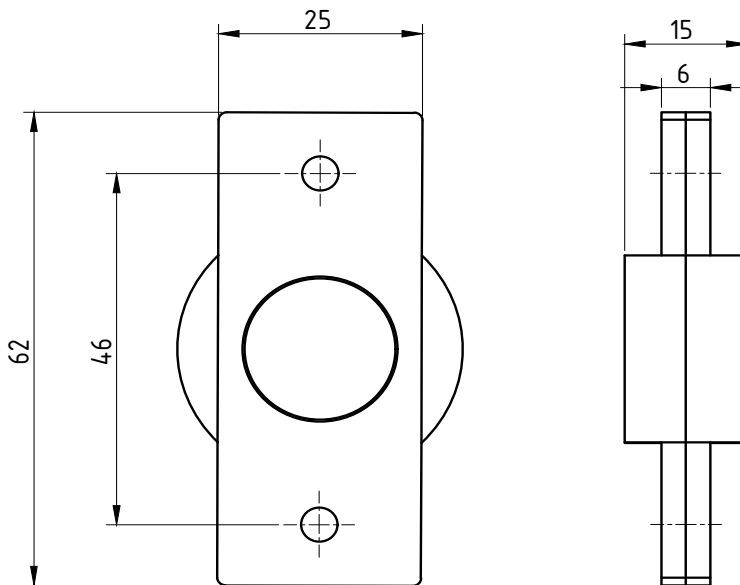

DETALHE DE APLICAÇÃO:
(sem escala)

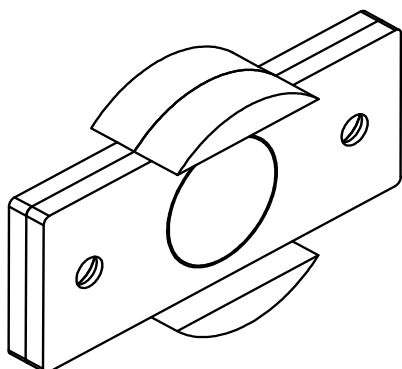

DETALHE DE APLICAÇÃO:
(sem escala)

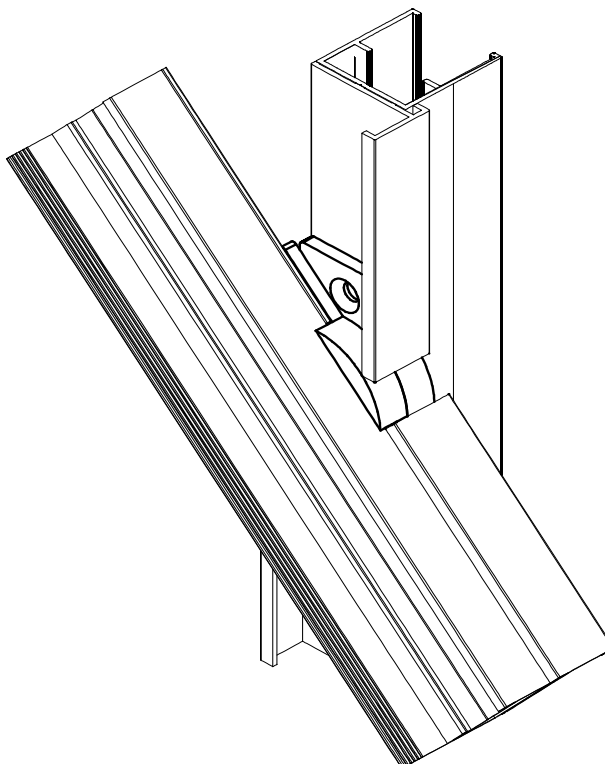

CARACTERÍSTICAS:

Componentes:	Matéria-prima:
Estrutura	Poliamida
Parafuso	Aço Inox

Acabamento

Preto

Branco

Embalagem

100 peças

CÓDIGO	ACABAMENTO
PIV-753	PRETO
PIV-753NB	BRANCO

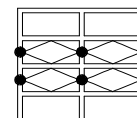

JANELAS
BASCULANTES

Janeiro/2008

PERSPECTIVA:
(sem escala)

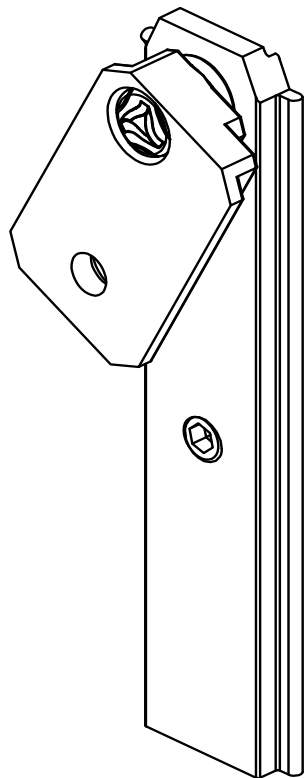

DIMENSÕES:
(escala 1:1)

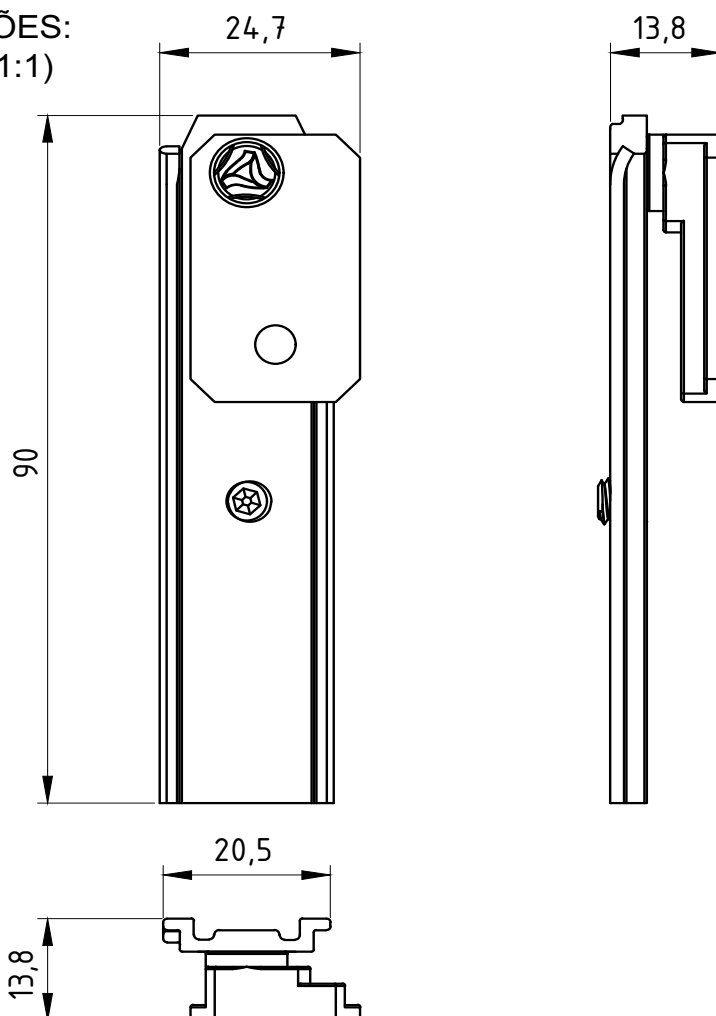

CARACTERÍSTICAS:

Componentes:	Matéria-prima:
Estrutura	Alumínio
Rebite	Alumínio
Guia	Poliamida
Parafuso allen	Aço Inox
Paraf. fenda cruzada	Aço Inox

Acabamento Anodizado e Pintado		
Preto	Fosco	Branco

Embalagem	10 Pares
	40 Parafusos

DETALHE DE APLICAÇÃO:
(Sem escala)

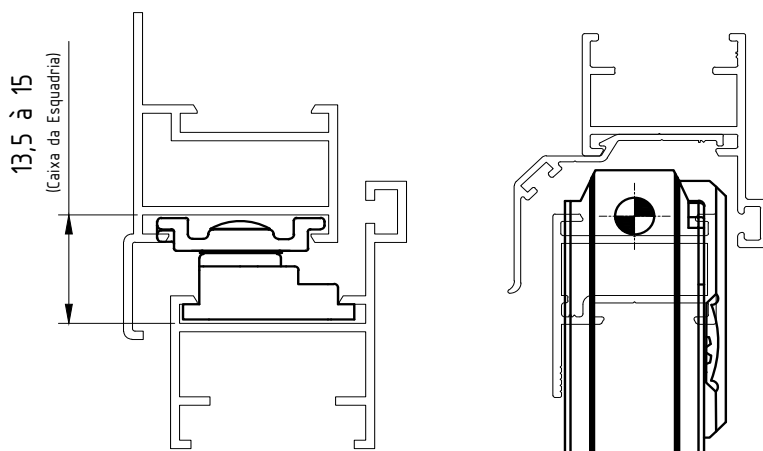

Código Preto	Código Fosco	Código Branco	Comp. (mm)	Altura (mm) Máxima	Largura (mm) Máxima	Peso (Kg) Admissível	Vidro (mm) Esp. Máxima
PIV-752	PIV-7520	PIV-752EB	90	600	800	6,2	4

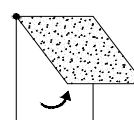

JANELA
PIVOTANTE

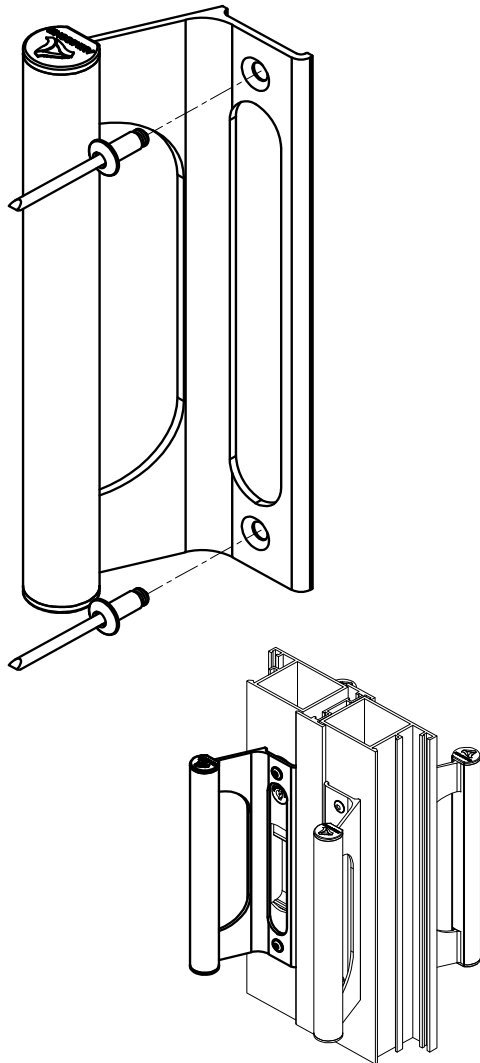

(escala 1:2)

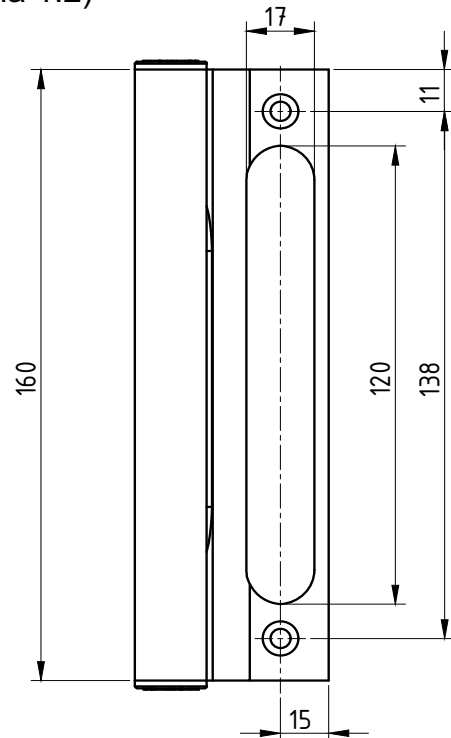

(escala 1:2)

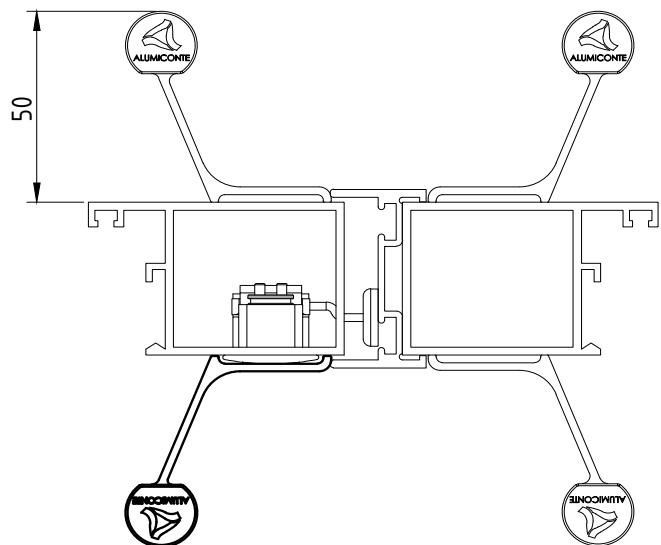

APLICAÇÃO NOS FECHOS

FEC-634	FEC-636
FEC-1035	FEC-1036
FEC-1037	FEC-1038

Componentes:

Matéria-prima:

Estrutura

Alumínio

Tampa

Poliamida

Rebite pop

Alumínio

Acabamento Anodizado e Pintado

Preto Branco Fosco Bronze

CÓDIGO

ACABAMENTO

PUX-648 PRETO

PUX-6480 FOSCO

PUX-648EB BRANCO

PUX-648BR BRONZE

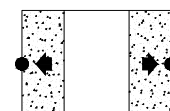

Janelas e portas de correr

Embalagem

01 puxador

02 rebites

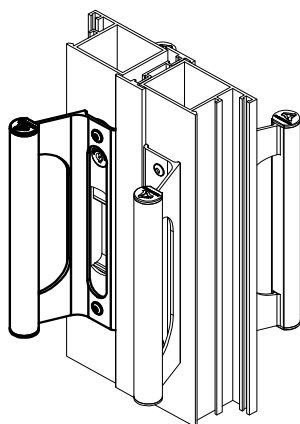
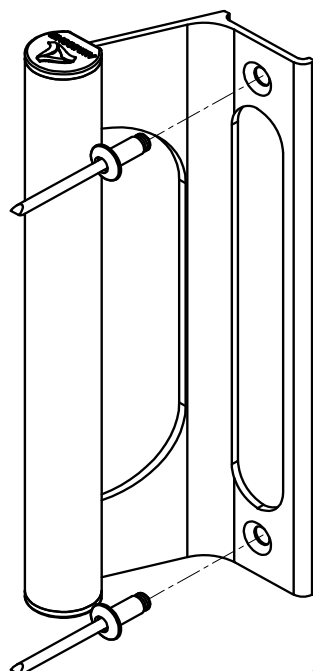

(escala 1:2)

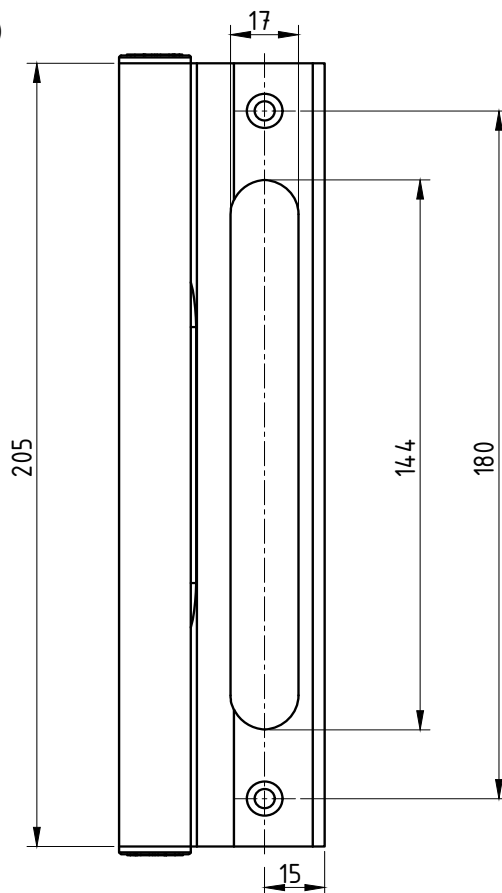

(escala 1:2)

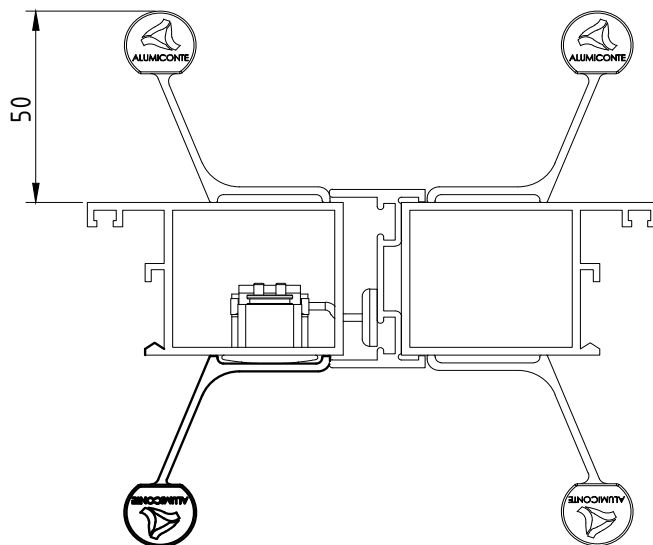

APLICAÇÃO NOS FECHOS

FEC-1041 FEC-1042
FEC-1039 FEC-1040

Componentes:	Matéria-prima:
Estrutura	Alumínio
Tampa	Poliamida
Rebite pop	Alumínio

Acabamento Anodizado e Pintado			
Preto	Branco	Fosco	Bronze

Embalagem	01 puxador
	02 rebites

CÓDIGO	ACABAMENTO
PUX-649	PRETO
PUX-6490	FOSCO
PUX-649EB	BRANCO
PUX-649BR	BRONZE

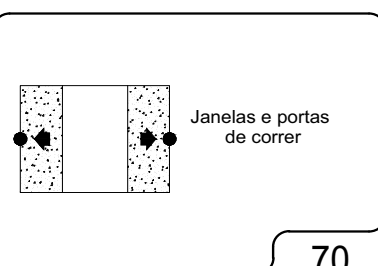

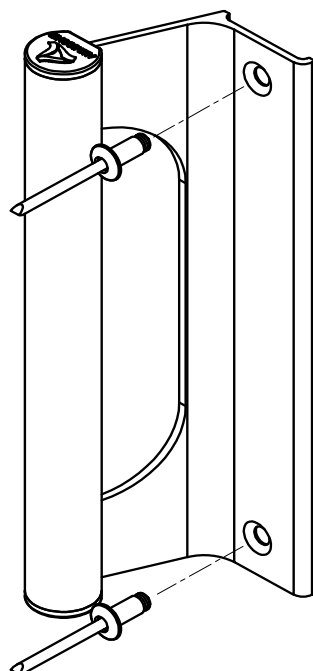

(escala 1:2)

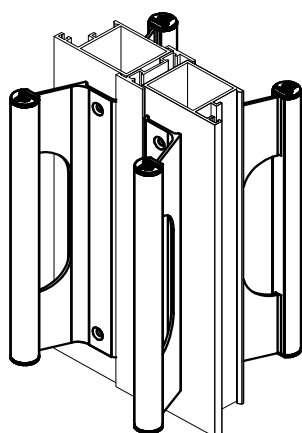
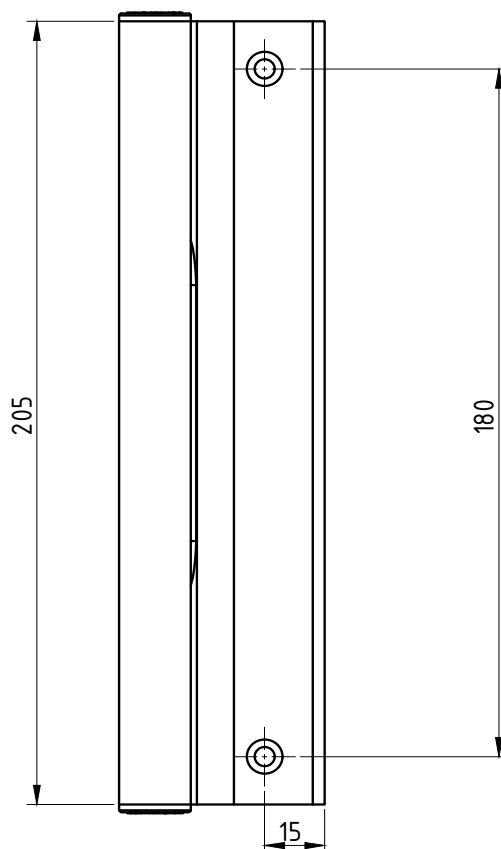

(escala 1:2)

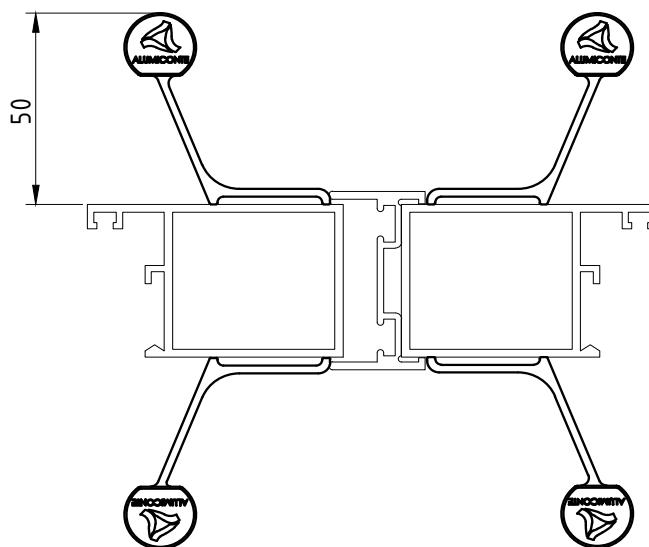

Componentes:	Matéria-prima:
Estrutura	Alumínio
Tampa	Poliamida
Rebite pop	Alumínio

Acabamento Anodizado e Pintado			
Preto	Branco	Fosco	Bronze

Embalagem	01 puxador
	02 rebites

CÓDIGO	ACABAMENTO
PUX-654	PRETO
PUX-6540	FOSCO
PUX-654EB	BRANCO
PUX-654BR	BRONZE

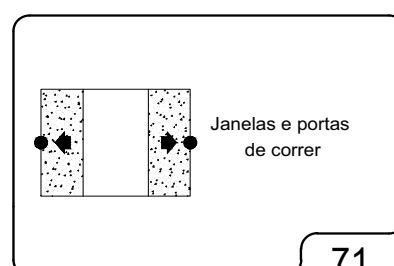

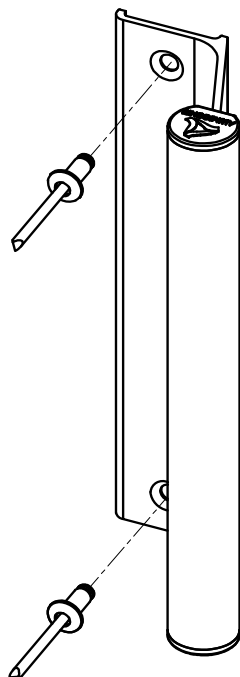

(escala 1:2)

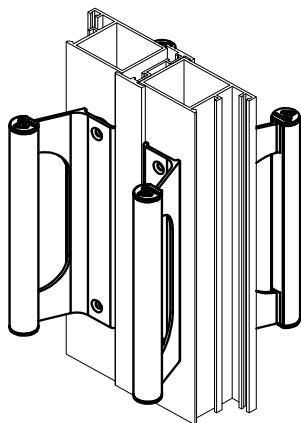
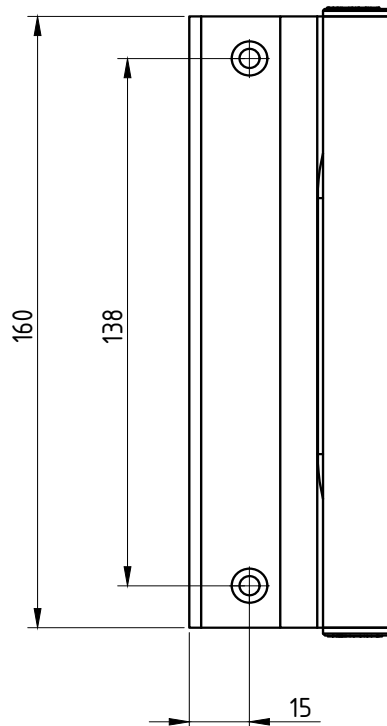

(escala 1:2)

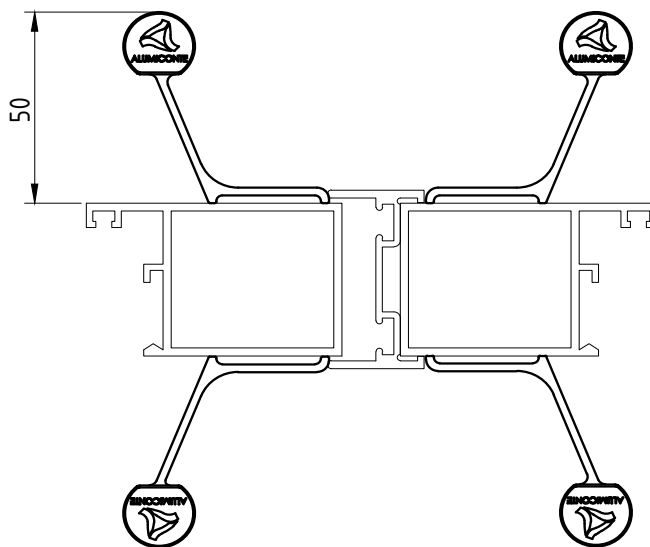

Componentes:	Matéria-prima:
Estrutura	Alumínio
Tampa	Poliamida
Rebite pop	Alumínio

Acabamento Anodizado e Pintado			
Preto	Branco	Fosco	Bronze

Embalagem	01 puxador
	02 rebites

CÓDIGO	ACABAMENTO
PUX-650	PRETO
PUX-6500	FOSCO
PUX-650EB	BRANCO
PUX-650BR	BRONZE

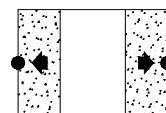

Janelas e portas de correr

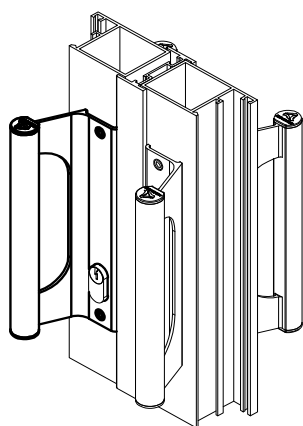
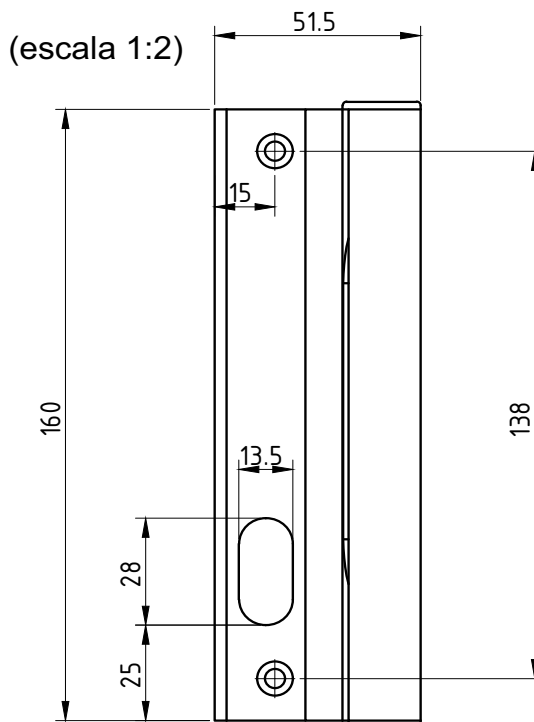
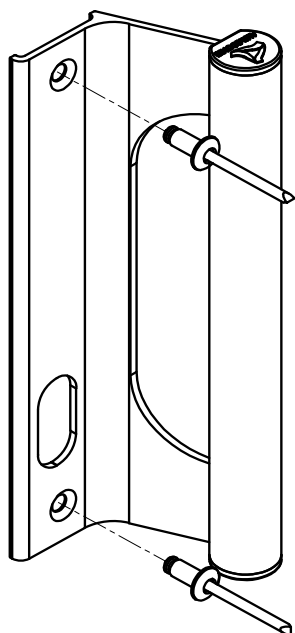

(escala 1:2)

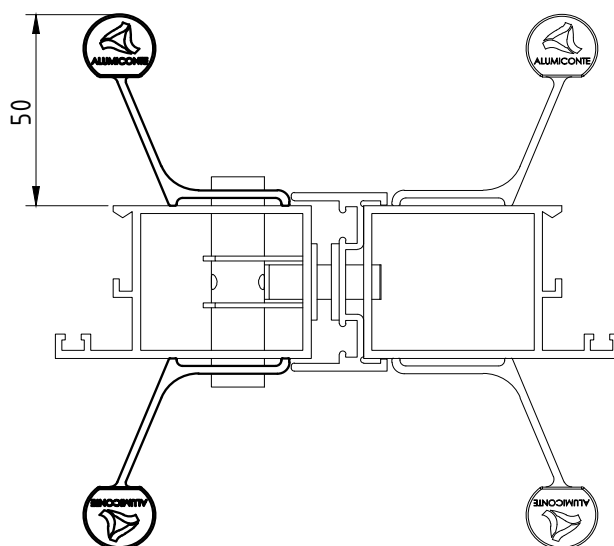

Componentes:	Matéria-prima:
Estrutura	Alumínio
Tampa	Poliamida
Rebite pop	Alumínio

Acabamento Anodizado e Pintado			
Preto	Branco	Fosco	Bronze

Embalagem	01 puxador
	02 rebites

CÓDIGO	ACABAMENTO
PUX-652(direito)	PRETO
PUX-6520(direito)	FOSCO
PUX-652EB(direito)	BRANCO
PUX-652BR(direito)	BRONZE
PUX-653(esq.)	PRETO
PUX-6530(esq.)	FOSCO
PUX-653EB(esq.)	BRANCO
PUX-653BR(esq.)	BRONZE

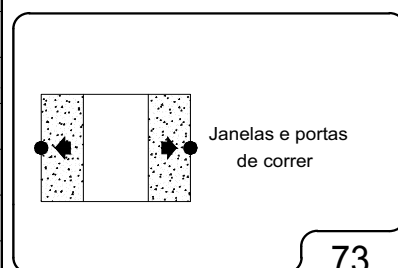

DIMENSÕES:
(escala 1:2)

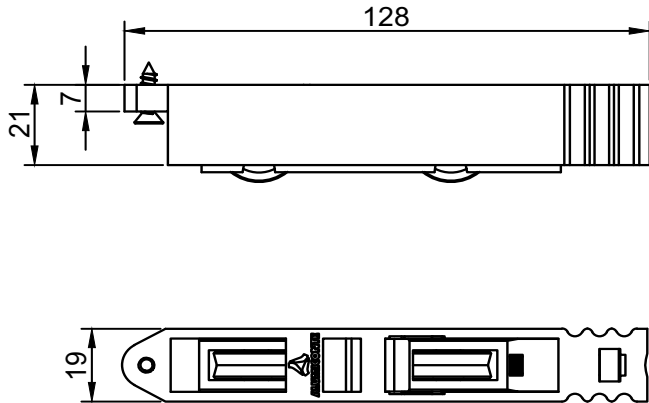

PERSPECTIVA:
(sem escala)

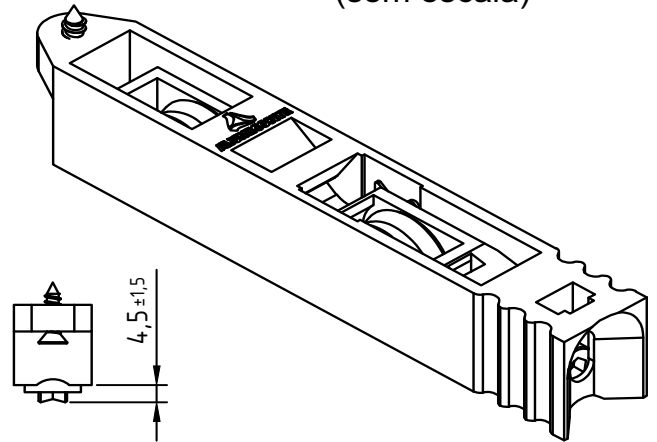

DETALHE DE MONTAGEM:
(escala 1:2,5)

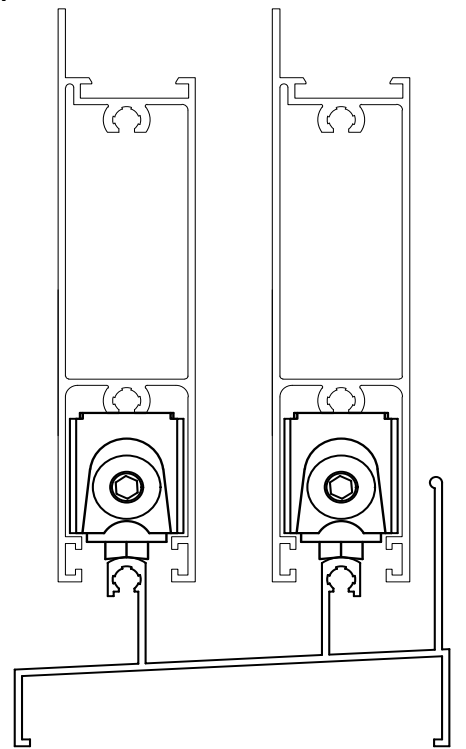

Regulagem de altura: $\pm 3\text{mm}$

CARACTERÍSTICAS:

Componentes:	Matéria-prima:
Cavalete	Poliamida
Suporte para roda	Poliamida fibra
Eixos	Latão
Parafusos	Aço Inox
Rolamentos	Importado
Rodas	Poliamida

Código:	Carga Máxima:
ROL 439R (Com Rolamento)	40 kg por Roldana
ROL 439 (Sem Rolamento)	20 kg por Roldana

Embalagem	20 Roldanas
-----------	-------------

CÓDIGO	ACABAMENTO
ROL-439R (Com Rolamento)	Preto
ROL-439 (Sem Rolamento)	Preto

**JANELAS E
PORTAS
DE CORRER**

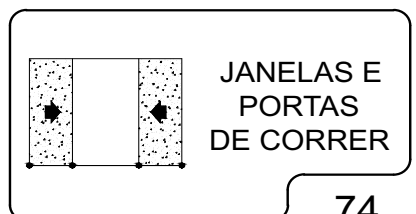

PERSPECTIVA:
(sem escala)

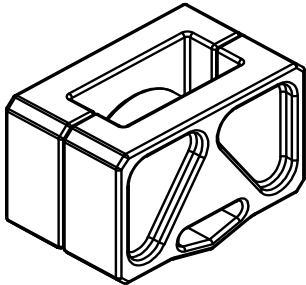

DIMENSÕES:
(escala 1:2)

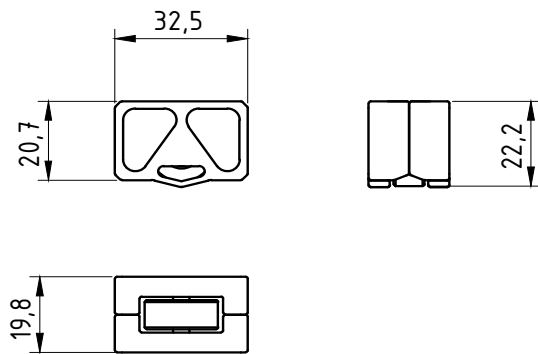

DETALHE DE MONTAGEM:
(escala 1:1)

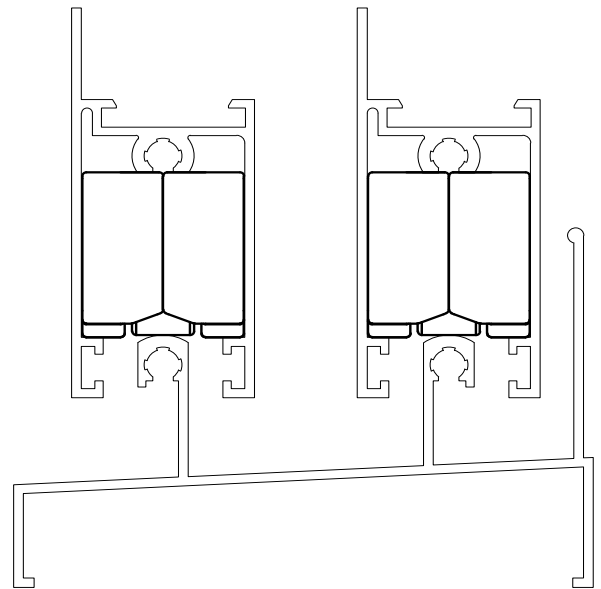

Carga Máxima: 7,5Kg Por Roldana

CARACTERÍSTICAS:

Componentes:	Matéria-prima:
Estrutura	Poliamida
Eixo	Alumínio
Roda	Poliamida

Embalagem	50 Roldanas
-----------	-------------

CÓDIGO	ACABAMENTO
ROL-427	Preto

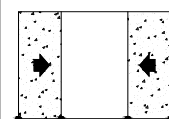

JANELAS
DE CORRER

PERSPECTIVA:
(escala 1:1)

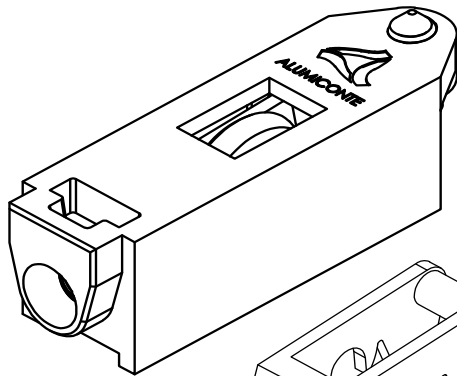

ROL426 e ROL440R
Cavalete em Zamac

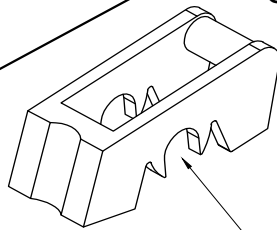

ROL0426N e ROL0440NR
Cavalete em Poliamida

DIMENSÕES:
(escala 1:1)

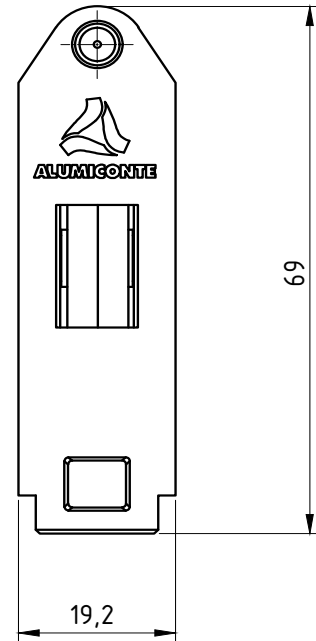
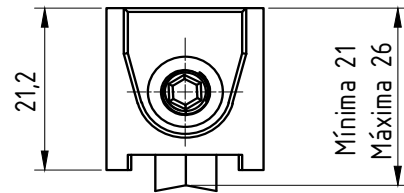

DETALHE DE APLICAÇÃO:
(sem escala)

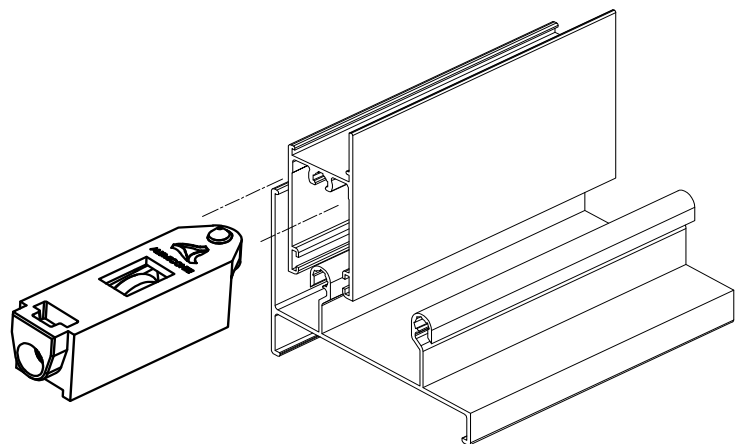

CARACTERÍSTICAS:

Componentes:	Matéria-prima:
Cavalete	Poliamida
Cavalete	Zamac
Rolamento	Aço
Roda	Poliamida
Eixo	Alumínio
Parafusos	Aço Inox

Código:	Carga Máxima:
ROL426	10 kg Por Roldana
ROL0426N	10 kg Por Roldana
ROL0440NR	20 kg Por Roldana
ROL440R	20 kg Por Roldana

Código:	Aplicado:
ROL426	Janelas de Correr
ROL0426N	Janelas de Correr
ROL0440NR	Janelas e Portas de Correr
ROL440R	Janelas e Portas de Correr

Embalagem	20 Roldanas
-----------	-------------

CÓDIGO	ACABAMENTO
ROL426 (sem rolamento)	Preto
ROL0426N (sem rolamento)	Preto
ROL0440NR (com rolamento)	Preto
ROL440R (com rolamento)	Preto

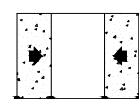

JANELAS E
PORTAS
DE CORRER

DIMENSÕES:
(escala 1:1)

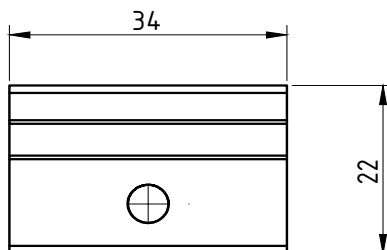
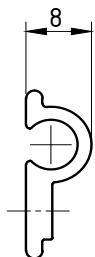

DETALHE DE APLICAÇÃO:
(sem escala)

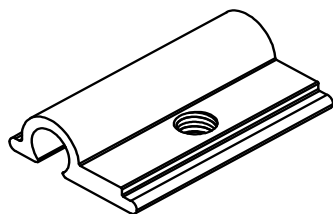

DETALHE DE APLICAÇÃO:
(sem escala)

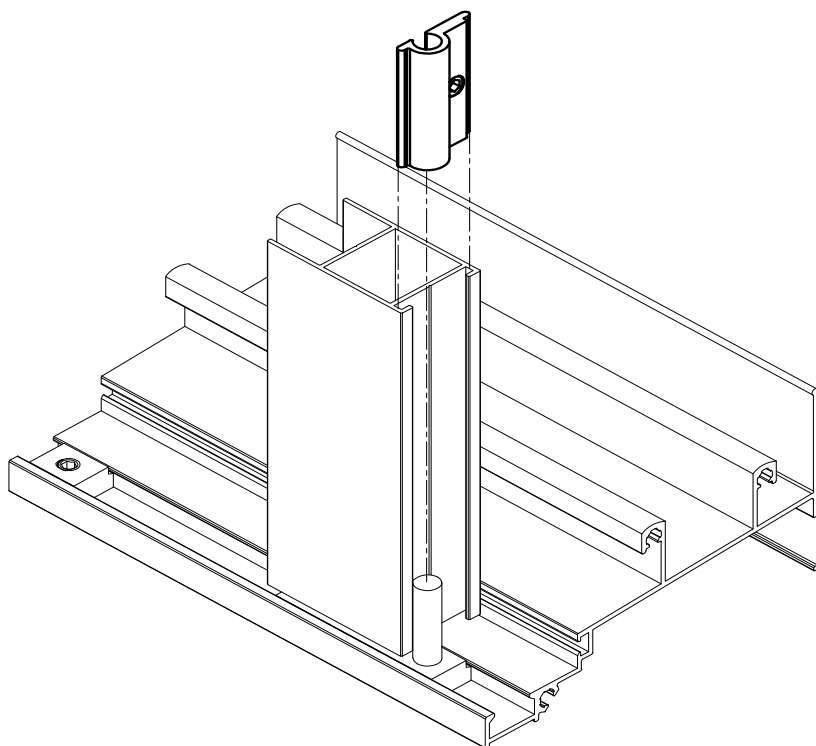

CARACTERÍSTICAS:

Componentes:	Matéria-prima:
Estrutura	Alumínio
Parafuso	Aço inox

Acabamentos

Preto

Branco

Embalagem

100 peças

CÓDIGO	ACABAMENTO
SUP-624	PRETO
SUP-624EB	BRANCO

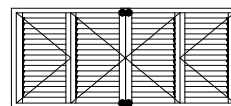

JANELAS CAMARÃO

Setembro/2018

S/ESCALA

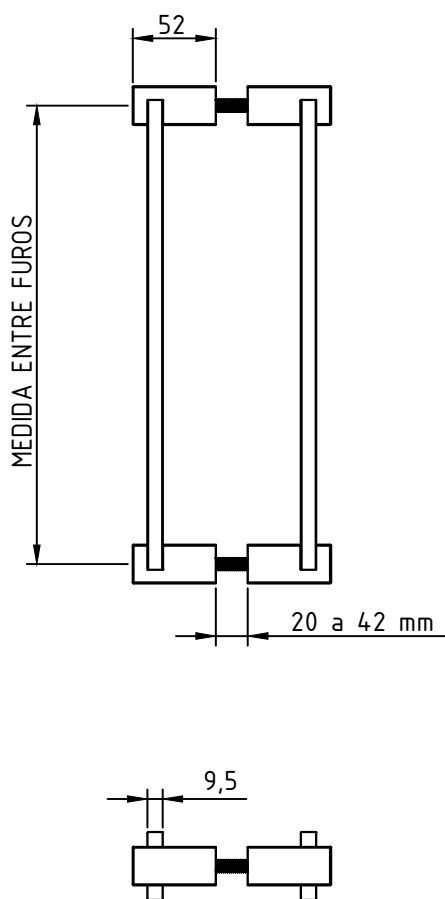

PERSPECTIVA S/ESCALA

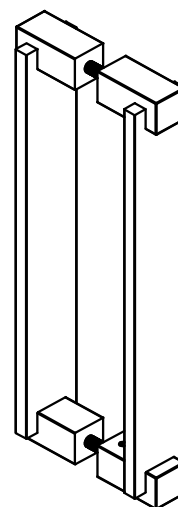

Componentes:	Matéria-prima:
Estrutura	Alumínio
Parafusos	Aço Inox
Barra roscada	Aço Zincado

Acabamento Pintado		
Branco	Prata	Preto

Embalagem	01 par de puxadores
	01 Kit de Fixação

CÓDIGO	ACAB./TAM. entre furos
PUX1030BC	BRANCO/300 mm
PUX1030FS	PRATA/300 mm
PUX1030PT	PRETO/300 mm
PUX1050BC	BRANCO/500 mm
PUX1050FS	PRATA/500 mm
PUX1050PT	PRETO/500 mm
PUX1070BC	BRANCO/700 mm
PUX1070FS	PRATA/700 mm
PUX1070PT	PRETO/700 mm
PUX1090BC	BRANCO/900 mm
PUX1090FS	PRATA/900 mm
PUX1090PT	PRETO/900 mm
PUX1110BC	BRANCO/1100 mm
PUX1110FS	PRATA/1100 mm
PUX1110PT	PRETO/1100 mm



S/ESCALA

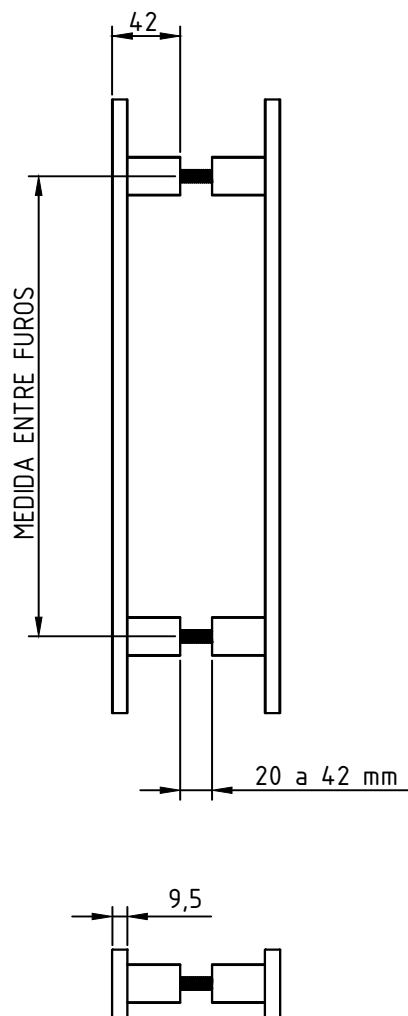

**PERSPECTIVA
S/ESCALA**

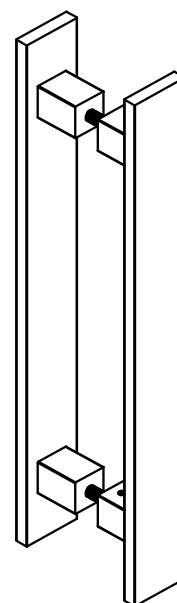

Componentes:	Matéria-prima:
Estrutura	Alumínio
Parafusos	Aço Inox
Barra roscada	Aço Zincado

Acabamento Pintado		
Branco	Prata	Preto

Embalagem	01 par de puxadores
	01 Kit de Fixação

CÓDIGO	ACAB./TAM. entre furos
PUX2030BC	BRANCO/300 mm
PUX2030FS	PRATA/300 mm
PUX2030PT	PRETO/300 mm
PUX2050BC	BRANCO/500 mm
PUX2050FS	PRATA/500 mm
PUX2050PT	PRETO/500 mm
PUX2070BC	BRANCO/700 mm
PUX2070FS	PRATA/700 mm
PUX2070PT	PRETO/700 mm
PUX2090BC	BRANCO/900 mm
PUX2090FS	PRATA/900 mm
PUX2090PT	PRETO/900 mm
PUX2110BC	BRANCO/1100 mm
PUX2110FS	PRATA/1100 mm
PUX2110PT	PRETO/1100 mm



Setembro/2018

S/ESCALA

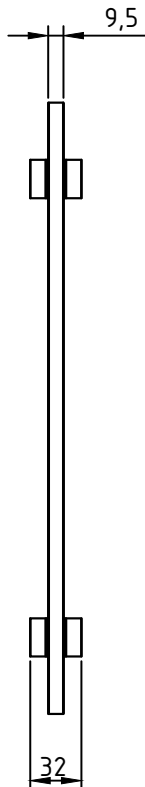
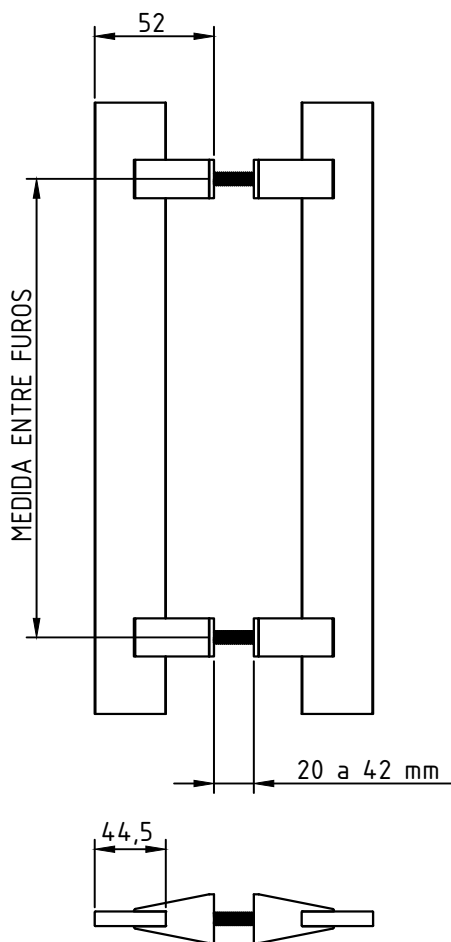

PERSPECTIVA S/ESCALA

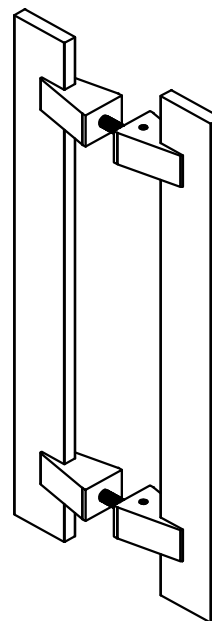

Componentes:	Matéria-prima:
Estrutura	Alumínio
Parafusos	Aço Inox
Barra roscada	Aço Zincado

Acabamento Pintado		
Branco	Prata	Preto

Embalagem	01 par de puxadores
	01 Kit de Fixação

CÓDIGO	ACAB./TAM. entre furos
PUX3030BC	BRANCO/300 mm
PUX3030FS	PRATA/300 mm
PUX3030PT	PRETO/300 mm
PUX3050BC	BRANCO/500 mm
PUX3050FS	PRATA/500 mm
PUX3050PT	PRETO/500 mm
PUX3070BC	BRANCO/700 mm
PUX3070FS	PRATA/700 mm
PUX3070PT	PRETO/700 mm
PUX3090BC	BRANCO/900 mm
PUX3090FS	PRATA/900 mm
PUX3090PT	PRETO/900 mm
PUX3110BC	BRANCO/1100 mm
PUX3110FS	PRATA/1100 mm
PUX3110PT	PRETO/1100 mm



PORTAS DE GIRO

Abril/2017

ATENÇÃO!
VERIFICAR A TENSÃO CORRETA (V).

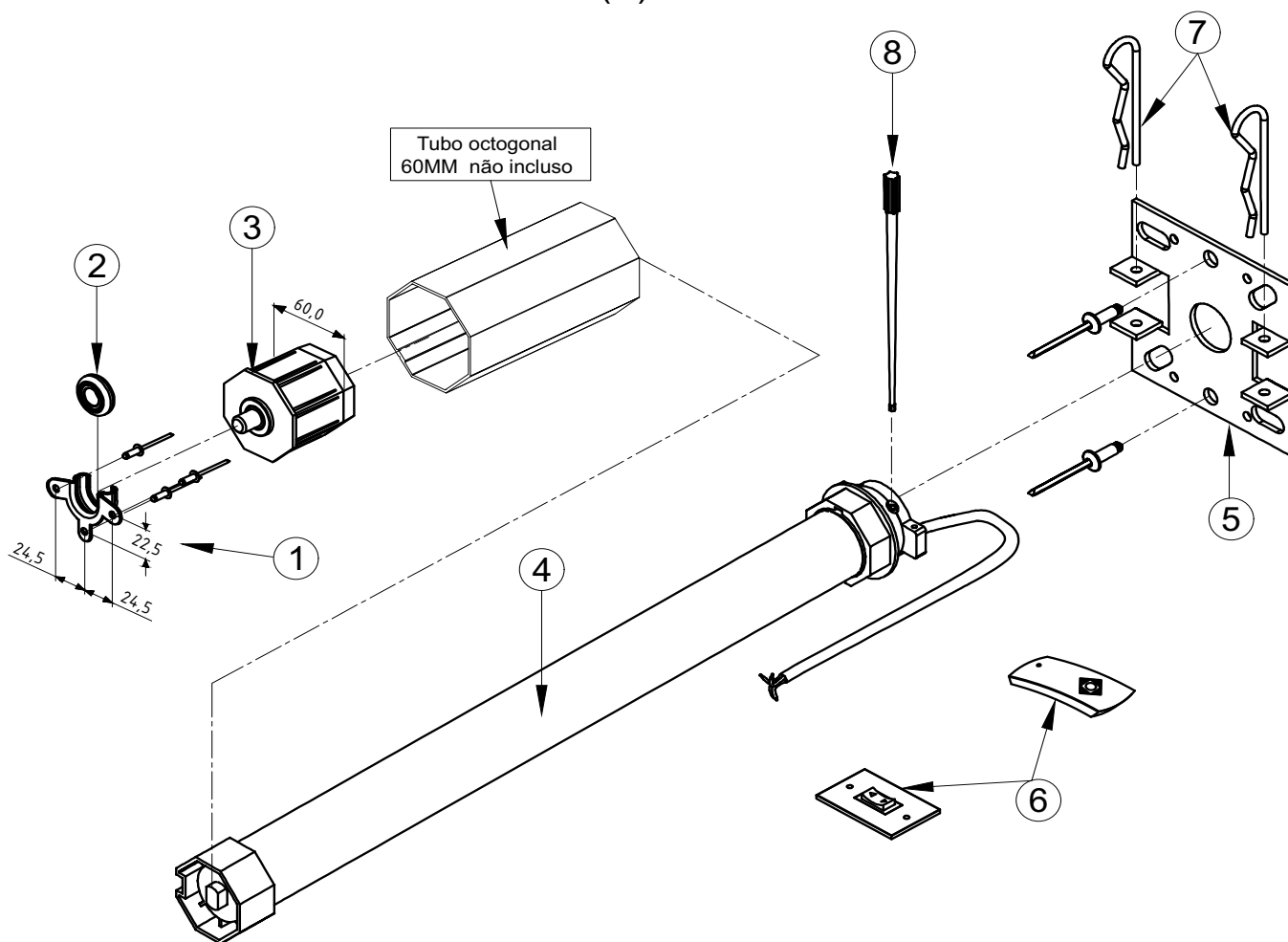

PESO MÁXIMO DA PERSIANA: 60Kg

CARACTERÍSTICAS:

N:	Componentes:	Matéria-prima:
1	Mancal do Reolhedor	Aço
2	Rolamento do Mancal	Aço / Poliamida
3	Ponteira de Eixo 60mm	Aço / ABS
4	Motor	Aço / Poliamida
5	Suporte	Aço
6	controle ou interruptor	Poliamida
7	Grampo	Aço
8	Chave regulagem	Poliamida

Componentes p/ Fixação:	Matéria-prima:
Parafusos	Aço Inox
Rebites	Alumínio

Acabamentos:	
Preto	

Embalagem	1 Conjunto
-----------	------------

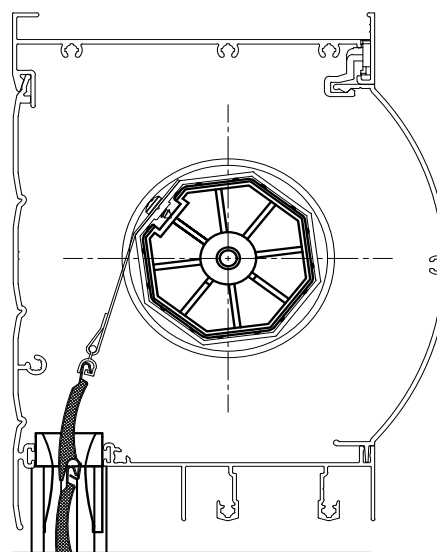

Código	DESCRIÇÃO
MA-R40-220	C/C-220V
MA-R40-110	C/C-110V
MA-40-220	C/I-220V
MA-40-110	C/I-110V

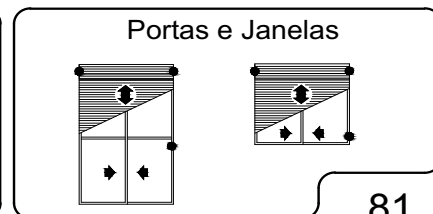

PERSPECTIVA:
(escala 1:1)

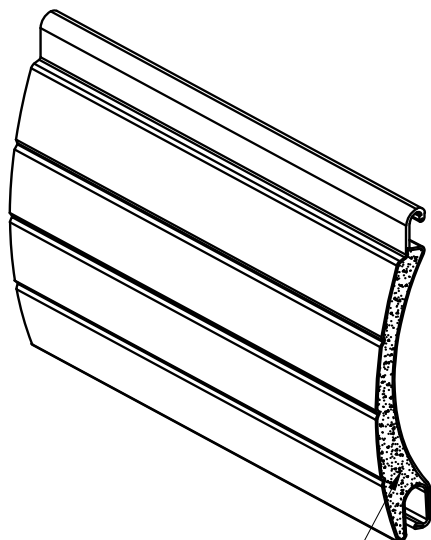

Poliuretano
injetado

DIMENSÕES:
(escala 1:1)

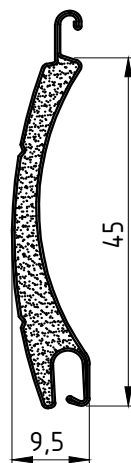

DETALHE DE APLICAÇÃO:
(sem escala)

NYL - 447

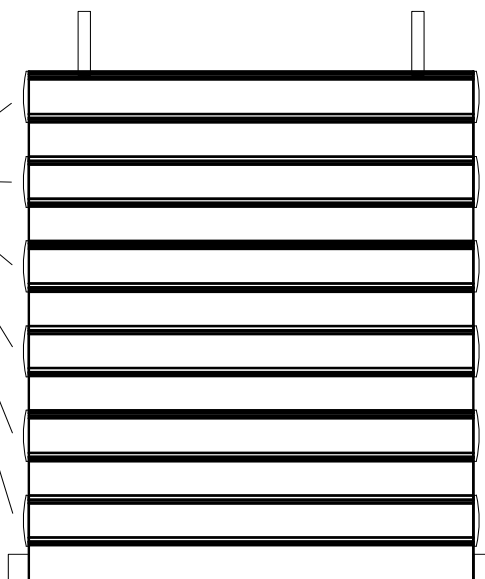

DIMENSÕES PARA ROLO DA ESTEIRA

Altura em Metro Linear	1300	1600	2400	2800
Diametro do Rolo da Esteira	124	128	154	158

Dimensões considerando eixo 40mm e perfil terminal.
Medidas em mm.

CARACTERÍSTICAS:

Componentes:	Matéria-prima:
Estrutura	Alumínio 3105 H46

Peso (Kg/m ²)	Aproxim. 2,5 Kg/m ²
Densidade de espuma	70-90 kg/m ³

Embalagem	Barras de 5.8 metros Pacotes de 60 peças
-----------	---

ORIENTAÇÃO DE MONTAGEM PARA NÃO OCORRER O DESALINHAMENTO DAS PERSIANAS DURANTE A MOVIMENTAÇÃO DA ESTEIRA.

CÓDIGO	ACABAMENTO
VZP-0310BC	Branca / Vent.
VZP-1100BC	Branca / Cega
VZP-0140BZ	Bronze / Vent.
VZP-1120BZ	Bronze / Cega
VZP-0320FS	Prata / Vent.
VZP-1110FS	Prata / Cega
VZP-0330PT	Preta / Vent.
VZP-1130PT	Preta / Cega

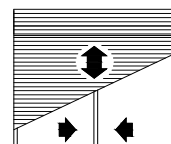

PERSIANAS

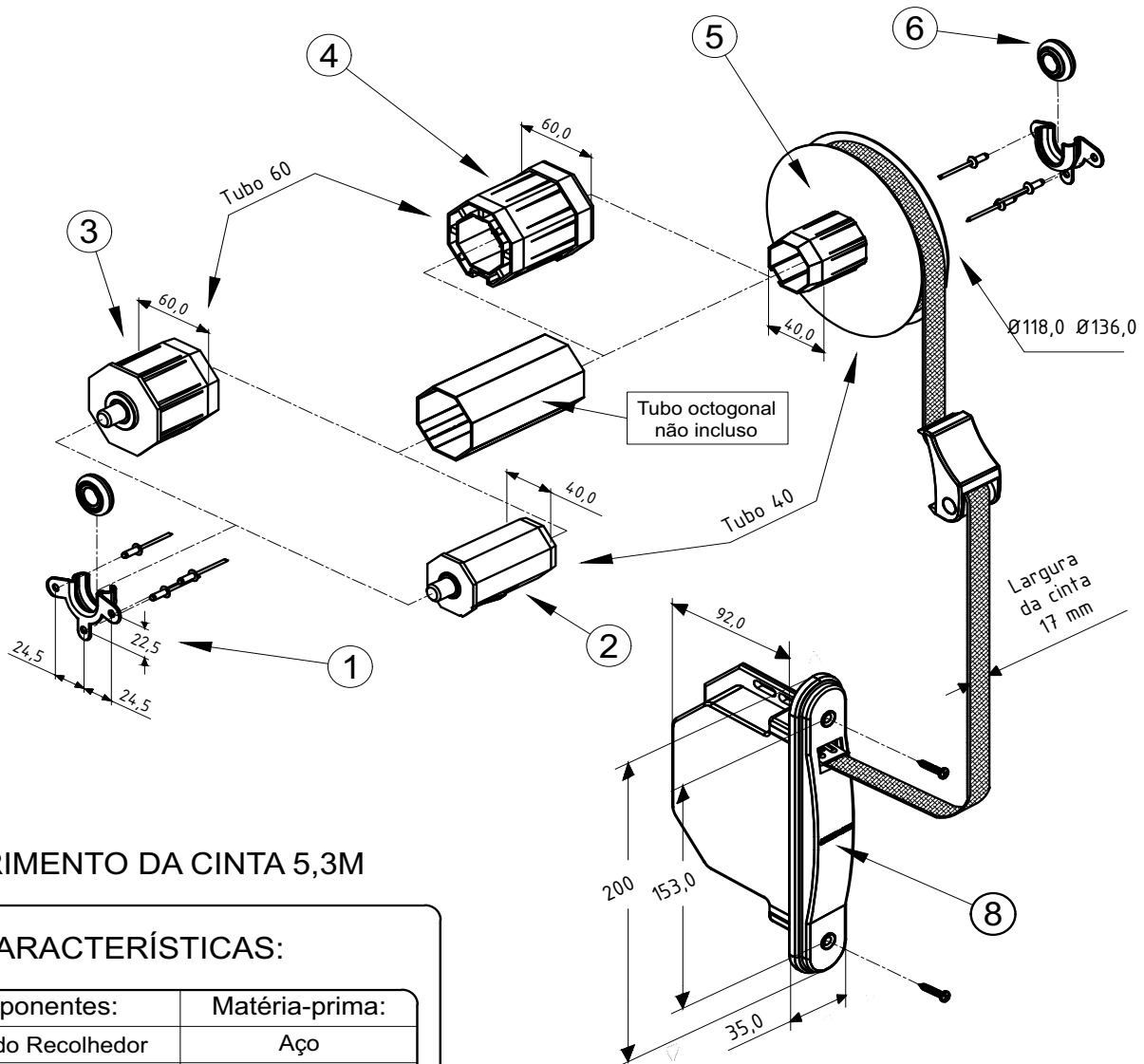

COMPRIMENTO DA CINTA 5,3M

CARACTERÍSTICAS:

N:	Componentes:	Matéria-prima:
1	Mancal do Recolhedor	Aço
2	Ponteira de Eixo 40mm	Aço / ABS
3	Ponteira de Eixo 60mm	Aço / ABS
4	Adaptador p/ Tubo 60mm	ABS
5	Polia Ø118,0	Aço / ABS
	Polia Ø136,0	Aço / ABS
6	Rolamento do Mancal	Aço / Poliamida
7	Guia da Cinta	Poliamida
8	Máquina c/ Espelho e Caixa	ABS / Aço

Componentes p/ Fixação:	Matéria-prima:
Parafusos	Aço Inox
Rebites	Alumínio

Acabamentos:	
Preto	Branco

Embalagem	1 Conjunto
-----------	------------



Código Preto	Código Branco	Tubo (mm)	Polia (mm)	Aplicação
REC - 120	REC - 120 EB	40	Ø118,0	Janela
REC - 121	REC - 121EB	40	Ø136,0	Porta
REC - 122	REC - 122 EB	60	Ø118,0	Janela
REC - 123	REC - 123 EB	60	Ø136,0	Porta

PERSIANA

Portas e Janelas

Peso Máximo: 12Kg
Altura máxima da Porta: 2,40 m

Fixação do
Mancal

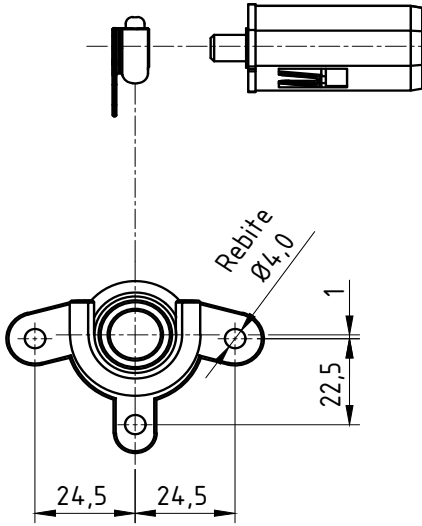

Tubo octogonal
não incluso

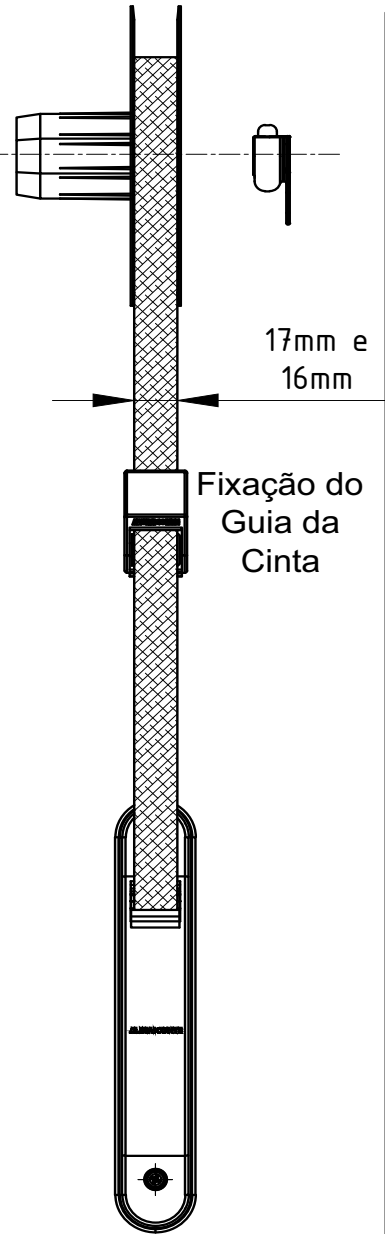
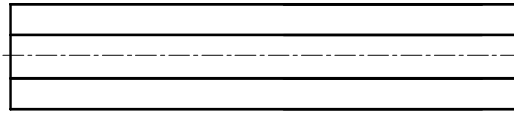

Corte do Tubo

- Tubo 40

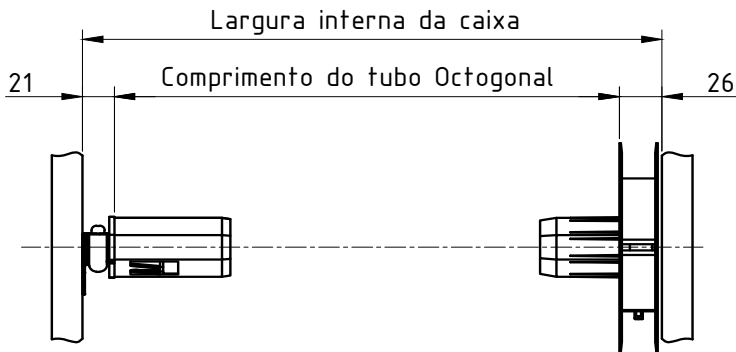

- Tubo 60

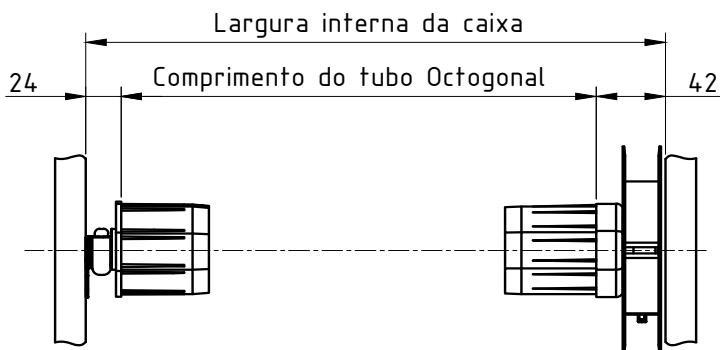

Fixação das Máquinas

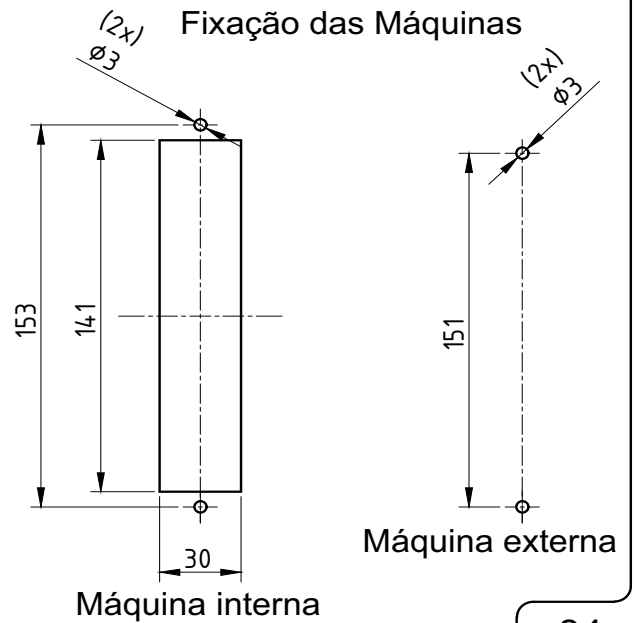

INSTRUÇÕES DE MONTAGEM
DO RECOLHEDOR

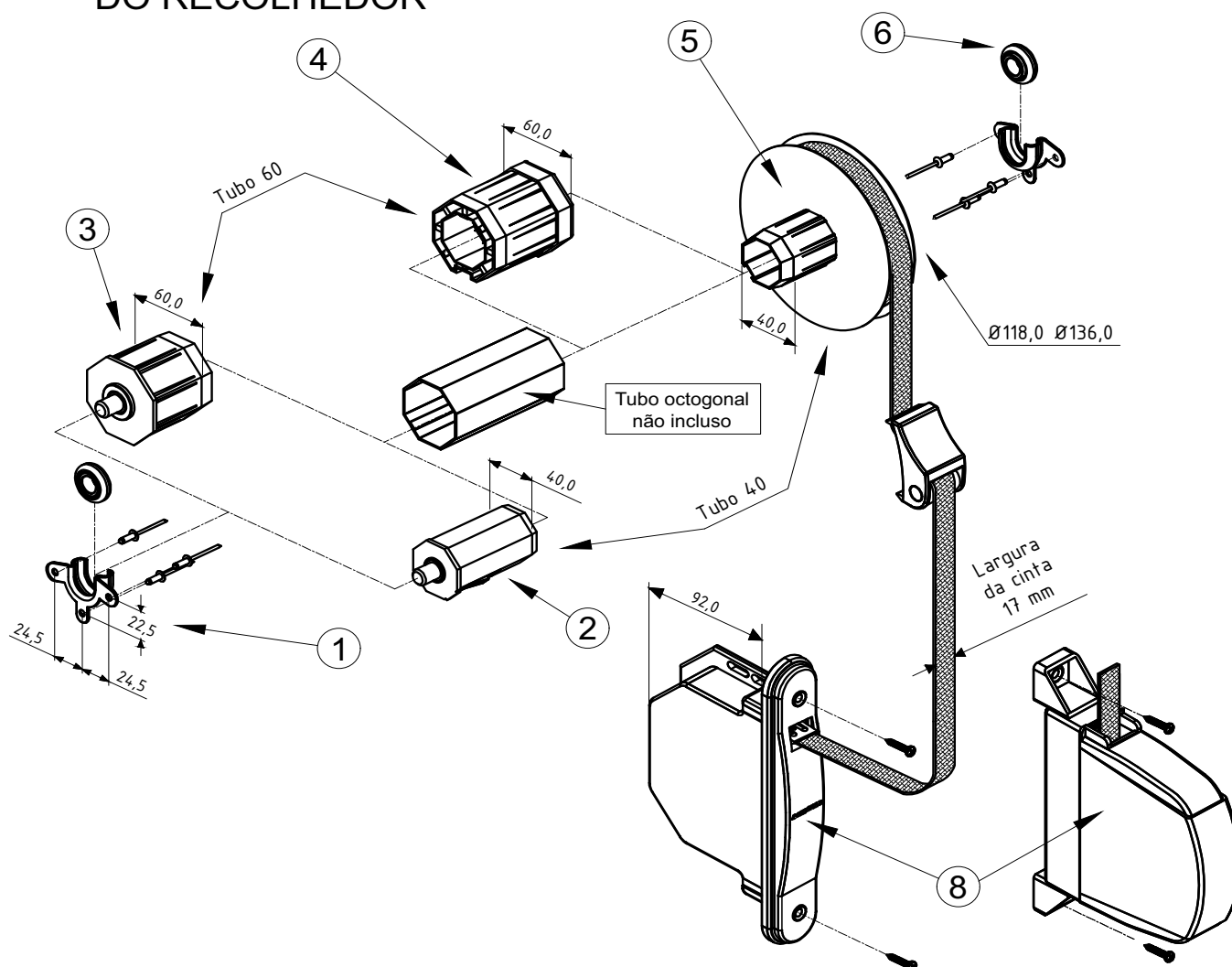

Instruções

- Fixar a Máquina interna ou externa (8) na esquadria;
- Prender os Mancais (1) centralizados na caixa;
- Montar a Polia (5), o Adaptador (4) para tubos de 60mm, o Tubo e a Ponteira (2 ,3 ou 9) de acordo com a aplicação e a largura da caixa;
- Passar a Cinta (7) pela Guia (6) e pela Tampa da esquadria, fixá-la na Polia (5);
- Enrolar a Cinta (7) na polia (5) até que a máquina (8) fique toda tensionada;
- Deixar de 3 a 4 voltas de cinta (7) na máquina para garantir o bom funcionamento do recolhedor;
- 7°- Fixar a esteira no tubo octogonal.

DETALHE DE APLICAÇÃO:
(sem escala)

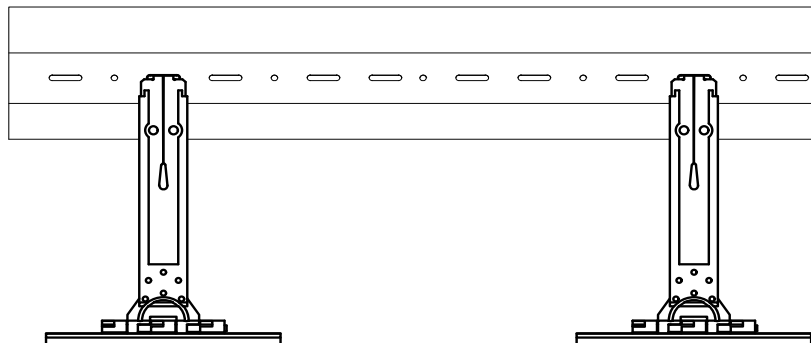

PERSPECTIVA:
(sem escala)

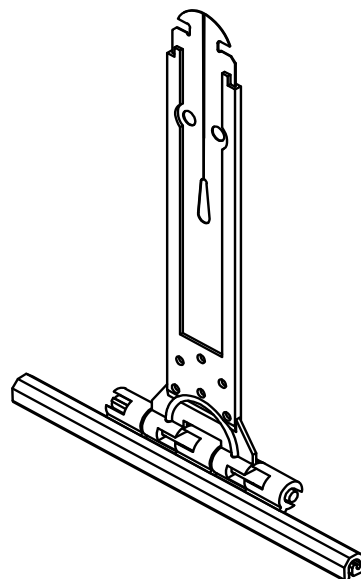

DIMENSÕES:
(escala 1:2)

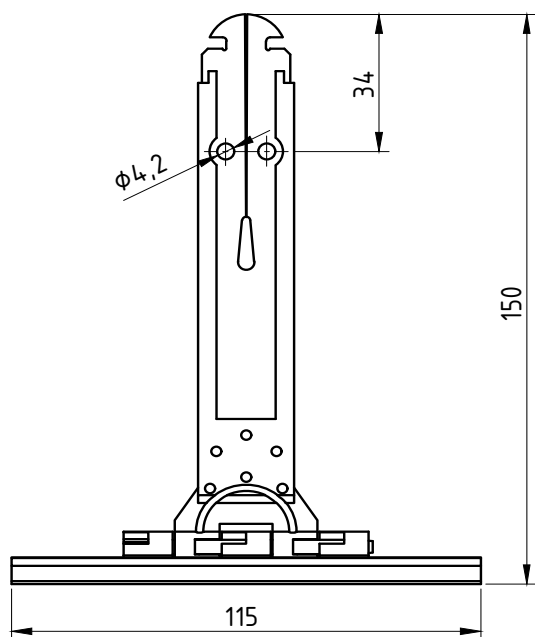

DETALHE DE APLICAÇÃO:
(sem escala)

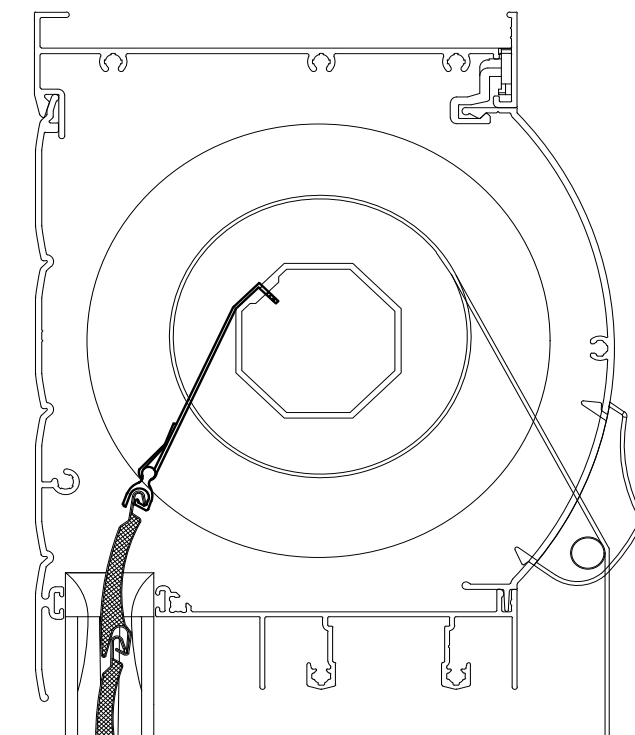

CARACTERÍSTICAS:

Componentes:	Matéria-prima:
Estrutura	Poliamida/Aço mola

Acabamento **NATURAL**

Embalagem **100 Peças**

CÓDIGO	ACABAMENTO
FIT-148	NATURAL

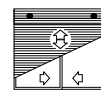
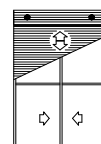

Portas e Janelas

PERSIANAS

DIMENSÕES:
(escala 1:2)

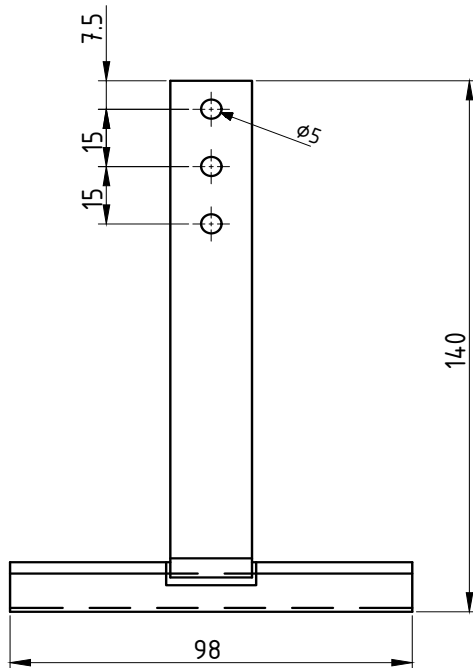

PERSPECTIVA:
(sem escala)

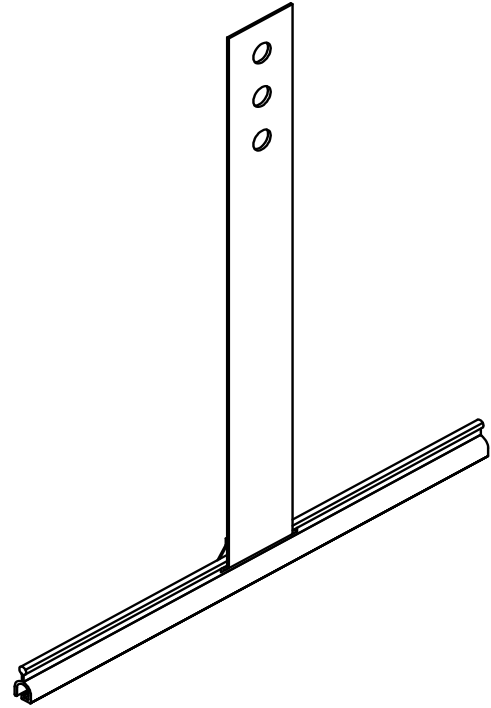

DETALHE DE APLICAÇÃO:
(sem escala)

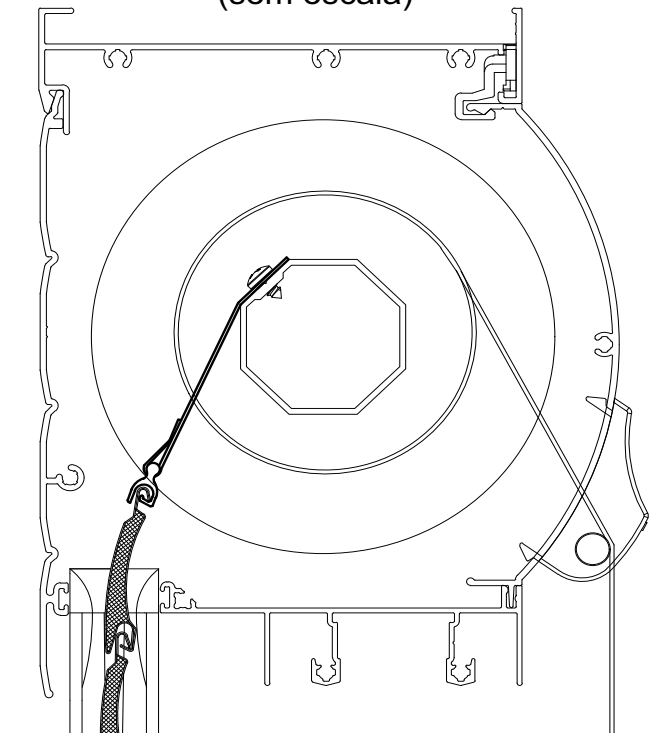

CARACTERÍSTICAS:

Componentes:	Matéria-prima:
Estrutura	Alumínio/Aço mola

Acabamento	Cinza
------------	-------

Embalagem	100 Peças
-----------	-----------

CÓDIGO	ACABAMENTO
FIT-749	Cinza

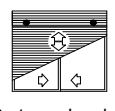
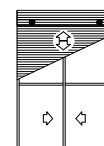

Portas e Janelas

PERSIANAS

DIMENSÕES:
(escala 1:2)

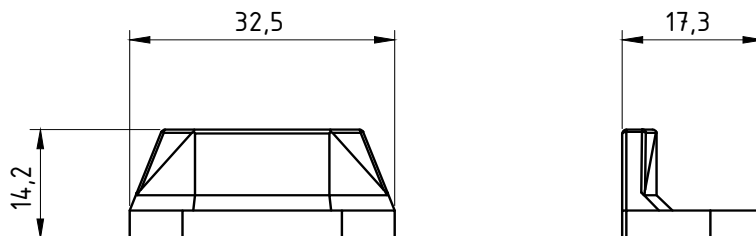

PERSPECTIVA:
(Sem escala)

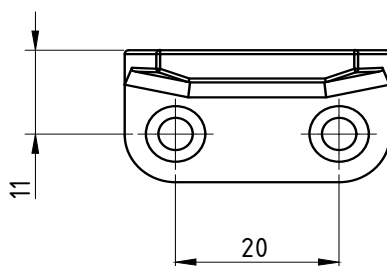
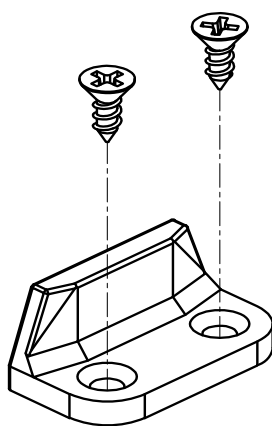

DETALHE DE APLICAÇÃO:
(sem escala)

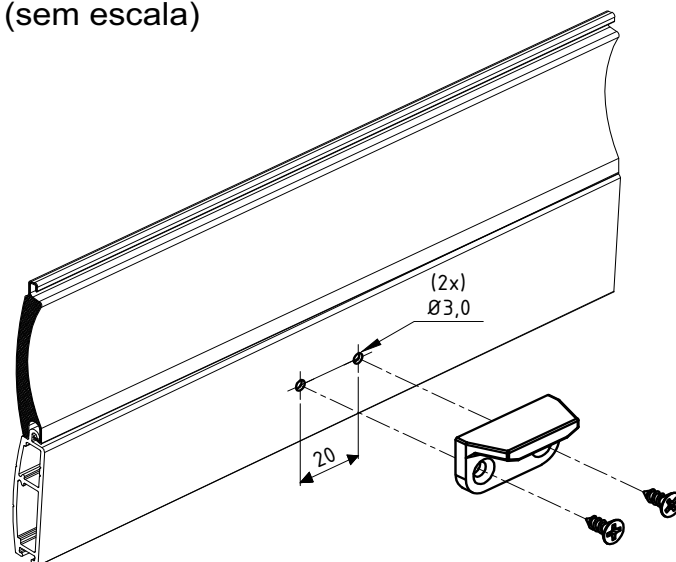

CARACTERÍSTICAS:

Componentes:	Matéria-prima:
Estrutura	Poliamida
Parafusos	Aço Inox

Acabamentos	
Preto	Branco

Embalagem	100 Limitadores
	200 Parafusos

CÓDIGO	ACABAMENTO
NYL-738	Preto
NYL-738NB	Branco

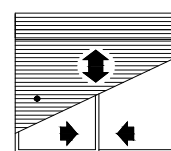

PERSIANA

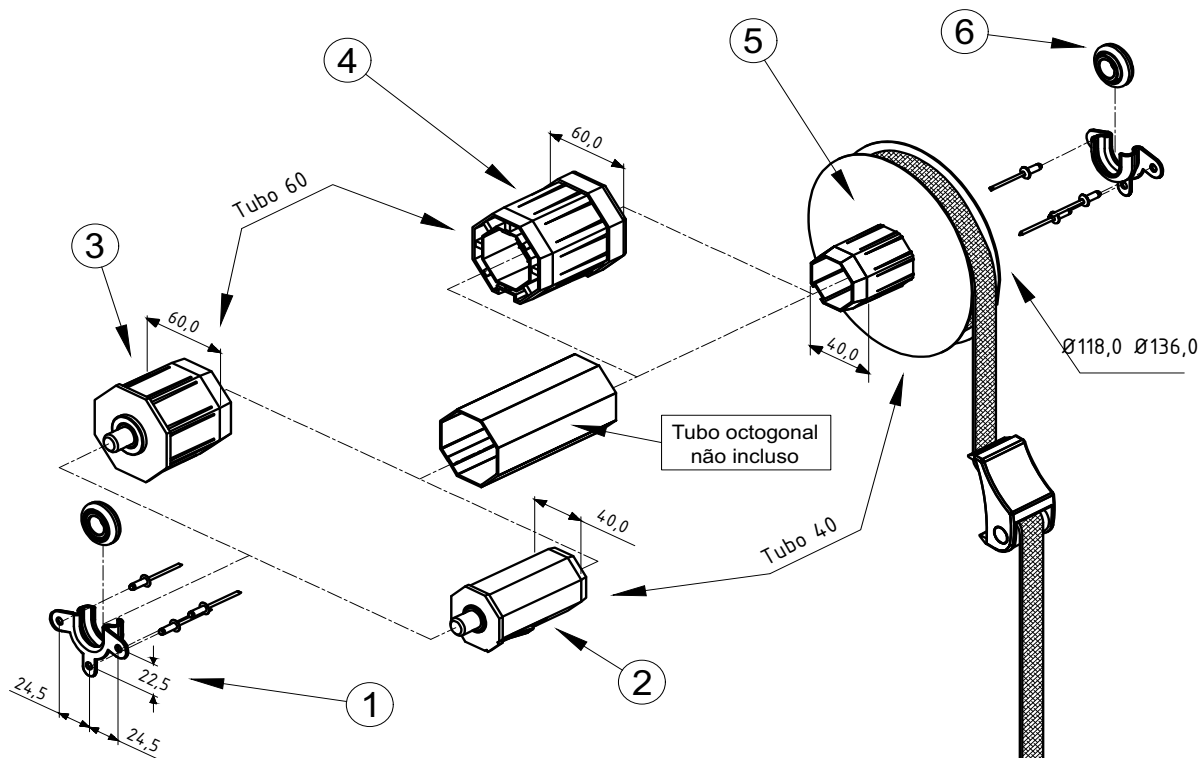

COMPRIENTO DA CINTA 5,3M

CARACTERÍSTICAS:

N:	Componentes:	Matéria-prima:
1	Mancal do Recolhedor	Aço
2	Ponteira de Eixo 40mm	Aço / ABS
3	Ponteira de Eixo 60mm	Aço / ABS
4	Adaptador p/ Tubo 60mm	ABS
5	Polia Ø118,0	Aço / ABS
	Polia Ø136,0	Aço / ABS
6	Rolamento do Mancal	Aço / Poliamida
7	Guia da Cinta	Poliamida
8	Máquina externa	Poliamida
9	Parafuso	aço inox

Componentes p/ Fixação:	Matéria-prima:
Parafusos	Aço Inox
Rebites	Alumínio

Acabamentos:	
Preto	Branco

Embalagem	1 Conjunto
-----------	------------

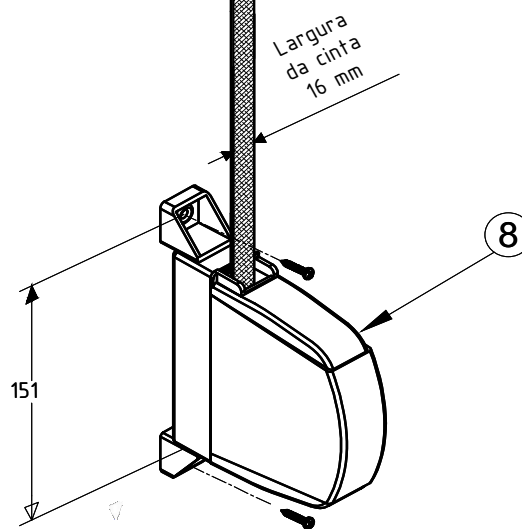

GUI-1151



Guia da cinta do recolhedor em Poliamida

Código Preto	Código Branco	Tubo (mm)	Polia (mm)	Aplicação
REC - 124	REC - 124 EB	40	Ø118,0	Janela
REC - 125	REC - 125EB	40	Ø136,0	Porta
REC - 126	REC - 126 EB	60	Ø118,0	Janela
REC - 127	REC - 127 EB	60	Ø136,0	Porta

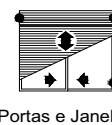
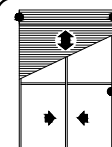

Portas e Janelas

PERSIANA

Peso Máximo: 12Kg
Altura máxima da Porta: 2,40 m

DIMENSÕES:
(escala 1:1)

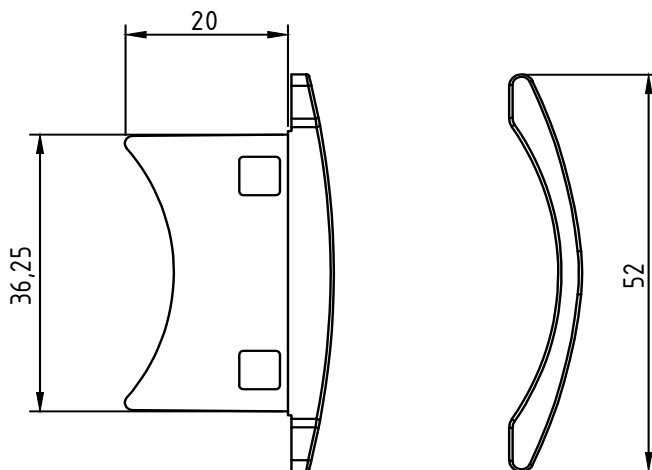

PERSPECTIVA:
(sem escala)

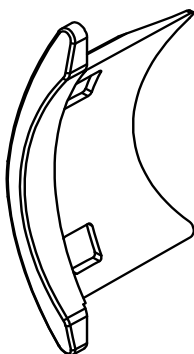

DETALHE DE APLICAÇÃO:
Sem Escala

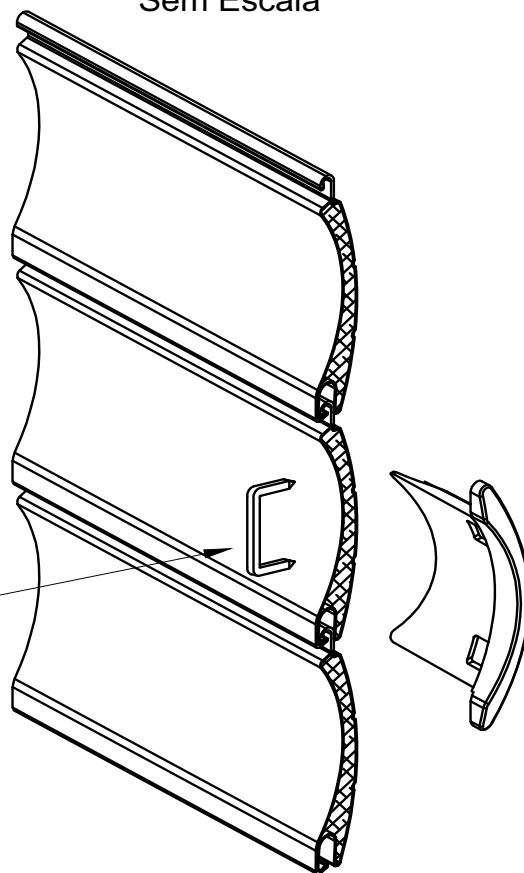

Grampo não fornecido

CARACTERÍSTICAS:

Componentes:	Matéria-prima:
Estrutura	Poliacetal
Embalagem	200 peças

CÓDIGO	ACABAMENTO
NYL 447	Preto

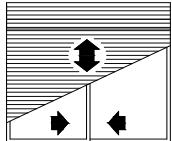

PERSIANA

DIMENSÕES:
(escala 1:1)

DETALHES DE APLICAÇÃO:
(sem escala)

TERM-01
0,408kg/m

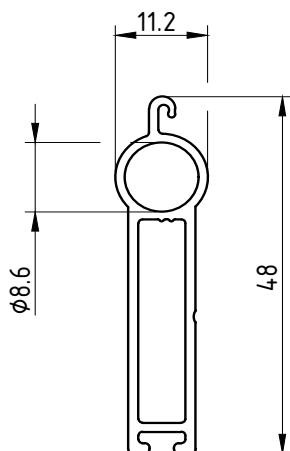

EXL-88055

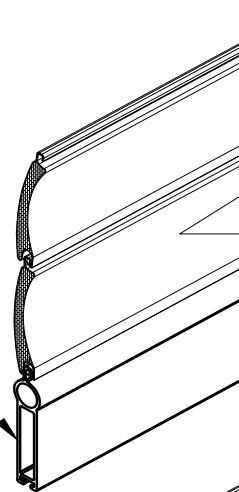

TERM-02
0,300kg/m

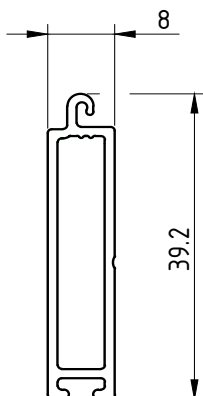

EXL-88999

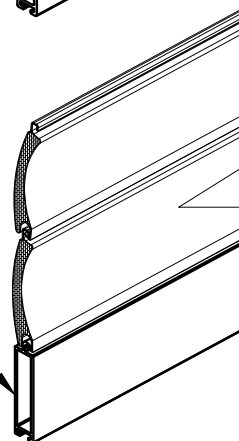

TERM-03
0,382kg/m

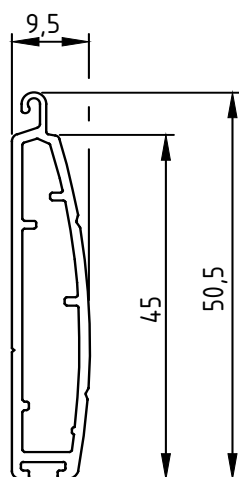

EXL-88340

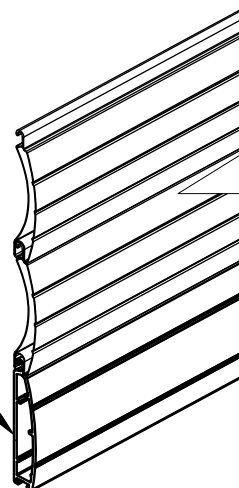

CARACTERÍSTICAS GERAIS:

CÓDIGO	ACABAMENTO
TERM-01BZ	BRONZE ANOD.
TERM-01EB	BRANCO 9003
TERM-01FS	FOSCO ANOD.
TERM-01NT	NATURAL
TERM-01PT	PRETO ANOD.
TERM-02BZ	BRONZE ANOD.
TERM-02EB	BRANCO 9003
TERM-02FS	FOSCO ANOD.
TERM-02NT	NATURAL
TERM-02PT	PRETO ANOD.
TERM-03BZ	BRONZE ANOD.
TERM-03EB	BRANCO 9003
TERM-03FS	FOSCO ANOD.
TERM-03NT	NATURAL
TERM-03PT	PRETO ANOD.

Componentes:

Matéria-prima:

Estrutura

Alumínio

Embalagem

Barras de 6 metros
Pacotes de 10 peças

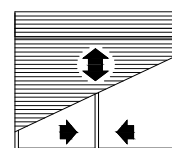

PERSIANAS



ALUMICONTE

COMPONENTES • PERFIS • PERSIANAS

**Completo, dinâmico
e repleto de soluções.**

Acesse:

www.dlumiconte.com.br

