



Aluk 3.2[®]

ALUK 3.2

Grande como as suas ideias.

de ideias.

A gente acredita que o poder das suas ideias é muito maior do que você imagina. É por isso que somos os únicos a atender 3 segmentos diferentes, ampliando assim as possibilidades de fazer parte dos seus projetos.



Componentes



Perfis



Persianas



PERSPECTIVA:
(sem escala)

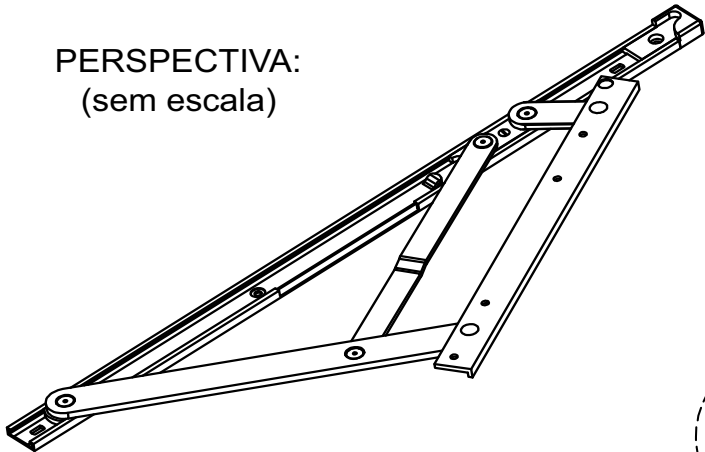

(Cx. 15mm)

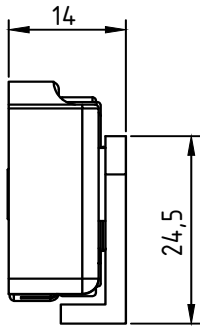

Limitador
de abertura

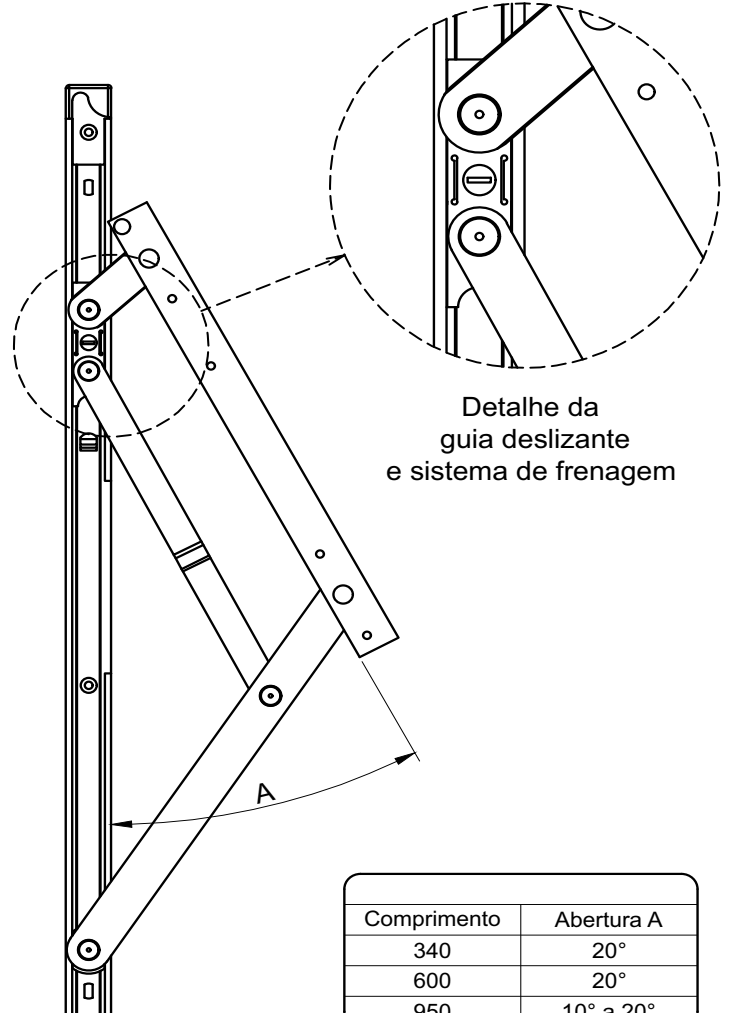

Detalhe da
guia deslizante
e sistema de frenagem

Comprimento	Abertura A
340	20°
600	20°
950	10° a 20°

CARACTERÍSTICAS:

Componentes:	Matéria-prima:
Estrutura	Alumínio
Rebites	Alumínio
Guia deslizante	Poliamida/Aço Inox
Freio	Poliacetral
Buchas	Poliamida
Limitador	Poliamida

Acabamento Anodizado e Pintado	
Preto	Branco

Embalagem	1 par de braços
	Rebites

Acabamento Fosco
sob encomenda

Código Preto	Código Branco	Comprimento (mm)	Altura (mm) Min./Máx.	Largura Máxima (mm)	Peso (Kg) Admissível	Vidro (mm) Esp. Máxima
BRA762	BRA762EB	340	400 a 600	1200	22,0	8
BRA763	BRA763EB	600	700 a 1000	1200	30,0	8
BRA764	BRA764EB	950	1000 a 1200	1200	36,0	8

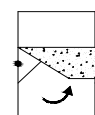

JANELAS
MAXIM-AR

DIMENSÕES:
(escala 2:1)

PERSPECTIVA:
(sem escala)

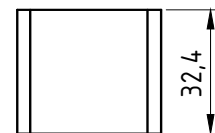
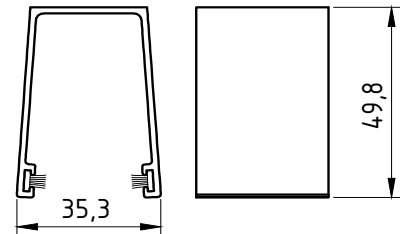
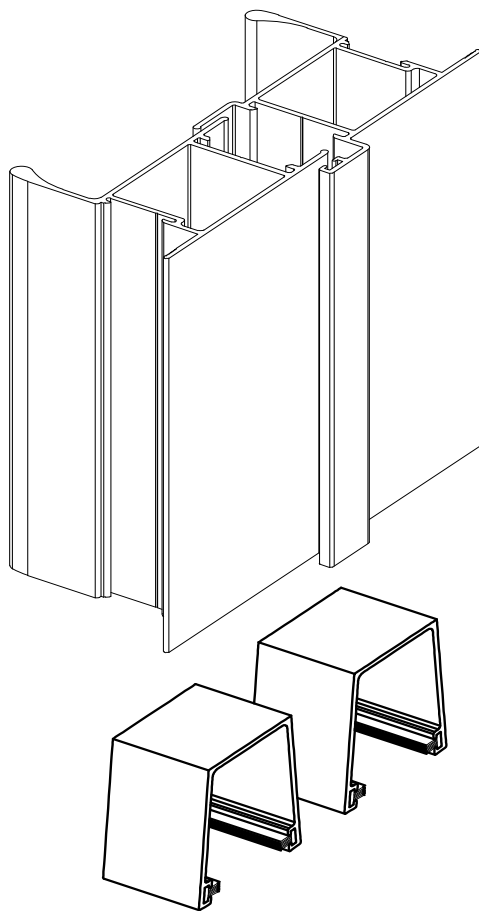

DETALHE DE APLICAÇÃO:
(sem escala)

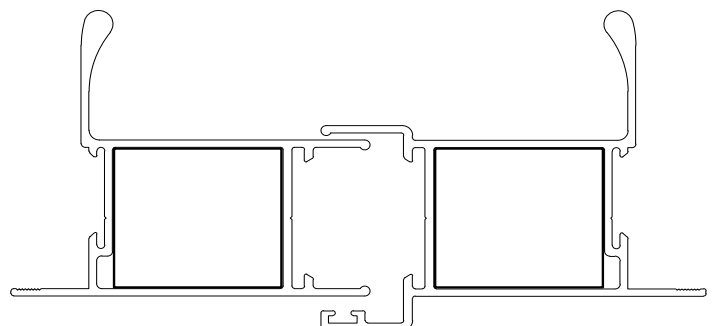

CARACTERÍSTICAS:

Componentes:	Matéria-prima:
Estrutura	Poliamida

Acabamento
Preto

Embalagem	08 Calços
-----------	-----------

CÓDIGO	ACABAMENTO
CAL-929	Preto

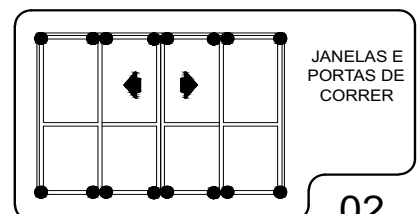

DIMENSÕES:
(escala 2:1)

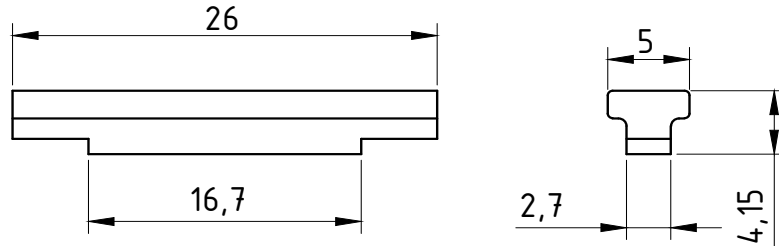

PERSPECTIVA:
(sem escala)

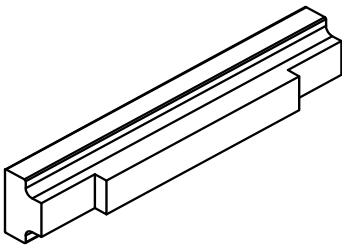

DETALHE DE APLICAÇÃO:
(sem escala)

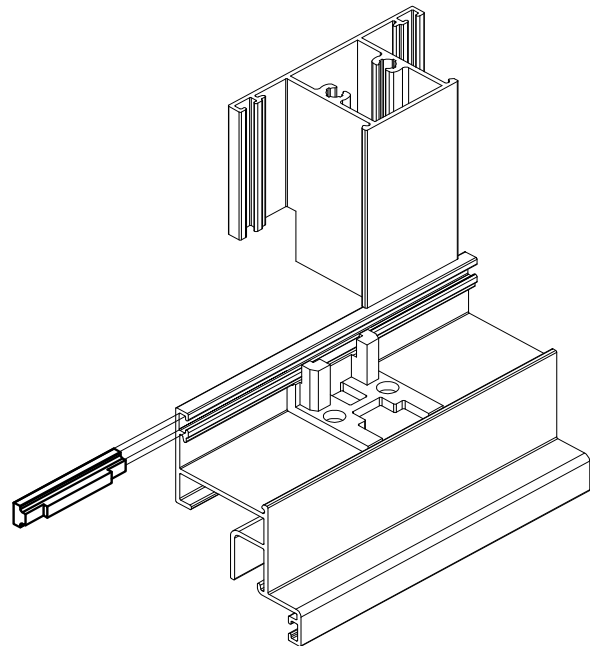

CARACTERÍSTICAS:

Componentes:	Matéria-prima:
Estrutura	Poliamida

Acabamento
Preto

Embalagem	20 Peças
-----------	----------

CÓDIGO	ACABAMENTO
CAL-945	Preto

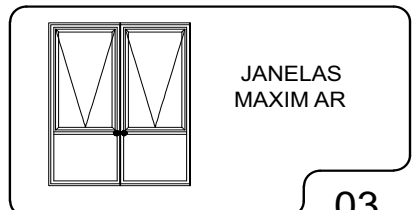

DIMENSÕES: (escala 1:1)

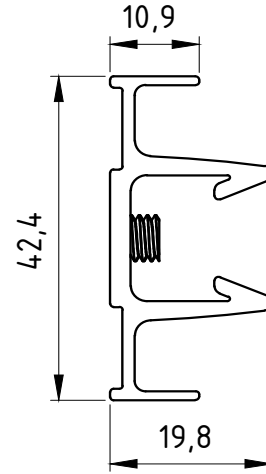
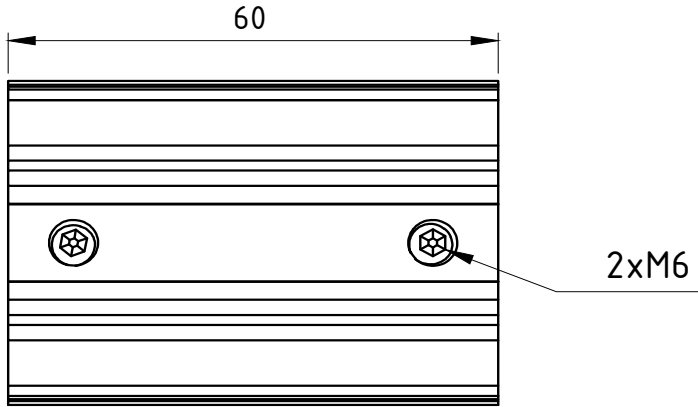

PERSPECTIVA: (sem escala)

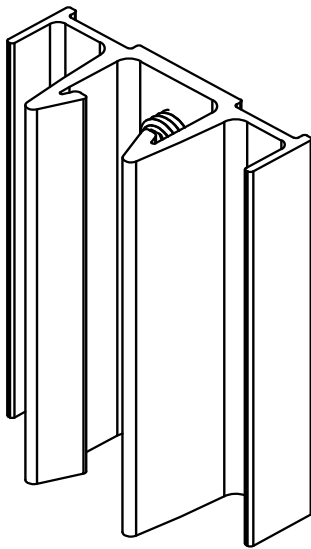

APLICAÇÃO: (sem escala)

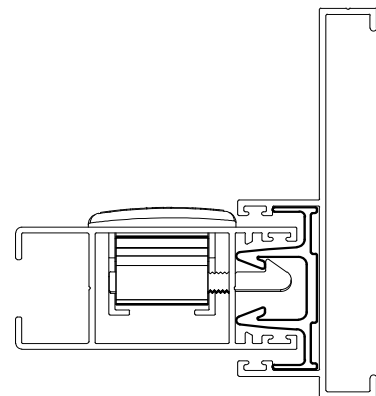

CARACTERÍSTICAS:

Componentes:	Matéria-prima:
Estrutura	Alumínio
Parafusos	Aço Inox

Acabamento	Preto	Branco
------------	-------	--------

Embalagem	10 contrafechos
	20 parafusos

CÓDIGO	ACABAMENTO
CON-320	Preto
CON-320EB	Branco

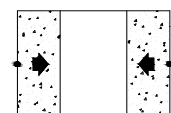

JANELAS
E PORTAS
DE CORRER

DIMENSÕES: (escala 1:1)

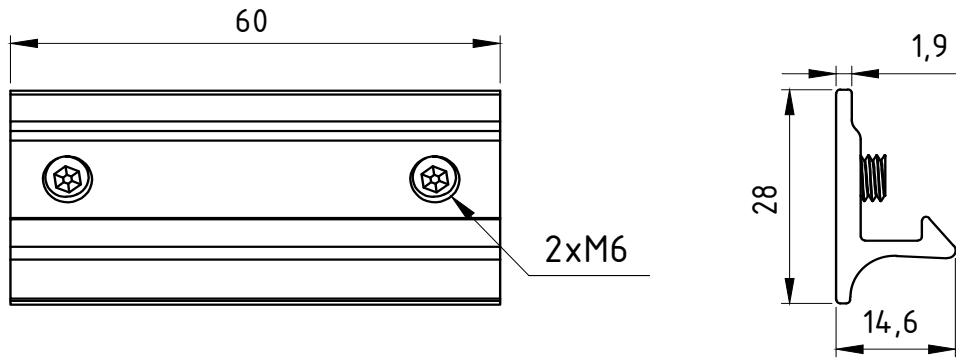

PERSPECTIVA: (sem escala)

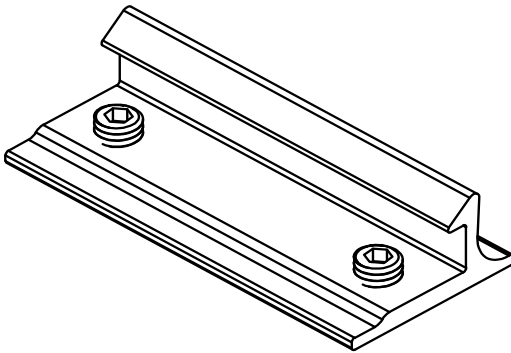

APLICAÇÃO: (sem escala)

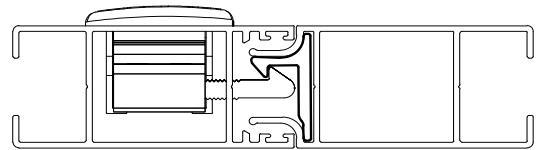

CARACTERÍSTICAS:

Componentes:	Matéria-prima:
Estrutura	Alumínio
Parafusos	Aço Inox

Acabamento	Preto	Branco
------------	-------	--------

Embalagem	10 contrafechos
	20 parafusos

CÓDIGO	ACABAMENTO
CON-321	Preto
CON-321EB	Branco



JANELAS
E PORTAS
DE CORRER



CONTRAFECHO DA FOLHA FIXA

APLICAÇÃO:

ALUK 3.2®

Janeiro/2012

DIMENSÕES:
(escala 1:1)

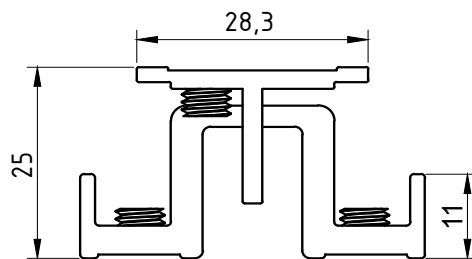

PERSPECTIVA:
(escala 1:1)

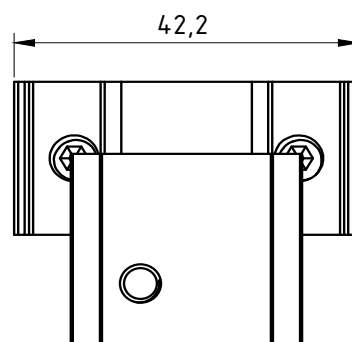
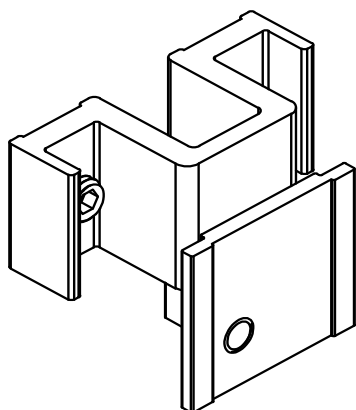

DETALHE DE APLICAÇÃO:
(sem escala)

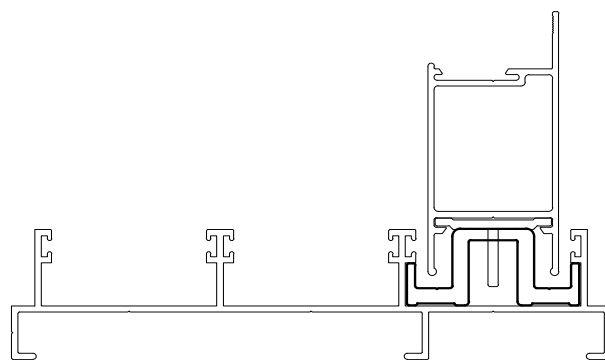

CARACTERÍSTICAS:

Componentes:	Matéria-prima:
Estrutura	Alumínio
Parafusos	Aço Inox

Acabamento
Natural

Embalagem	10 Contrafechos e suportes
	30 Parafusos

CÓDIGO	ACABAMENTO
CON-32	Natural

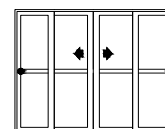

JANELAS
E PORTAS
DE CORRER



CONTRAFECHO LATERAL

APLICAÇÃO:
ALUK 3.2®

Novembro/2008

DIMENSÕES:
(escala 1:1)

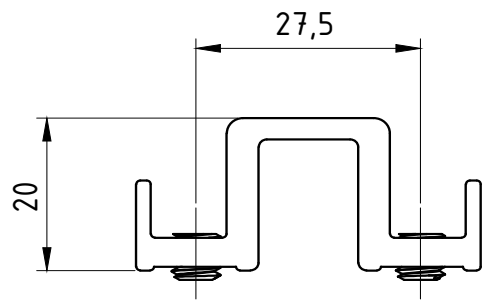

PERSPECTIVA:
(escala 1:1)

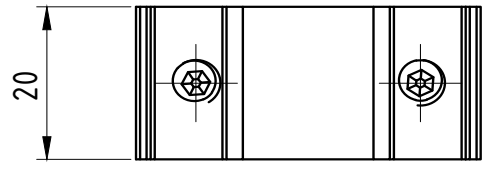
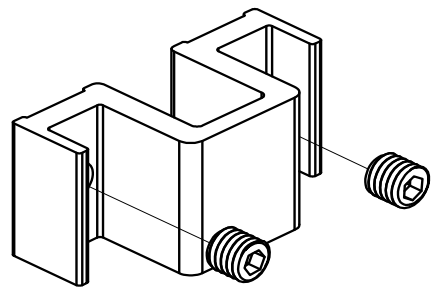

DETALHE DE APLICAÇÃO:
(sem escala)

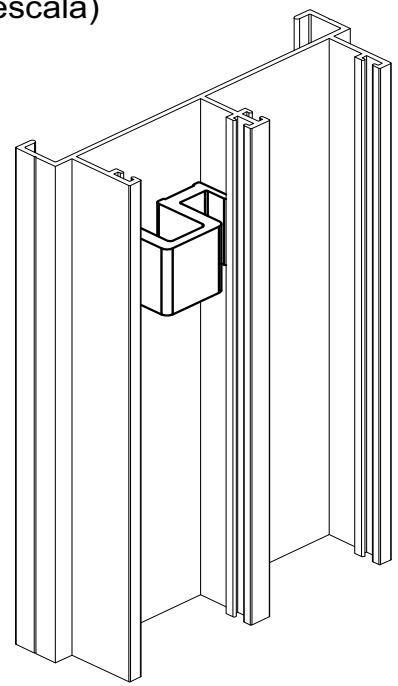

CARACTERÍSTICAS:

Componentes:	Matéria-prima:
Estrutura	Alumínio
Parafusos	Aço Inox

Acabamentos	
Preto	Branco

Embalagem	20 Contrafechos
	40 Parafusos

CÓDIGO	ACABAMENTO
CON-383	Preto
CON-383EB	Branco

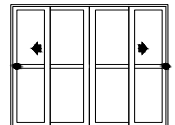

JANELAS
E PORTAS
DE CORRER

DIMENSÕES:
(escala 1:1)

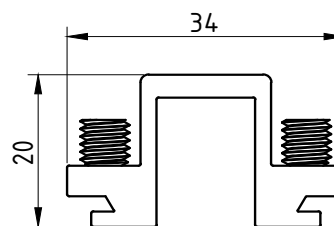

PERSPECTIVA:
(escala 1:1)

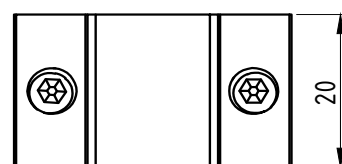
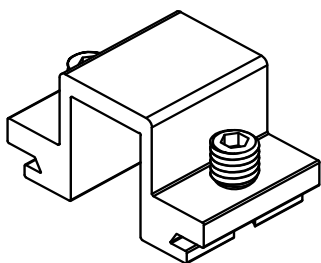

DETALHE DE APLICAÇÃO:
(sem escala)

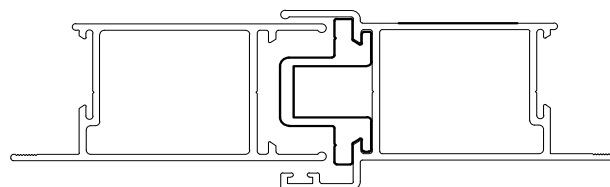

CARACTERÍSTICAS:

Componentes:	Matéria-prima:
Estrutura	Alumínio
Parafusos	Aço Inox

Acabamentos

Preto

Branco

Embalagem

10 Contrafechos

20 Parafusos

CÓDIGO	ACABAMENTO
CON-385	Preto
CON-385EB	Branco

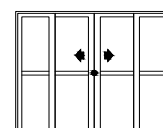

JANELAS
E PORTAS
DE CORRER

DIMENSÕES:
(escala 1:1)

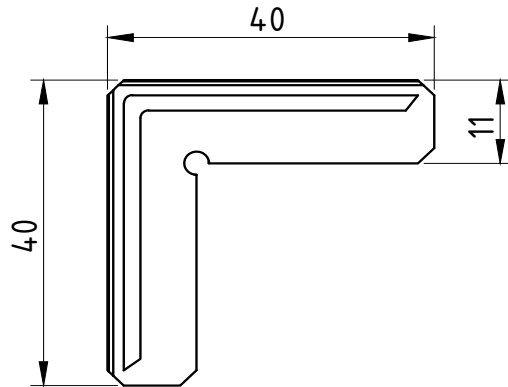

PERSPECTIVA:
(sem escala)

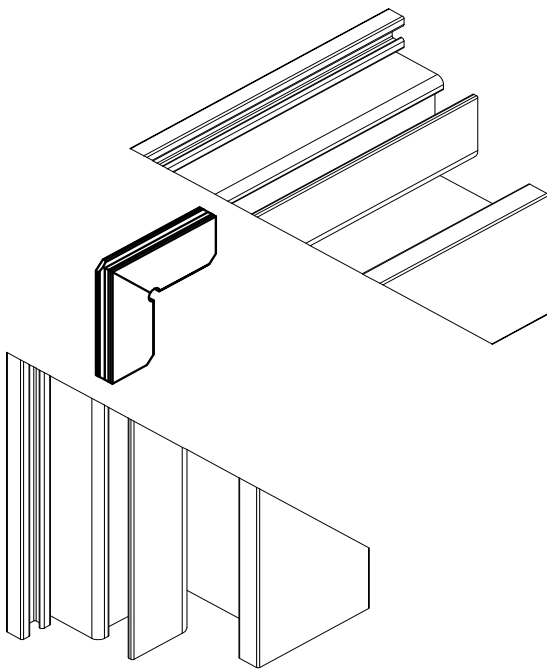

DETALHE DE APLICAÇÃO:
(sem escala)

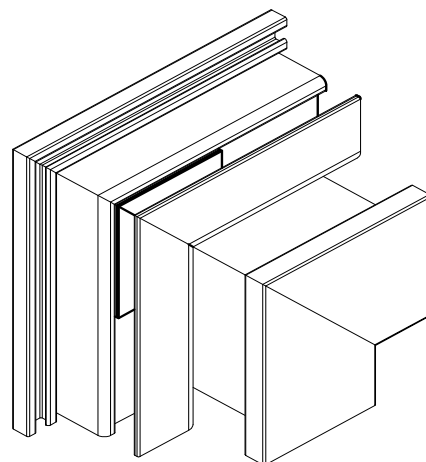

CARACTERÍSTICAS:

Componentes:	Matéria-prima:
Estrutura	Poliamida

Acabamento
Preto

Embalagem	20 Peças
-----------	----------

CÓDIGO	ACABAMENTO
CON-433	Preto

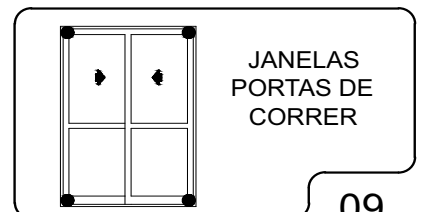

DIMENSÕES:
(escala 1:2)

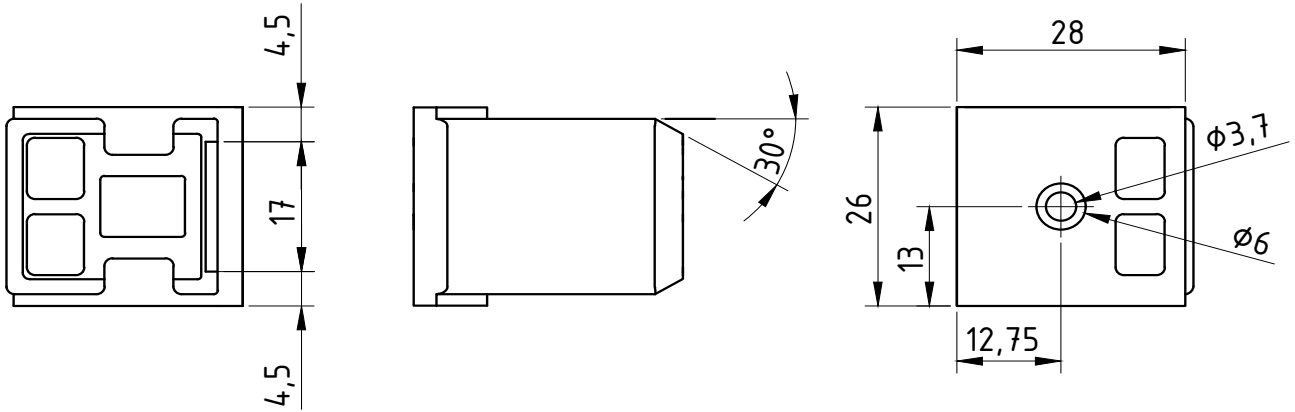

PERSPECTIVA:
(sem escala)

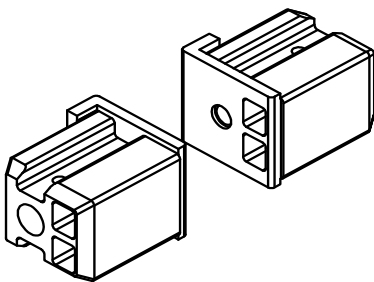

DETALHE DE APLICAÇÃO:
(sem escala)

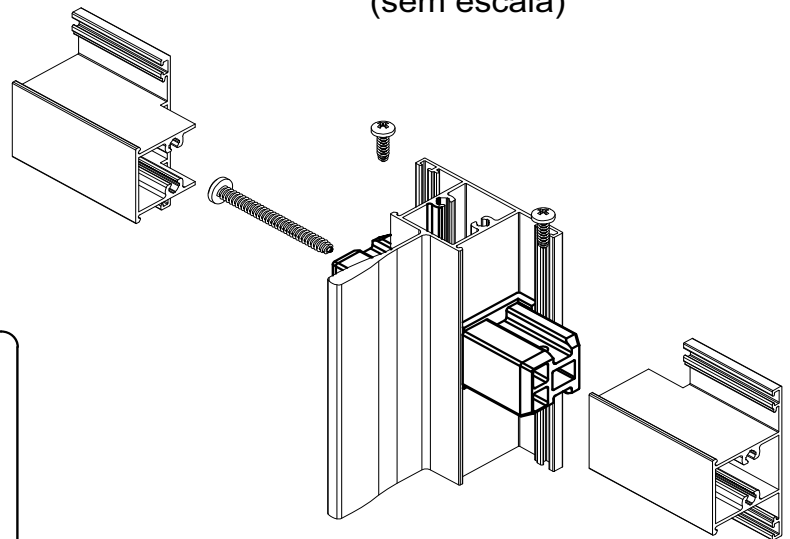

CARACTERÍSTICAS:

Componentes:	Matéria-prima:
Estrutura	Poliamida

Acabamento
Preto

Embalagem	20 Peças
-----------	----------

CÓDIGO	ACABAMENTO
CON-434	Preto

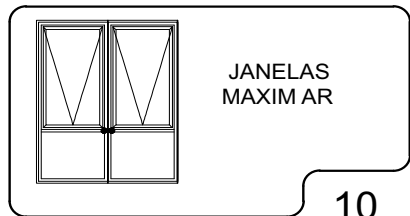

DIMENSÕES:
(escala 1:1)

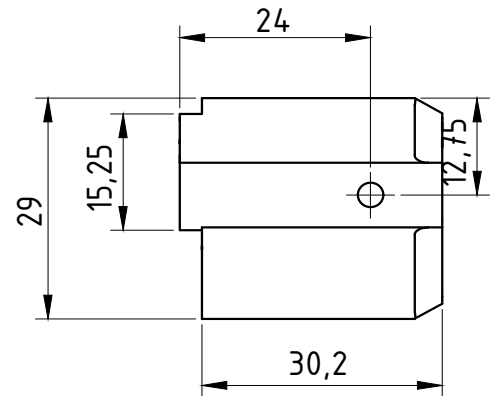
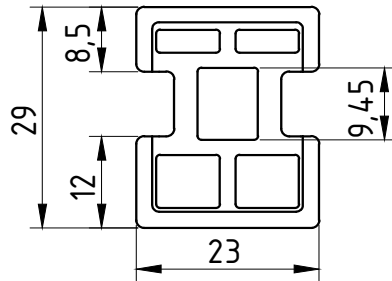
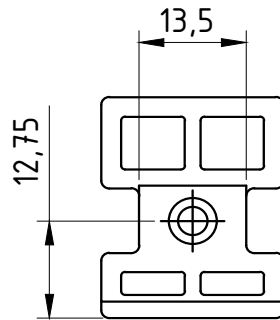

PERSPECTIVA:
(sem escala)

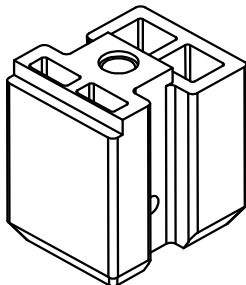
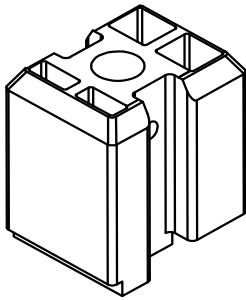

DETALHE DE APLICAÇÃO:
(sem escala)

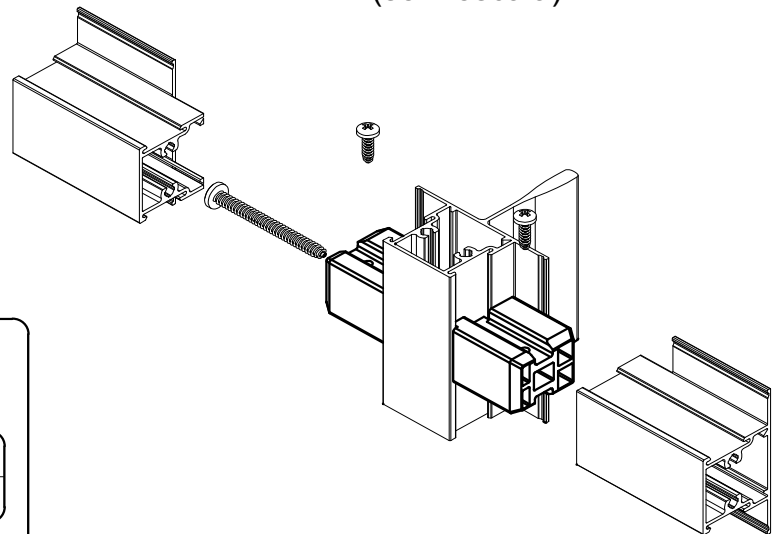

CARACTERÍSTICAS:

Componentes:	Matéria-prima:
Estrutura	Poliamida

Acabamento
Preto

Embalagem	20 Peças
-----------	----------

CÓDIGO	ACABAMENTO
CON-435	Preto

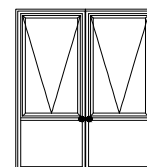

JANELAS
MAXIM AR

DIMENSÕES:
(escala 1:1)

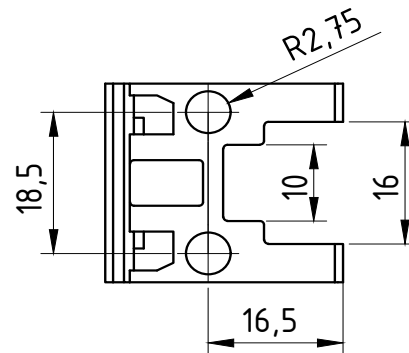
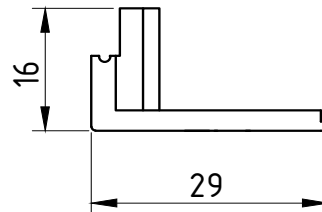
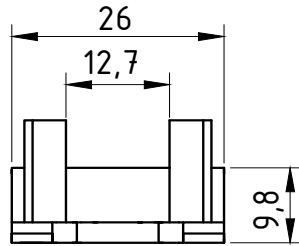

PERSPECTIVA:
(sem escala)

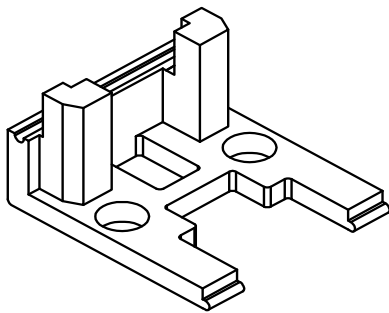

DETALHE DE APLICAÇÃO:
(sem escala)

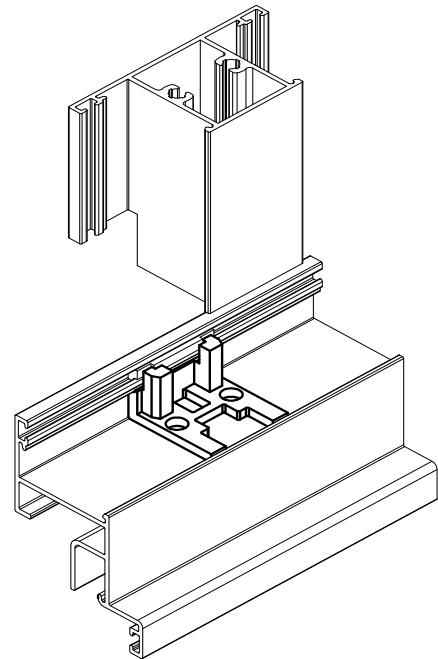

CARACTERÍSTICAS:

Componentes:	Matéria-prima:
Estrutura	Poliamida

Acabamento
Preto

Embalagem	20 Peças
-----------	----------

CÓDIGO	ACABAMENTO
CON-436	Preto

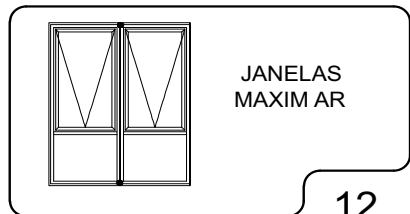

DIMENSÕES:
(escala 1:1)

PERSPECTIVA:
(sem escala)

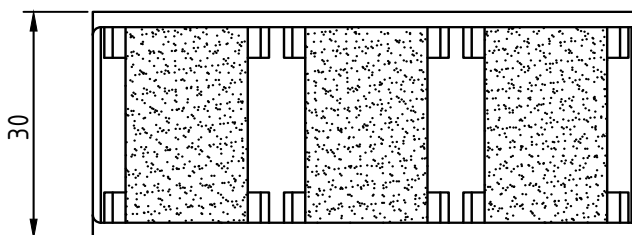
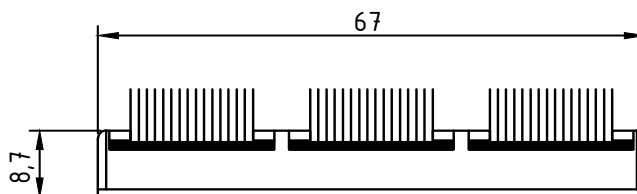
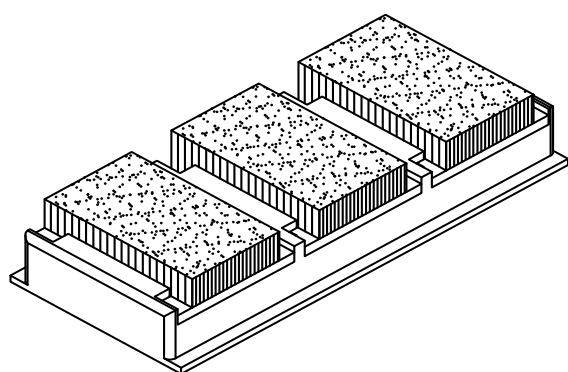

DETALHES DE APLICAÇÃO:
(sem escala)

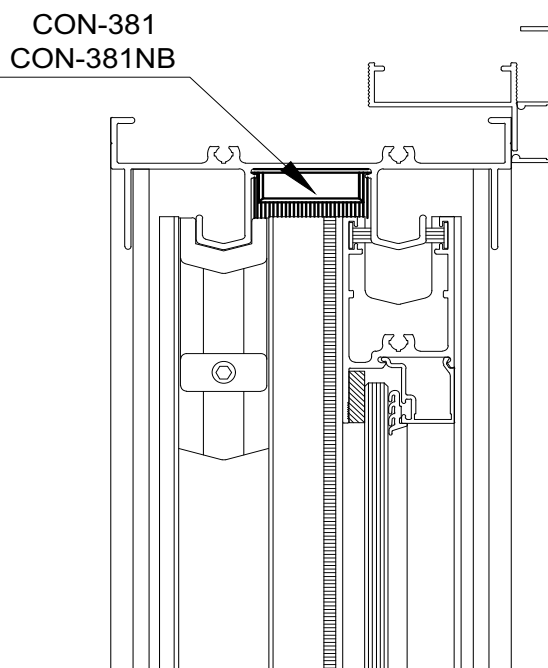

CARACTERÍSTICAS:

Componentes:	Matéria-prima:
Estrutura	Poliamida
Fita Vedadora	Polipropileno

Acabamentos	
Preto	Branco

Embalagem	100 Peças
-----------	-----------

CÓDIGO	ACABAMENTO
CON-381	Preto
CON-381NB	Branco

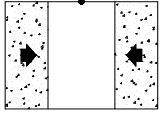

JANELAS E PORTAS DE CORRER

Julho/2008

DIMENSÕES:
(escala 1:2)

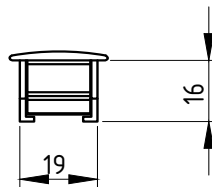

USINAGEM:
(escala 1:2)

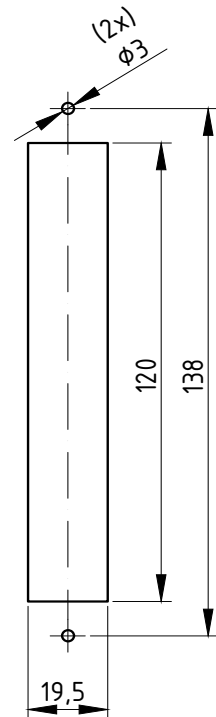

PERSPECTIVA:
(sem escala)

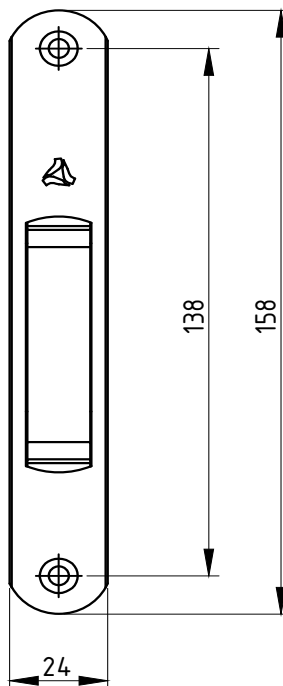
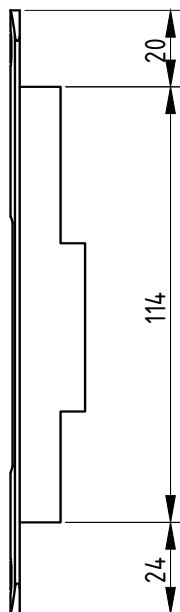
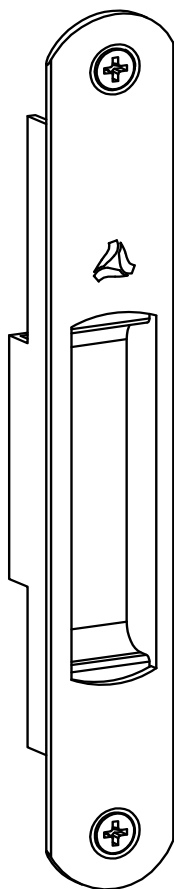

DETALHE DE MONTAGEM
(Sem Escala)

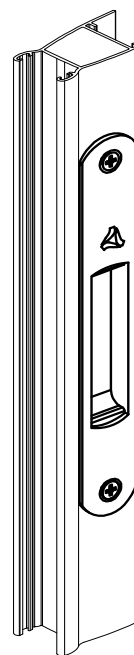

CARACTERÍSTICAS:

Componentes:	Matéria-prima:
Estrutura	Alumínio
Parafusos	Aço Inox

Acabamento Anodizado e Pintado		
Preto	Fosco	Branco

Embalagem	20 Conchas Cegas
	40 Parafusos

CÓDIGO	ACABAMENTO
CON-448	Preto
CON-4480	Fosco
CON-448EB	Branco



JANELAS
E PORTAS
DE CORRER

Julho/2008

PERSPECTIVA:
(sem escala)

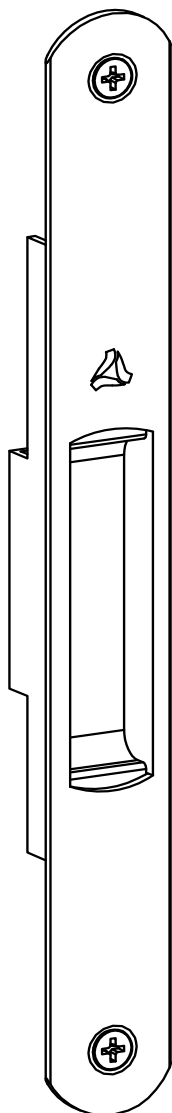

DIMENSÕES:
(escala 1:2)

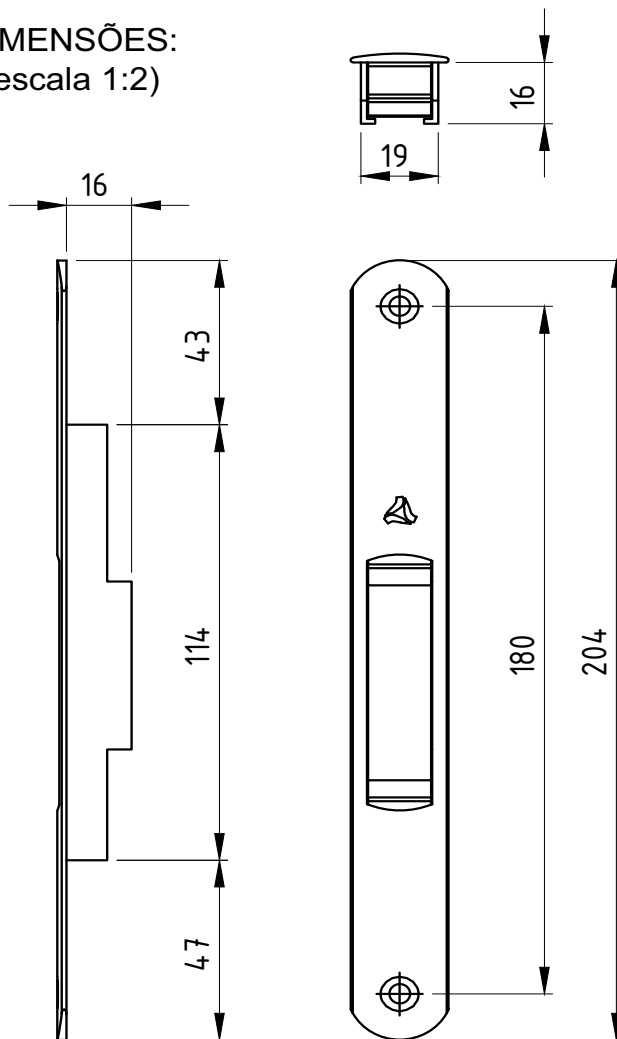

USINAGEM:
(escala 1:2)

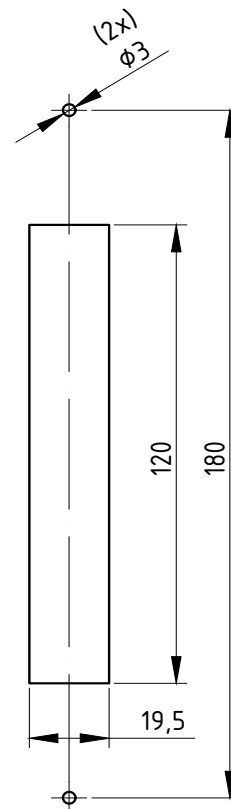

DETALHE DE MONTAGEM
(Sem Escala)

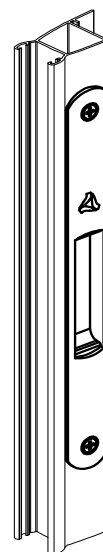

CARACTERÍSTICAS:

Componentes:	Matéria-prima:
Estrutura	Alumínio
Parafusos	Aço Inox

Acabamento Anodizado e Pintado		
Preto	Fosco	Branco

Embalagem	20 Conchas Cegas
	40 Parafusos

CÓDIGO	ACABAMENTO
CON-449	Preto
CON-4490	Fosco
CON-449EB	Branco



JANELAS
E PORTAS
DE CORRER

PERSPECTIVA:
(sem escala)

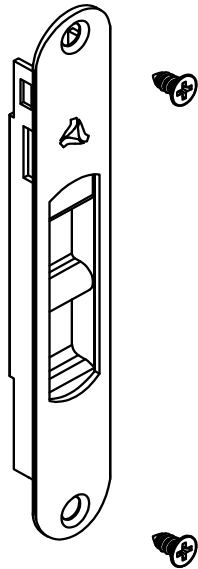

DIMENSÕES:
(escala 1:2)

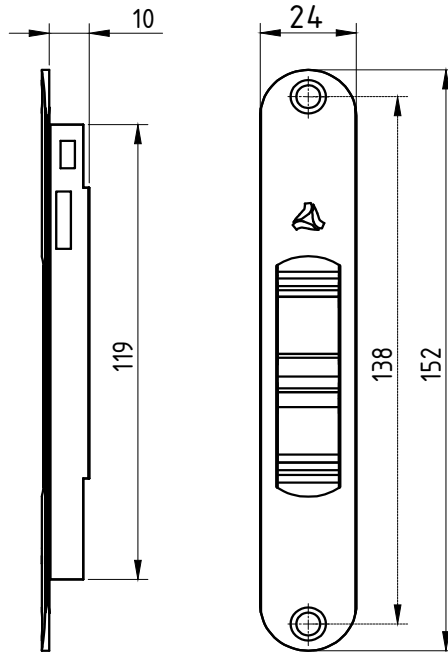

USINAGEM:
(escala 1:2)

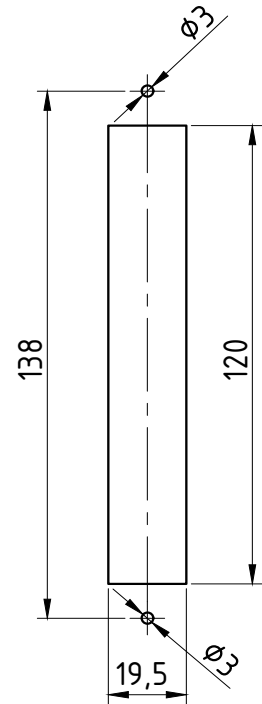

DETALHE DE APLICAÇÃO:
(sem escala)

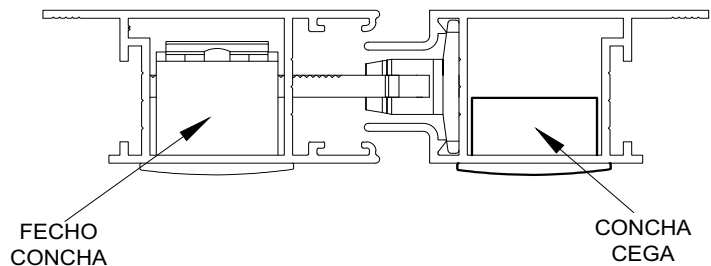

CARACTERÍSTICAS:

Componentes:	Matéria-prima:
Estrutura	Alumínio
Parafusos	Aço Inox

Acabamento Anodizado e Pintado		
Preto	Fosco	Branco

Embalagem	20 Conchas cegas
	40 Parafusos

CÓDIGO	ACABAMENTO
CON-200	Preto
CON-2000	Fosco
CON-200EB	Branco



JANELAS
E PORTAS
DE CORRER

PERSPECTIVA:
(sem escala)

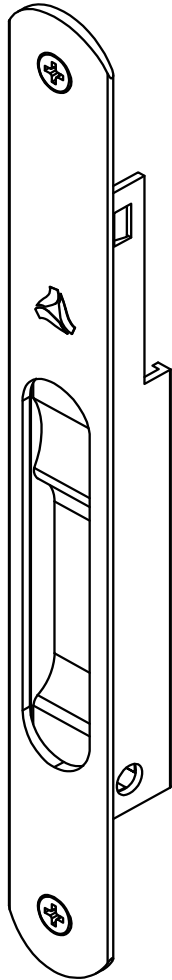

USINAGEM:
(escala 1:2)

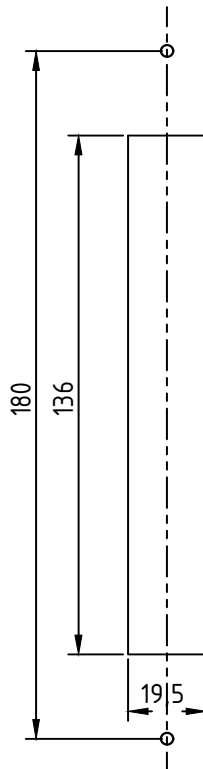

(escala 1:2)

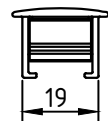
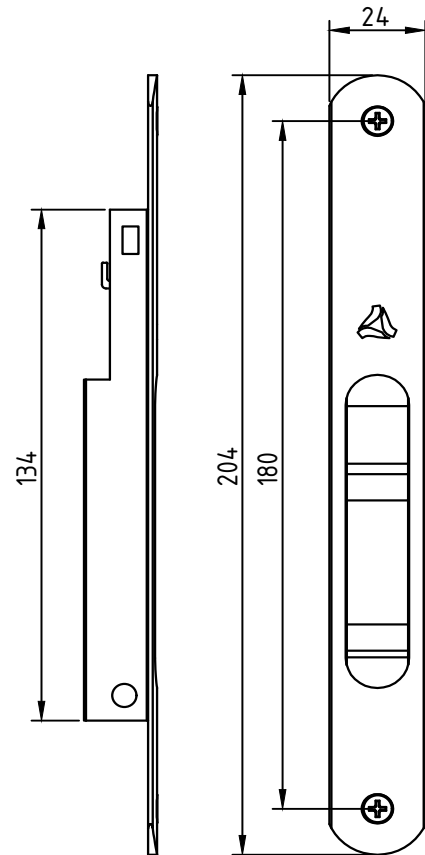

Componentes:	Matéria-prima:
Estrutura	Alumínio
Eixo de centro	Alumínio
Parafusos	Aço Inox

Acabamento Anodizado e Pintado

Preto Fosco Branco Bronze

Embalagem

20 Conchas cegas

40 Parafusos

CÓDIGO	ACABAMENTO
CON-0155PT	Preto
CON-0155FS	Fosco
CON-0155BC	Branco
CON-0155BR	Bronze

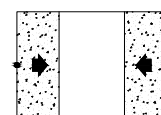

JANELAS
E PORTAS
DE CORRER

PERSPECTIVA:
(sem escala)

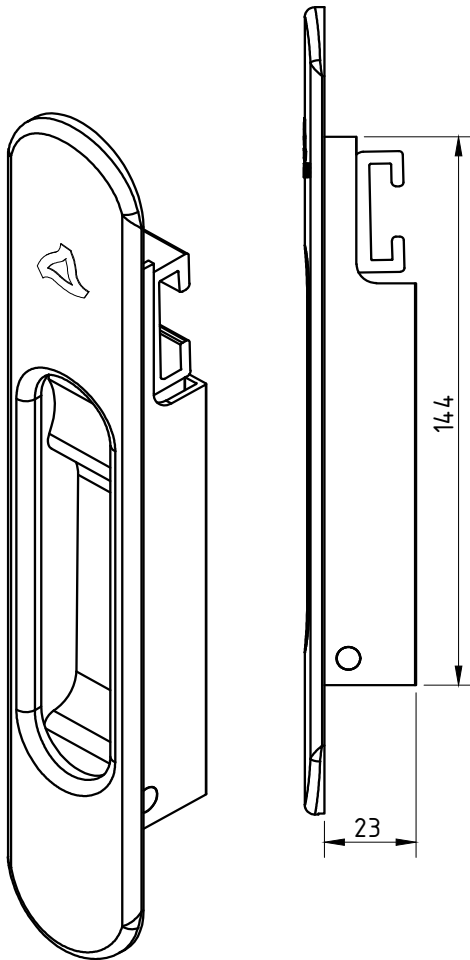

(escala 1:2)

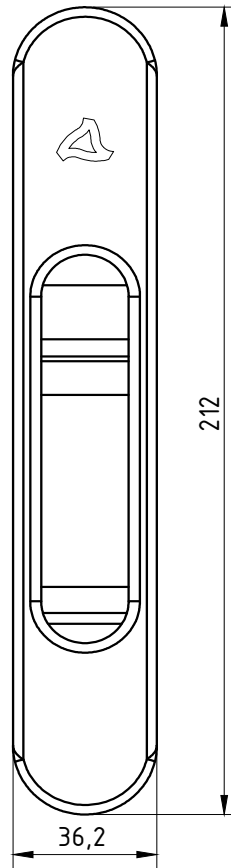

USINAGEM

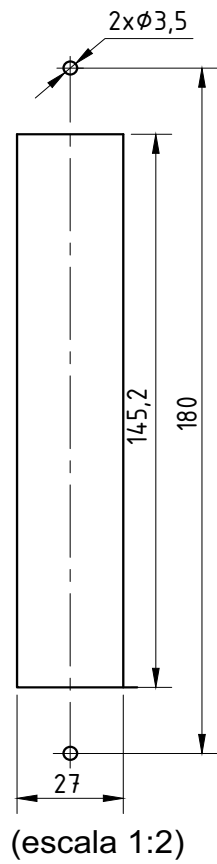

(escala 1:2)

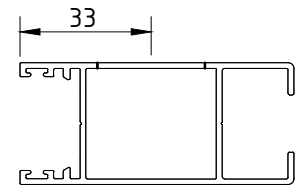

(escala 1:2)

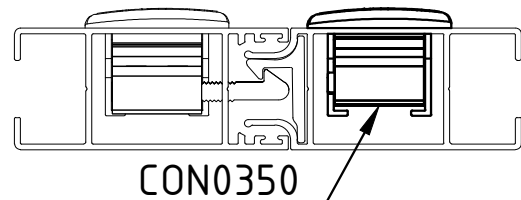

Componentes:	Matéria-prima:
Estrutura	Alumínio
Parafusos	Aço Inox
Eixo de centro	Alumínio
Espelho	Poliamida

Acabamento Pintado	
Preto	Branco

Embalagem	10 Conchas cegas
	10 Espelhos
	20 Parafusos

CÓDIGO	ACABAMENTO
CON0350PT	Preto
CON0350BC	Branco



JANELAS
E PORTAS
DE CORRER

DIMENSÕES:
(escala 1:2)

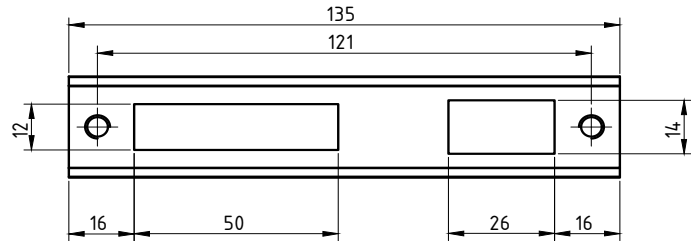
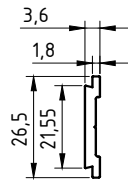

PERSPECTIVA:
(sem escala)



DETALHE DE APLICAÇÃO:
(Sem escala)

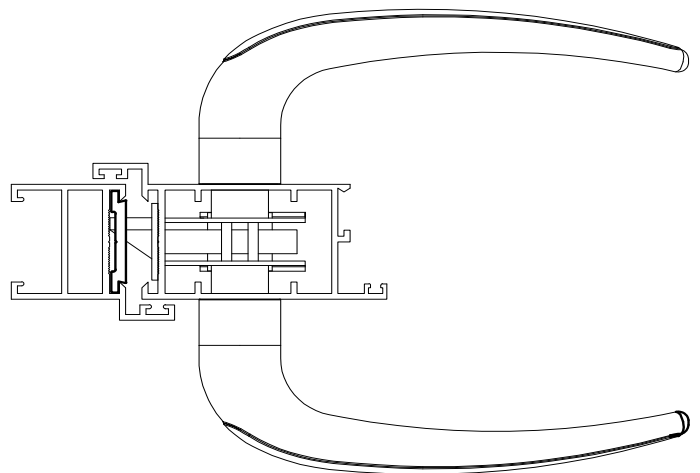

CARACTERÍSTICAS:

Componentes:	Matéria-prima:
Estrutura	Alumínio
Parafuso	Aço inox

Acabamentos		
Preto	Branco	Fosco

Embalagem	01 Contra testa
	02 Parafusos

CÓDIGO	ACABAMENTO
CON-386	Preto
CON-386EB	Branco
CON-386FS	Fosco

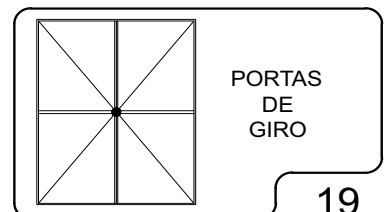

PERSPECTIVA
(sem escala)

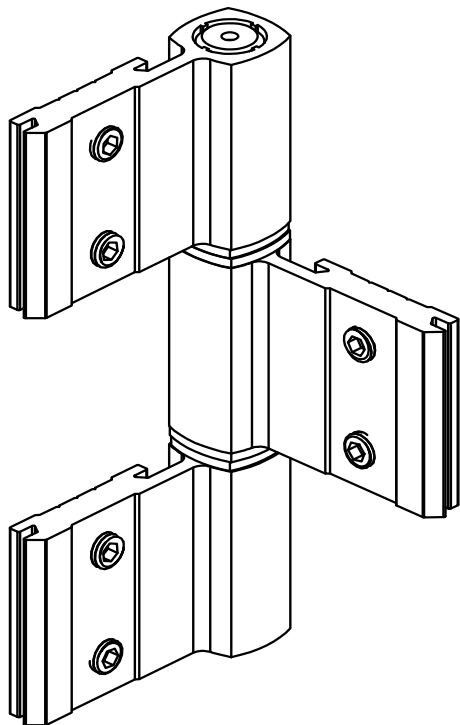

DIMENSÕES:
(escala 1:2)

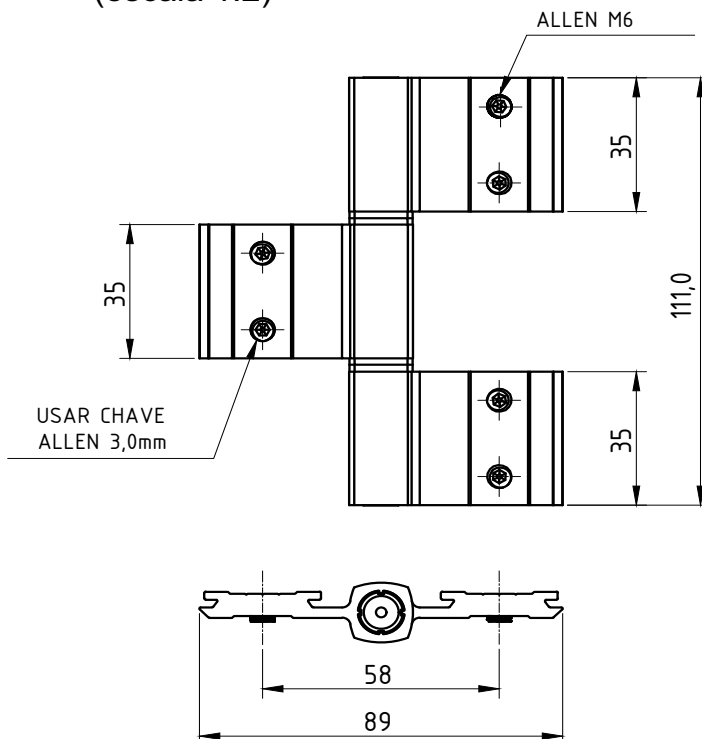

DETALHE DE APLICAÇÃO:
(sem escala)

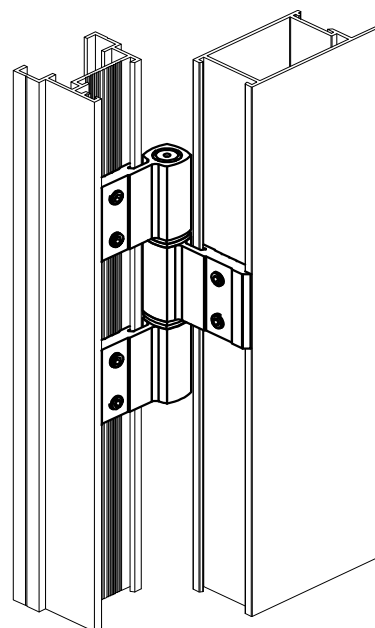

OBSERVAÇÃO:
Três dobradiças por folha
Carga máxima 60 kg
Dimensões máximas 900 x 2100 mm

CARACTERÍSTICAS:

Componentes:	Matéria-prima:
Abas	Alumínio
Eixo central	Alumínio
Buchas	Poliamida
Parafusos	Aço Inox

Acabamento Anodizado e Pintado

Preto Fosco Branco

Embalagem 30 Dobradiças
180 Parafusos

CÓDIGO	ACABAMENTO
DOB - 828	Preto
DOB - 829	Fosco
DOB - 828EB	Branco



PORTAS DE GIRO

PERSPECTIVA:
(sem escala)

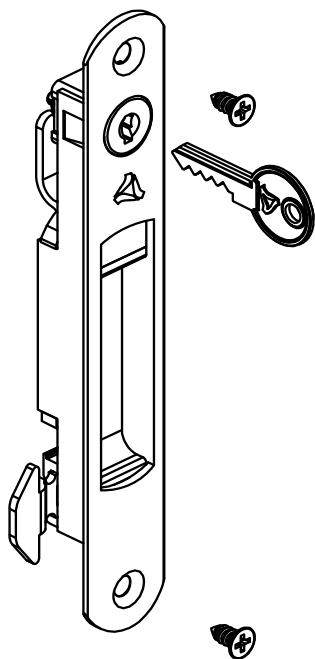

DIMENSÕES:
(escala 1:2)

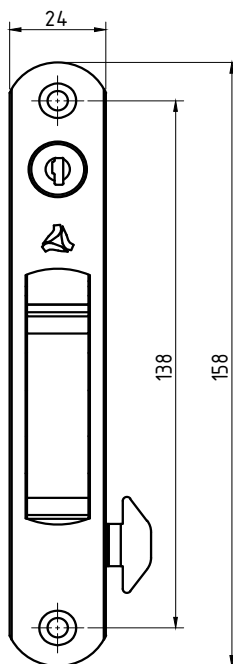
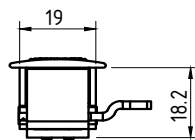
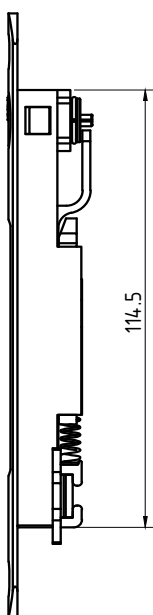

USINAGEM:
(escala 1:2)

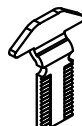
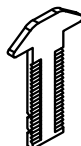
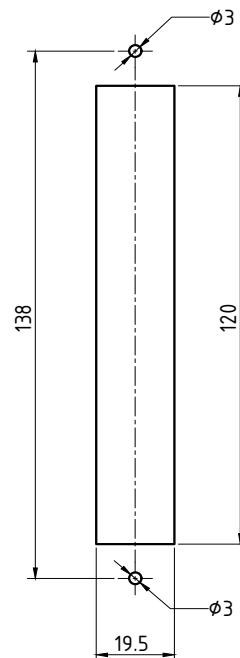

ATENÇÃO:

VERIFICAR QUAL O TIPO DE
TRAVA IDEAL PARA O PROJETO

CÓD: LIN-04 Cód: LIN-03

CARACTERÍSTICAS:

Componentes:	Matéria-prima:
Estrutura	Alumínio
Lingueta	Aço Inox
Parafusos	Aço Inox
Limitador	Poliamida
Acabamentos	Poliamida
Chave	Latão
Cilindro	Zamac

Acabamento Anodizado e Pintado

Preto Fosco Branco

Embalagem

20 Fechos
20 Linguetas
40 Parafusos

DETALHE DE APLICAÇÃO: (sem escala)

CÓD: LIN-04

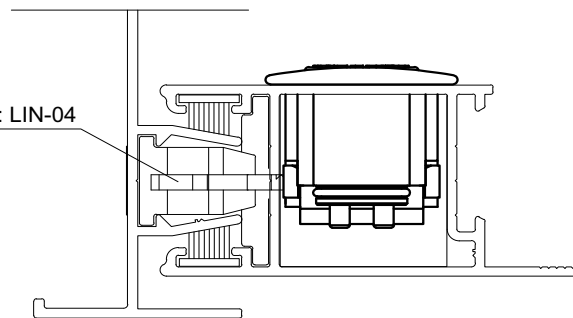

CÓDIGO	ACABAMENTO
FEC-1035 (Manual)	Preto
FEC-10350 (Manual)	Fosco
FEC-1035EB (Manual)	Branco
FEC-1036 (Autom.)	Preto
FEC-10360 (Autom.)	Fosco
FEC-1036EB (Autom.)	Branco

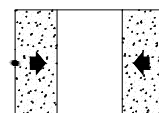

JANELAS
E PORTAS
DE CORRER

PERSPECTIVA:
(sem escala)

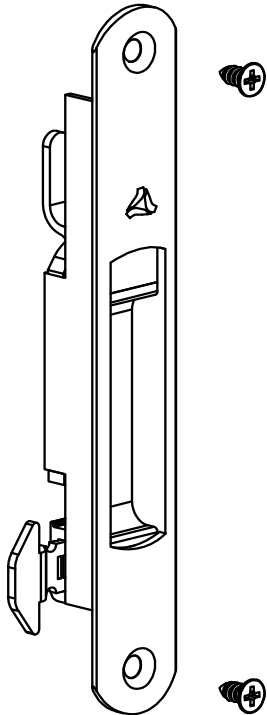

(escala 1:2)

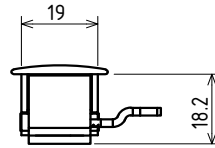
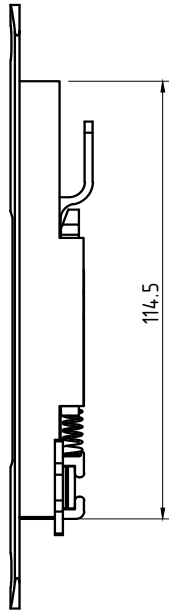

USINAGEM:
(escala 1:2)

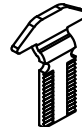
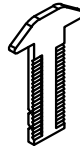
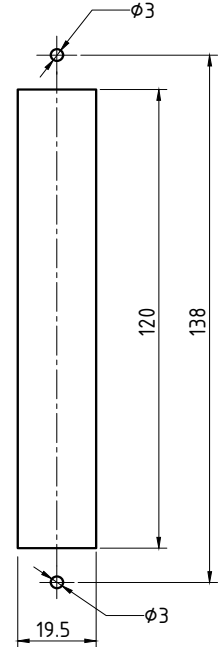
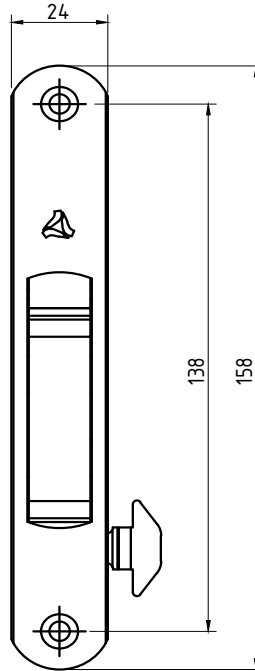

VERIFICAR QUAL O TIPO DE TRAVA IDEAL PARA O PROJETO

(sem escala)

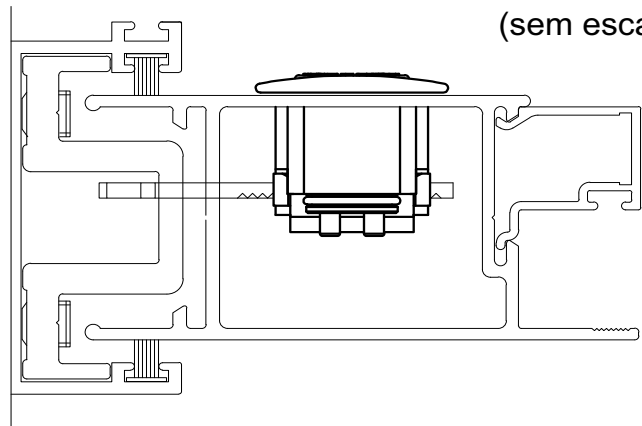

Componentes:

Matéria-prima:

Estrutura

Alumínio

Lingueta

Aço Inox

Parafusos

Aço Inox

Limitador

Poliamida

Acabamentos

Poliamida

Acabamento Anodizado e Pintado

Preto

Fosco

Branco

Embalagem

20 Fechos

20 Linguetas

40 Parafusos

ACABAMENTO

FEC-1037 (Manual)

Preto

FEC-10370 (Manual)

Fosco

FEC-1037EB (Manual)

Branco

FEC-1038 (Autom.)

Preto

FEC-10380 (Autom.)

Fosco

FEC-1038EB (Autom.)

Branco

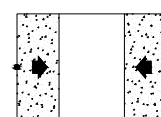

JANELAS
E PORTAS
DE CORRER

PERSPECTIVA:
(sem escala)

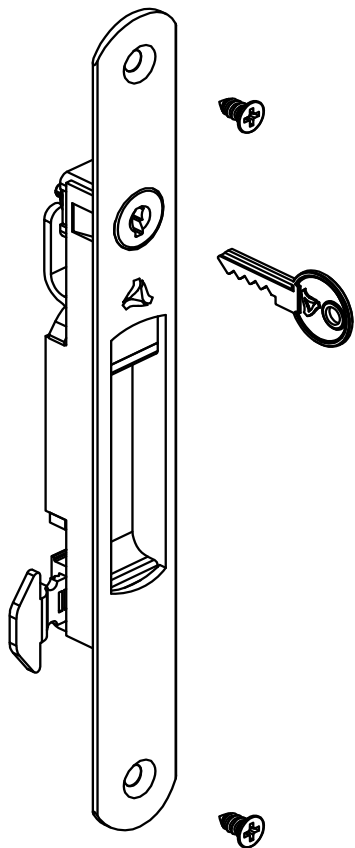

(escala 1:2)

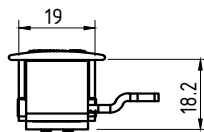
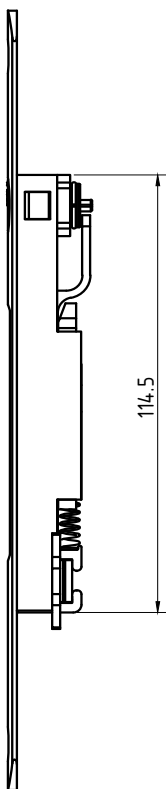

USINAGEM:
(escala 1:2)

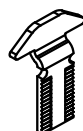
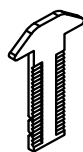
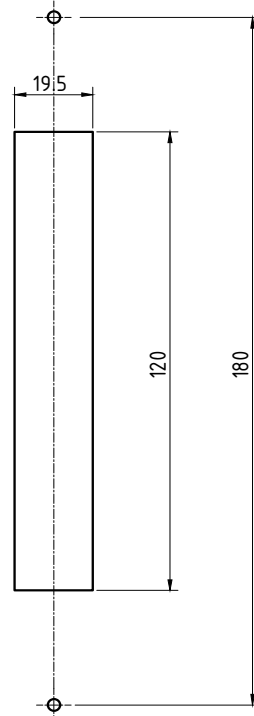
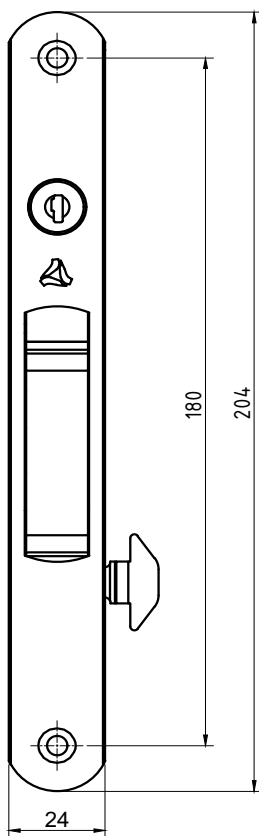

VERIFICAR QUAL O TIPO DE TRAVA IDEAL PARA O PROJETO

Componentes:

Matéria-prima:

Estrutura

Alumínio

Lingueta

Aço Inox

Parafusos

Aço Inox

Limitador

Poliamida

Acabamentos

Poliamida

Chave

Latão

Cilindro

Zamac

Acabamento Anodizado e Pintado

Preto

Fosco

Branco

Embalagem

20 Fechos

20 Linguetas

40 Parafusos

(sem escala)

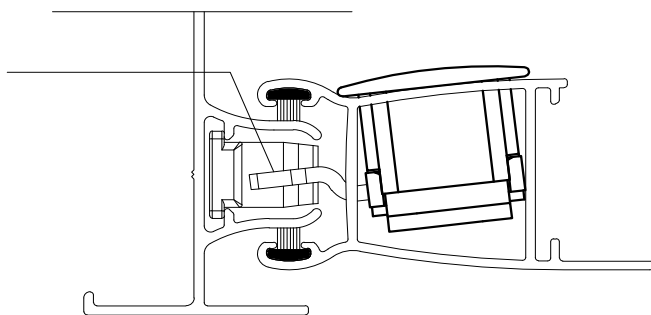

CÓDIGO

ACABAMENTO

FEC-1039 (Manual)

Preto

FEC-10390 (Manual)

Fosco

FEC-1039EB (Manual)

Branco

FEC-1040 (Autom.)

Preto

FEC-10400 (Autom.)

Fosco

FEC-1040EB (Autom.)

Branco

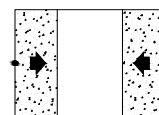

JANELAS
E PORTAS
DE CORRER

PERSPECTIVA:
(sem escala)

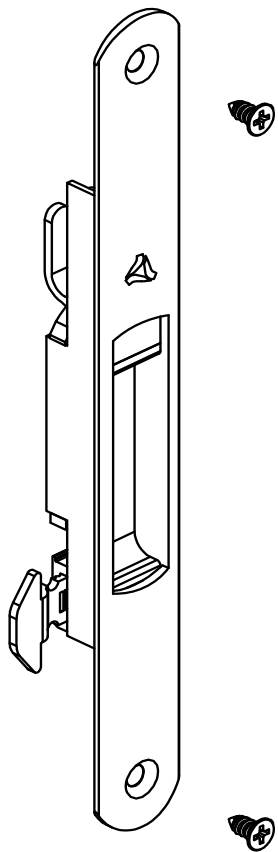

(escala 1:2)

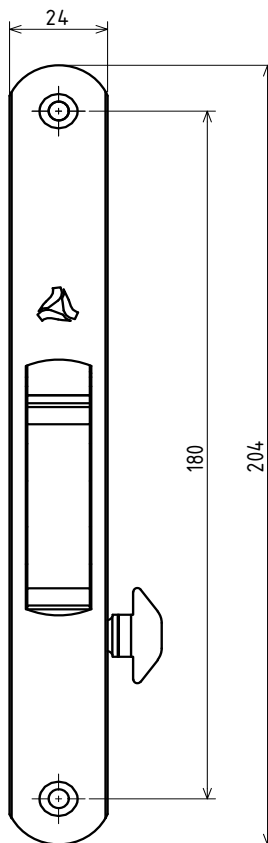
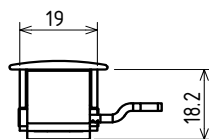
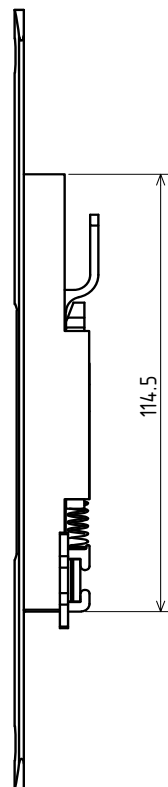

USINAGEM:
(escala 1:2)

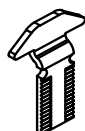
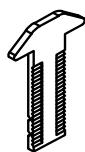
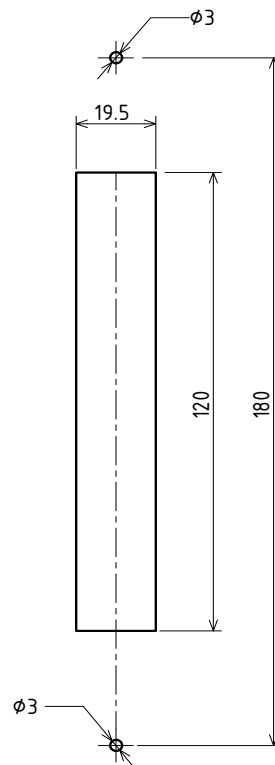

VERIFICAR QUAL O TIPO DE TRAVA IDEAL PARA O PROJETO

(sem escala)

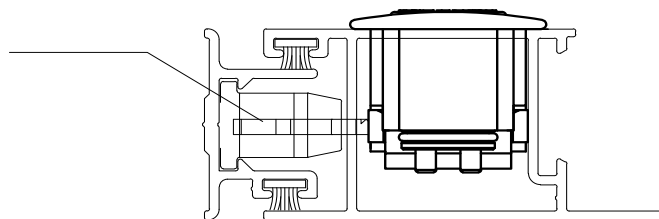

Componentes:	Matéria-prima:
Estrutura	Alumínio
Lingueta	Aço Inox
Parafusos	Aço Inox
Limitador	Poliamida
Acabamentos	Poliamida

Acabamento Anodizado e Pintado		
Preto	Fosco	Branco

Embalagem	20 Fechos
	20 Linguetas
	40 Parafusos

CÓDIGO	ACABAMENTO
FEC-1041 (Manual)	Preto
FEC-10410 (Manual)	Fosco
FEC-1041EB (Manual)	Branco
FEC-1042 (Autom.)	Preto
FEC-10420 (Autom.)	Fosco
FEC-1042EB (Autom.)	Branco

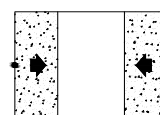

JANELAS
E PORTAS
DE CORRER

PERSPECTIVA:
(sem escala)

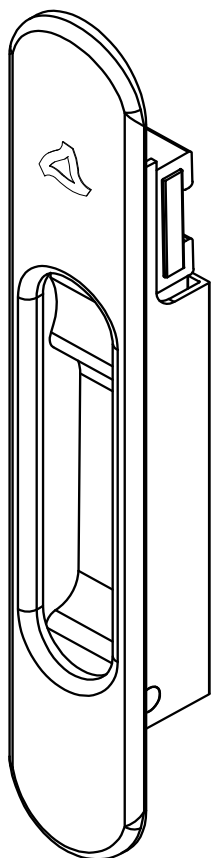

(escala 1:2)

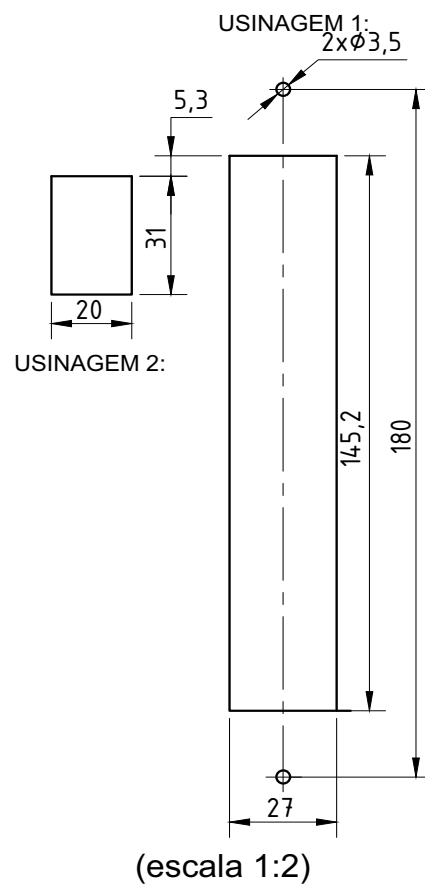
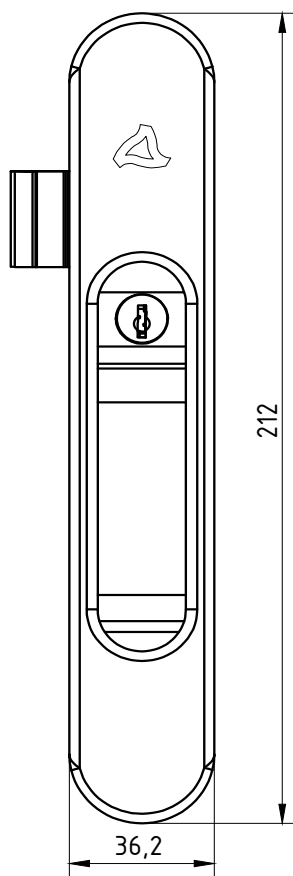
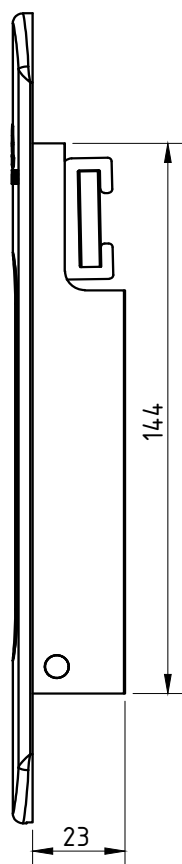

(escala 1:2)

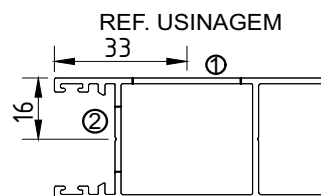

(escala 1:2)

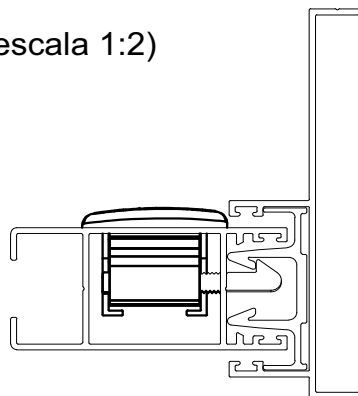

Componentes:	Matéria-prima:
Estrutura	Alumínio
Lingueta	Alumínio
Parafusos	Aço Inox
Mola	Aço Mola
Eixo de centro	Alumínio
Espelho	Poliamida

Acabamento Pintado	
Preto	Branco

Embalagem	10 Fechos
	10 Linguetas
	10 Espelhos
	20 Parafusos

CÓDIGO	ACABAMENTO
FEC-0320PT	Preto - s/chave
FEC-0320BC	Branco - s/chave
FEC-0321PT	Preto - c/chave
FEC-0321BC	Branco - c/chave

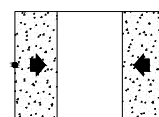

JANELAS
E PORTAS
DE CORRER

PERSPECTIVA:
(sem escala)

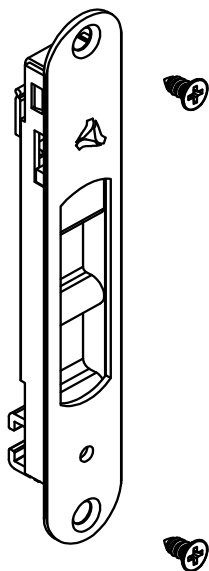

DIMENSÕES:
(escala 1:2)

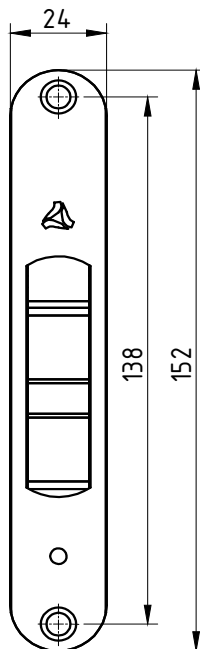
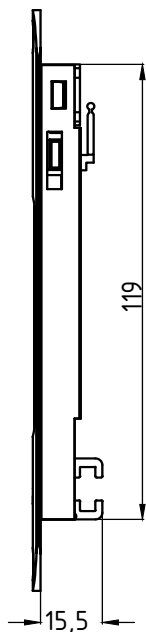

USINAGEM:
(escala 1:2)

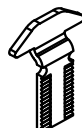
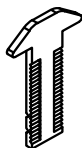
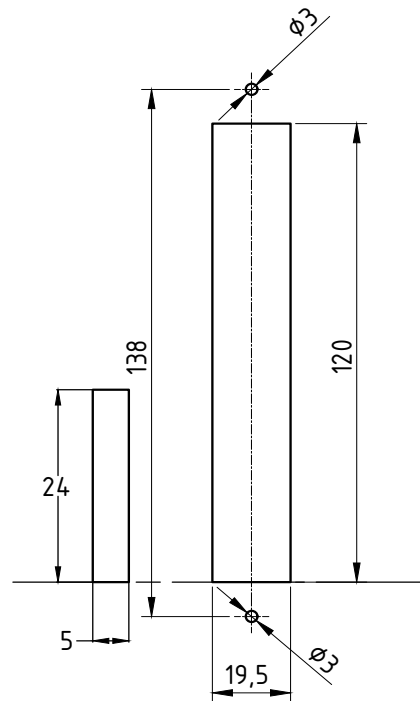

ATENÇÃO:

VERIFICAR QUAL O TIPO DE
TRAVA IDEAL PARA O PROJETO

CÓD: LIN-04 CÓD: LIN-03

DETALHE DE APLICAÇÃO:
(sem escala)

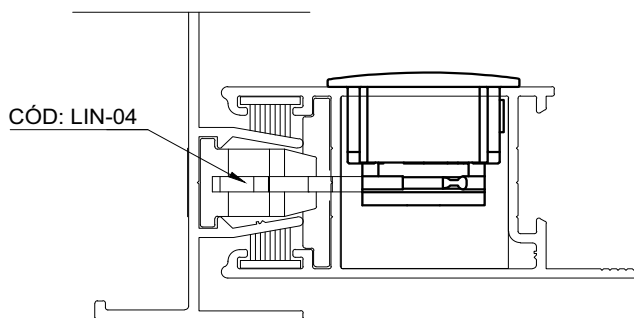

CARACTERÍSTICAS:

Componentes:	Matéria-prima:
Estrutura	Alumínio
Lingueta	Aço Inox
Parafusos	Aço Inox
Limitador	Poliamida

Acabamento Anodizado e Pintado

Preto

Fosco

Branco

Embalagem

20 Fechos

20 Linguetas

40 Parafusos

CÓDIGO	ACABAMENTO
FEC-200 (Manual)	Preto
FEC-2000 (Manual)	Fosco
FEC-200EB (Manual)	Branco
FEC-201 (Autom.)	Preto
FEC-2010 (Autom.)	Fosco
FEC-201EB (Autom.)	Branco

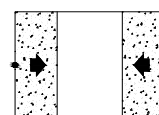

JANELAS
E PORTAS
DE CORRER

PERSPECTIVA:
(sem escala)

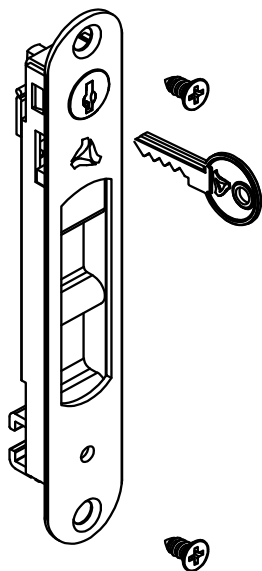

DIMENSÕES:
(escala 1:2)

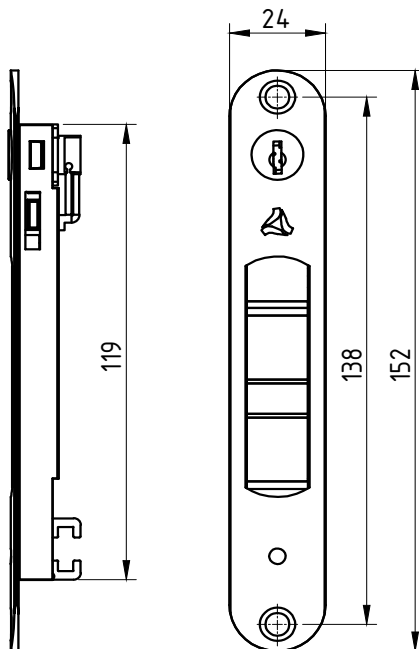

USINAGEM:
(escala 1:2)

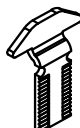
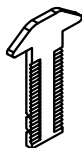
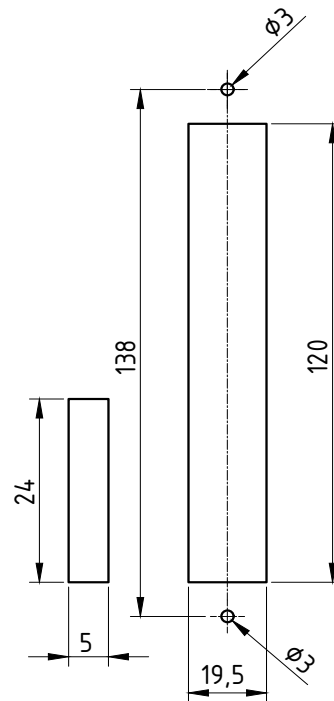

ATENÇÃO:

VERIFICAR QUAL O TIPO DE
TRAVA IDEAL PARA O PROJETO

CÓD: LIN-04 CÓD: LIN-03

CARACTERÍSTICAS:

Componentes:	Matéria-prima:
Estrutura	Alumínio
Lingueta	Aço Inox
Parafusos	Aço Inox
Limitador	Poliamida
Chave	Latão
Cilindro	Zamac

DETALHE DE APLICAÇÃO:
(sem escala)

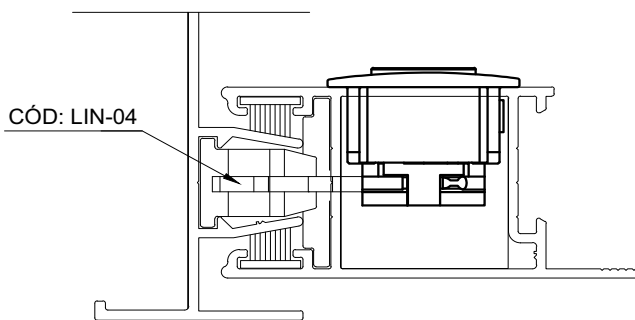

Acabamento Anodizado e Pintado

Preto Fosco Branco

Embalagem

20 Fechos
20 Linguetas
40 Parafusos

CÓDIGO	ACABAMENTO
FEC-202 (Manual)	Preto
FEC-2020 (Manual)	Fosco
FEC-202EB (Manual)	Branco
FEC-203 (Autom.)	Preto
FEC-2030 (Autom.)	Fosco
FEC-203EB (Autom.)	Branco

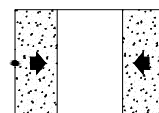

JANELAS
E PORTAS
DE CORRER

Novembro/2015

(escala 1:1)

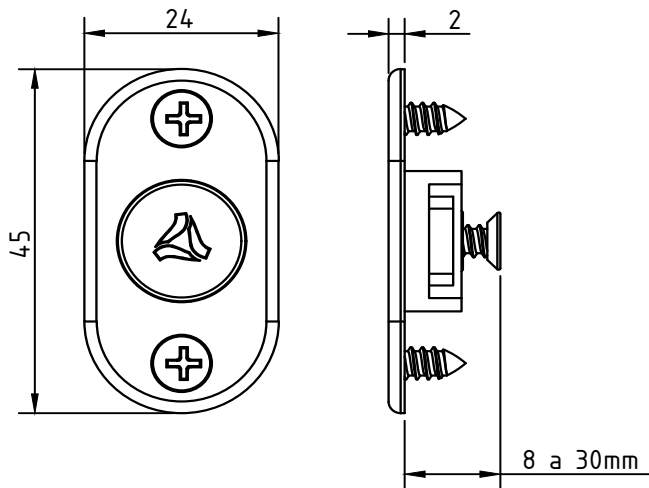

USINAGEM 1:
(escala 1:2)

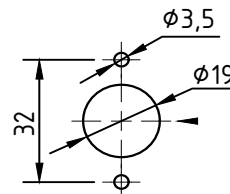

(sem escala)

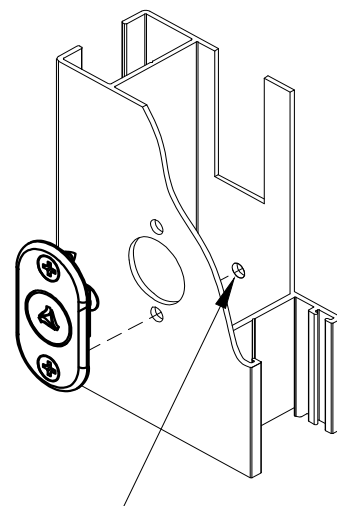

(sem escala)

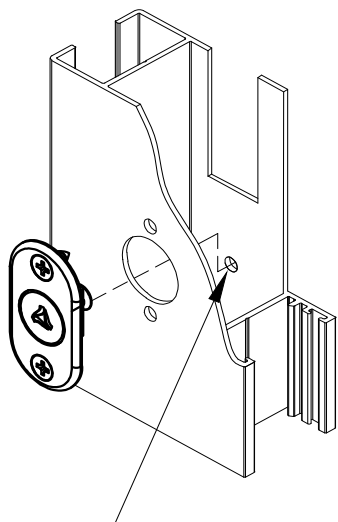

(escala 1:1)

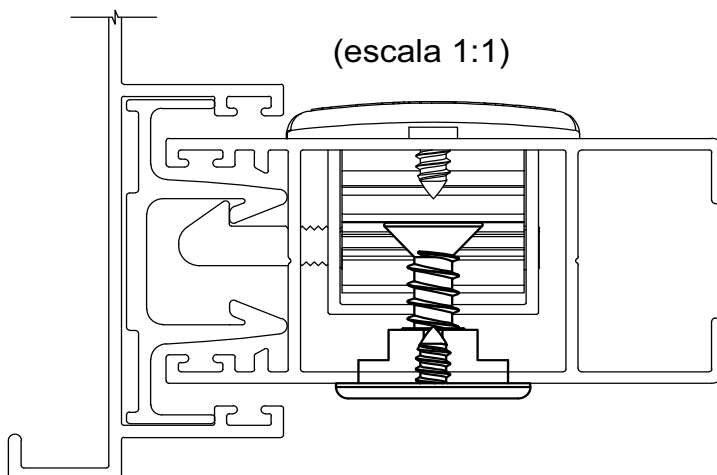

Componentes:	Matéria-prima:
Base	Poliamida
Pino	Poliamida
Parafusos	Aço Inox

Acabamento	
Preto	Branco

Embalagem	01Acionador
	04 Parafusos

CÓDIGO	ACABAMENTO
FEC-0400PT	Preto
FEC-0400BC	Branco

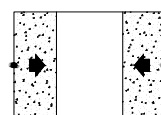

JANELAS
E PORTAS
DE CORRER

PERSPECTIVA:
(sem escala)

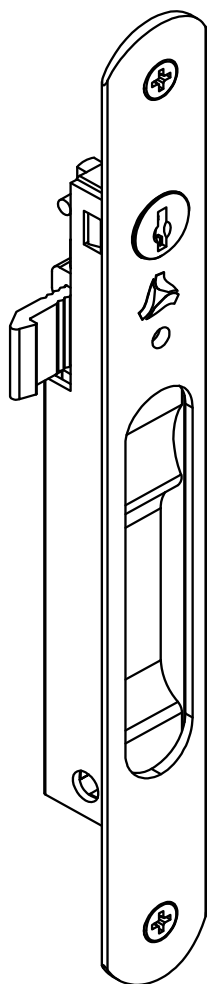

USINAGEM:
(escala 1:2)

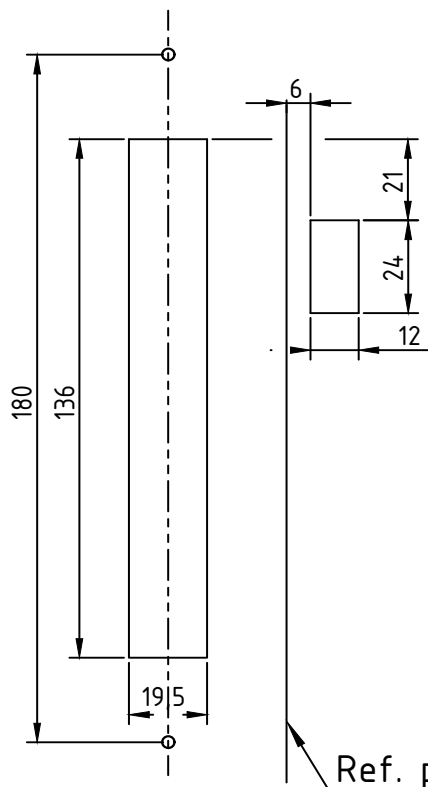

(escala 1:2)

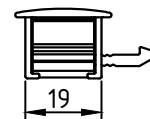
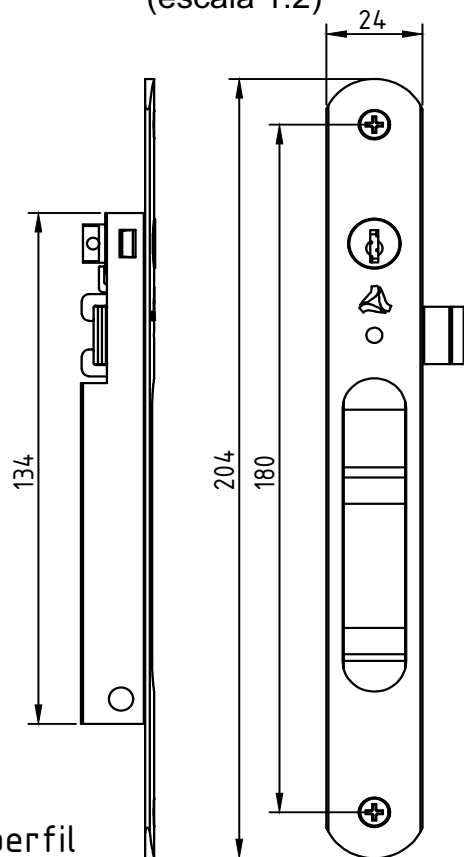

PERFIL- MARCO LATERAL
VENDIDO SEPARADAMENTE
Obs: Verificar a linha indicada para a

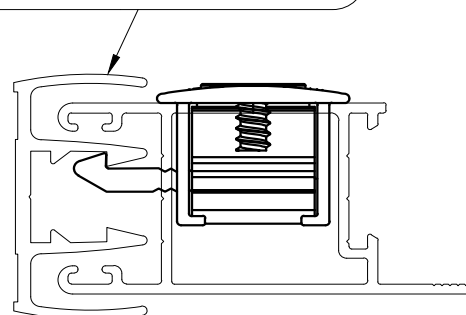

(escala 1:1)

Componentes:

Matéria-prima:

Estrutura

Alumínio

Chave

Aço Niquelado

Lingueta

Alumínio

Parafusos

Aço Inox

Mola

Aço Mola

Eixo de centro

Alumínio

Acabamento Anodizado e Pintado

Preto

Fosco

Branco

Bronze

Embalagem

20 Fechos com chave

20 Linguetas

40 Parafusos

CÓDIGO

ACABAMENTO

FEC-0255PT

Preto

FEC-0255FS

Fosco

FEC-0255BC

Branco

FEC-0255BR

Bronze

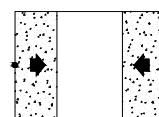

JANELAS
E PORTAS
DE CORRER

PERSPECTIVA:
(sem escala)

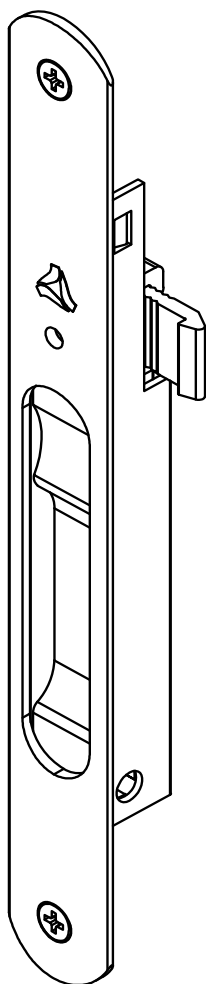

USINAGEM:
(escala 1:2)

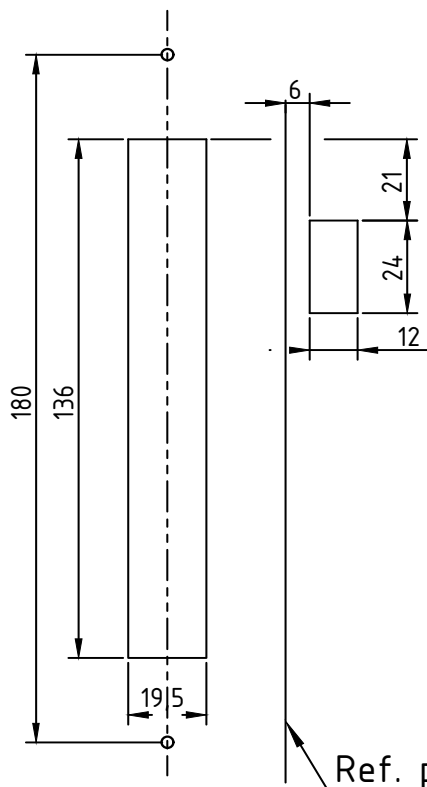

(escala 1:2)

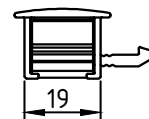
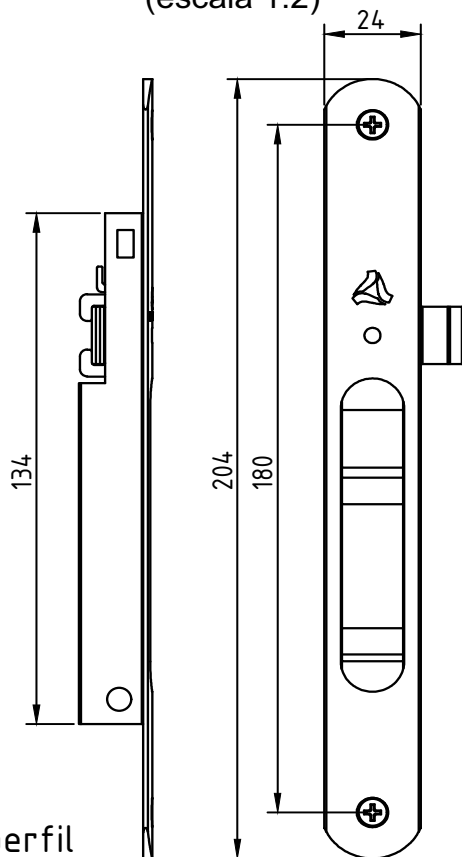

PERFIL- MARCO LATERAL
VENDIDO SEPARADAMENTE
Obs: Verificar a linha indicada para a

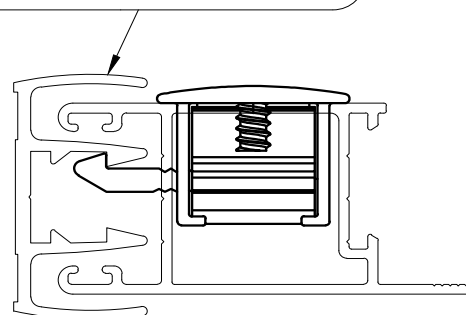

(escala 1:1)

Componentes:

Matéria-prima:

Estrutura

Alumínio

Lingueta

Alumínio

Parafusos

Aço Inox

Mola

Aço Mola

Eixo de centro

Alumínio

Acabamento Anodizado e Pintado

Preto

Fosco

Branco

Bronze

Embalagem

20 Fechos

20 Linguetas

40 Parafusos

CÓDIGO

ACABAMENTO

FEC-0254PT

Preto

FEC-0254FS

Fosco

FEC-0254BC

Branco

FEC-0254BR

Bronze

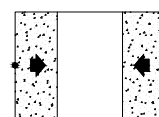

JANELAS
E PORTAS
DE CORRER

PERSPECTIVA:
(sem escala)

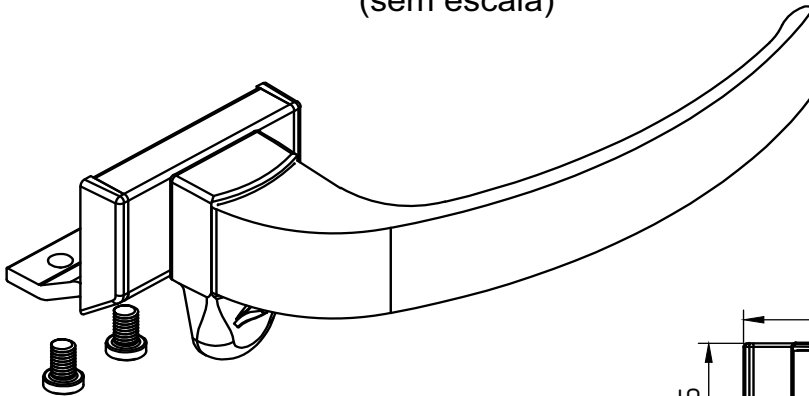

DIMENSÕES:
(escala 1:2)

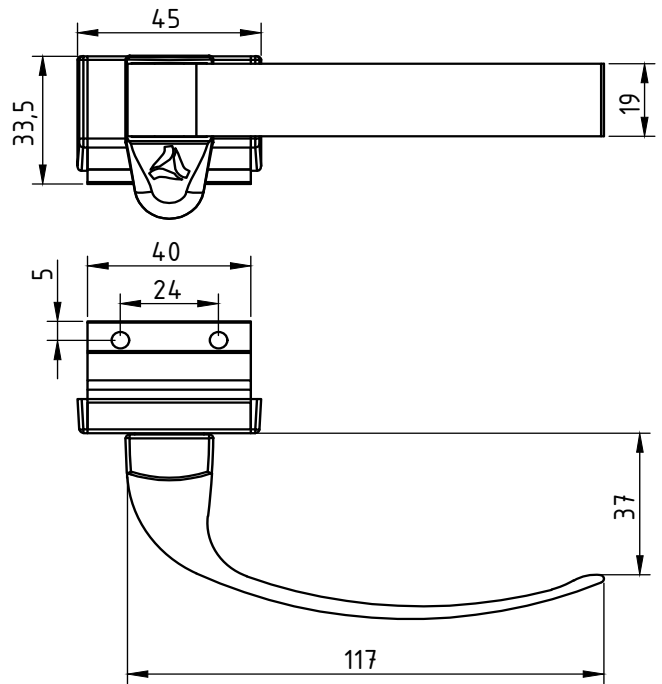

CONTRAFECHO:
(escala 1:2)

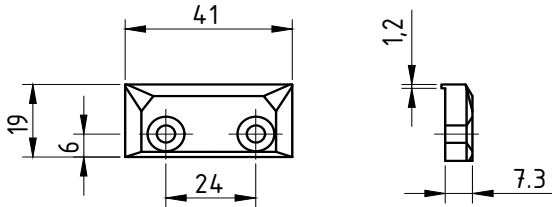

CARACTERÍSTICAS:

Componentes:	Matéria-prima:
Base	Alumínio
Alavanca	Alumínio
Trava	Poliamida
Acabamentos	Poliamida
Arruela	Aço zincado
Parafusos	Aço Inox

Acabamento Anodizado e Pintado

Preto

Branco

Embalagem	10 Fechos
	20 Parafusos
	10 Contrafechos

DETALHE DE APLICAÇÃO:
(escala 1:2)

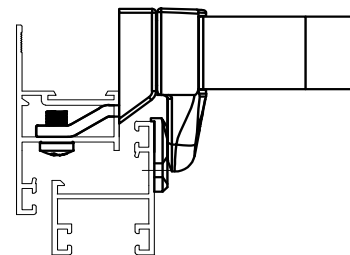

CÓDIGO	ACABAMENTO
FEC-493 (direito)	Preto
FEC-493EB (direito)	Branco
FEC-494 (esq.)	Preto
FEC-494EB (esq.)	Branco

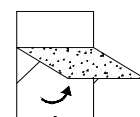

JANELAS
MAXIM-AR

PERSPECTIVA:
(escala 1:1)

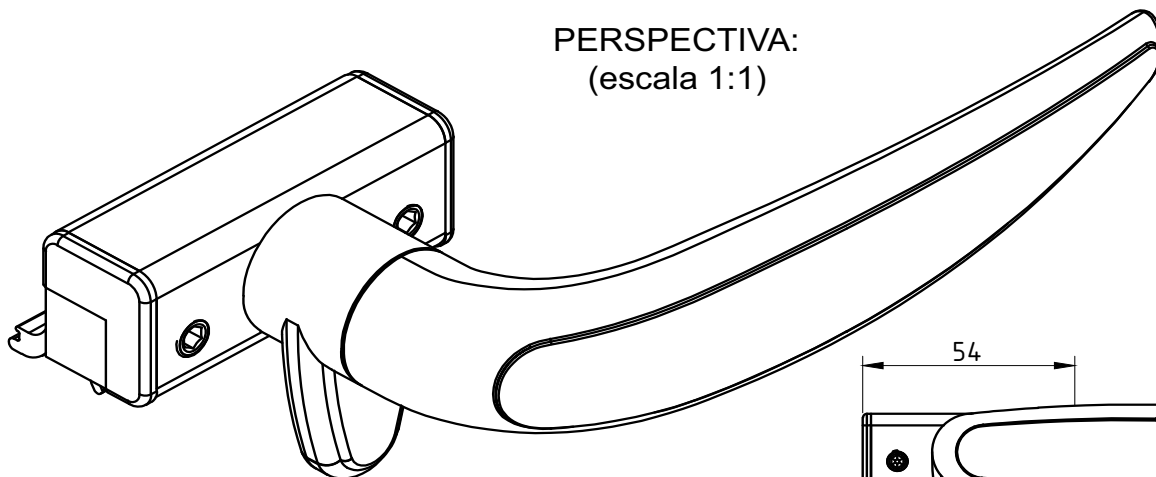

DIMENSÕES:
(escala 1:2)

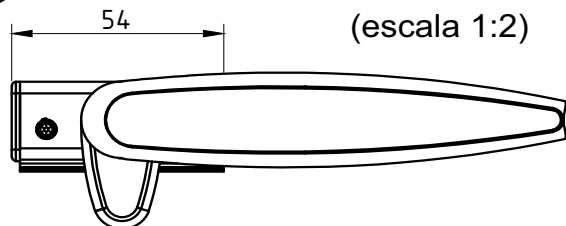

CONTRAFECHO:
(escala 1:2)

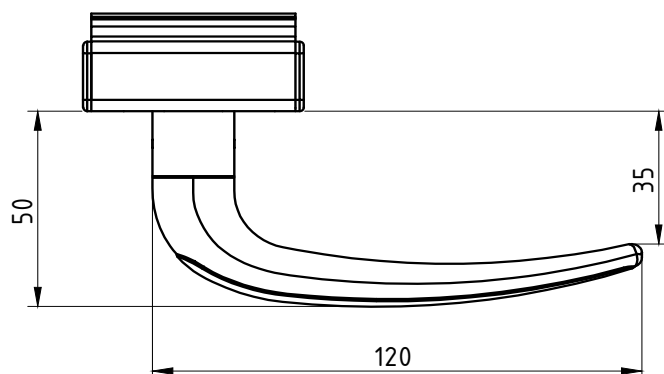
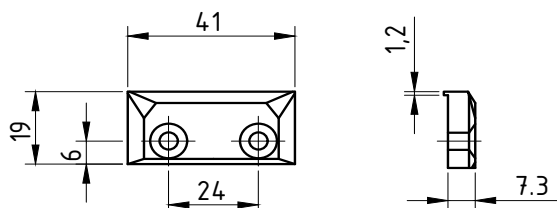

DETALHE DE APLICAÇÃO:
(escala 1:2)

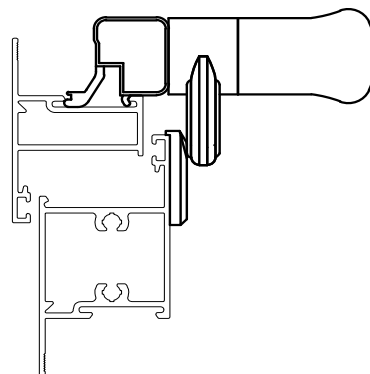

CARACTERÍSTICAS:

Componentes:	Matéria-prima:
Base	Alumínio
Alavanca	Zamac
Tampas	Poliamida
Trava	Zamac
Arruela	Aço inox
Parafusos	Aço Inox

Acabamento Pintado

Preto

Branco

Embalagem

10 Fechos
20 Tampas
20 Parafusos

CÓDIGO	ACABAMENTO
FEC-604D/P	Preto
FEC-604D/EB	Branco
FEC-604E/P	Preto
FEC-604E/EB	Branco

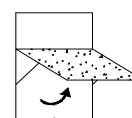

JANELAS
MAXIM-AR

Fevereiro/2008

PERSPECTIVA (SEM ESCALA)

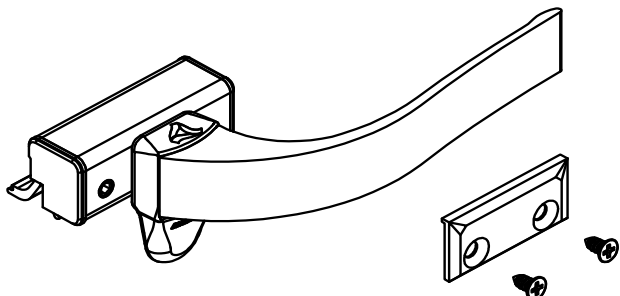

INSTALAÇÃO DO FECHO

1) Encaixe o fecho no perfil da folha conforme figura.

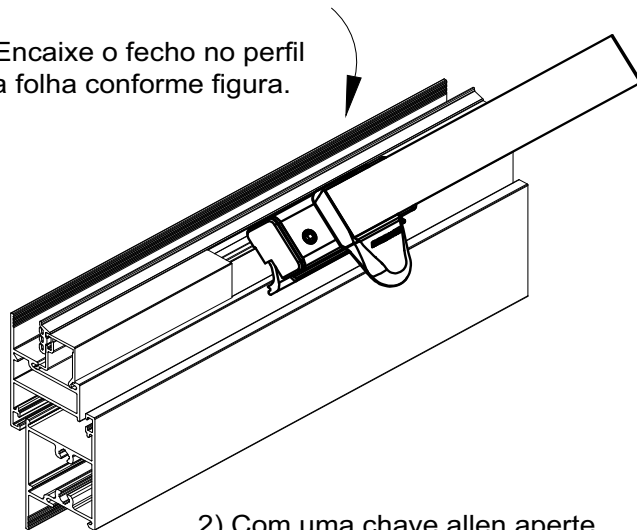

2) Com uma chave allen aperte o parafuso da base para travamento.

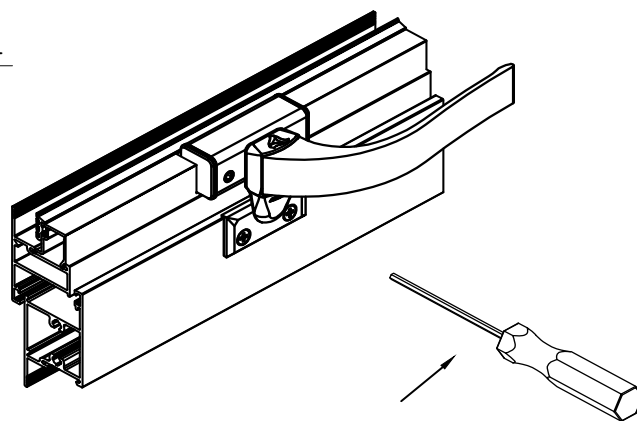

Chave Allen
(Não Fornecido)

DIMENSÕES (ESCALA 1:3)

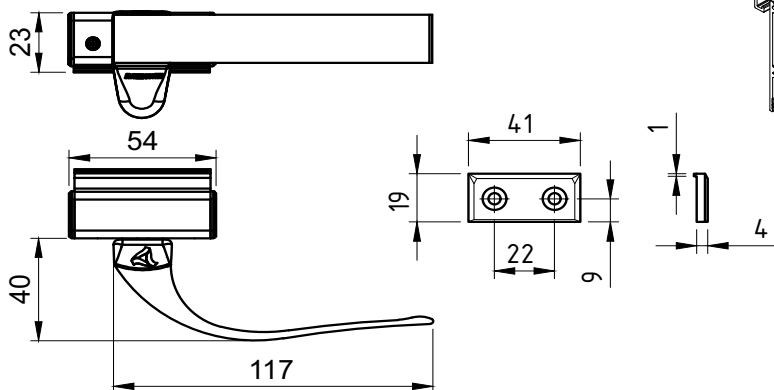

USINAGEM (ESCALA 1:2)

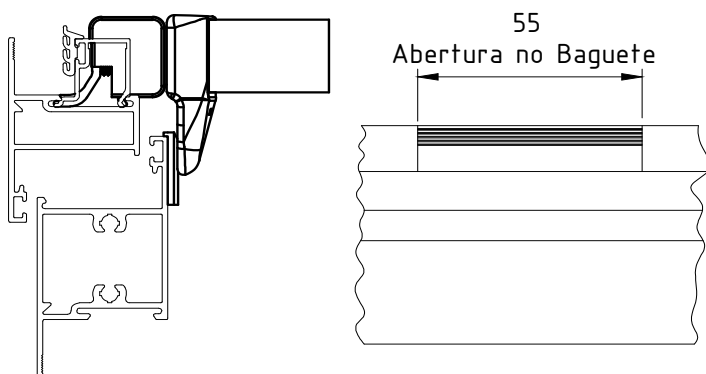

INSTALAÇÃO DO CONTRAFECHO

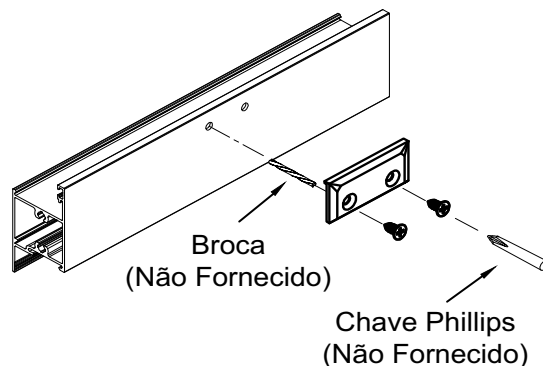

Broca
(Não Fornecido)

Chave Phillips
(Não Fornecido)

CARACTERÍSTICAS:

Componentes:	Matéria-prima:
Alavanca - Base	Alumínio
Trava - Tampas	Poliamida
Contrafecho	Poliamida
Arruela	Aço Zincado
Parafusos	Aço Inox

Acabamento Anodizado e Pintado		
Preto	Fosco	Branco

Embalagem	25 Conjuntos
-----------	--------------

DIREITO	ESQUERDO	ACABAMENTO
FEC-0026FS	FEC-0027FS	Fosco
FEC-0026PT	FEC-0027PT	Preto
FEC-0026BC	FEC-0027BC	Branco
FEC-0026BZ	FEC-0027BZ	Bronze

JANELAS MAXIM-AR

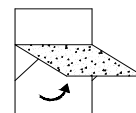

PERSPECTIVA
ESCALA 1:2

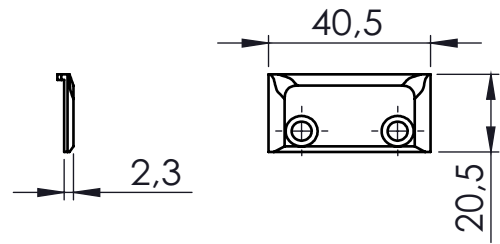
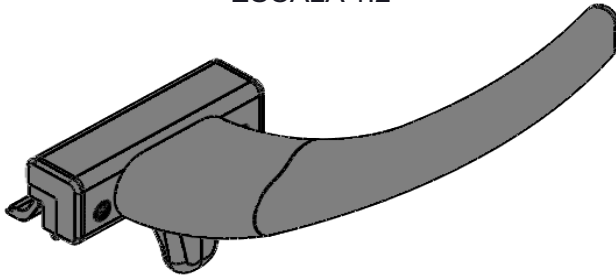

DIMENSÕES
ESCALA 1:2

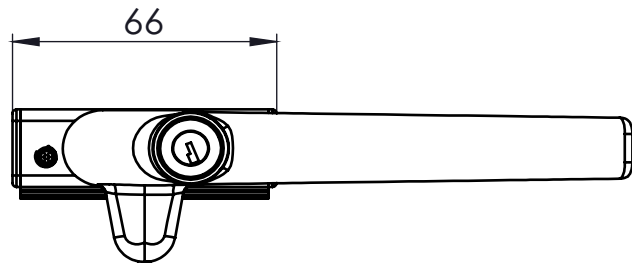
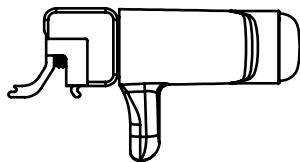
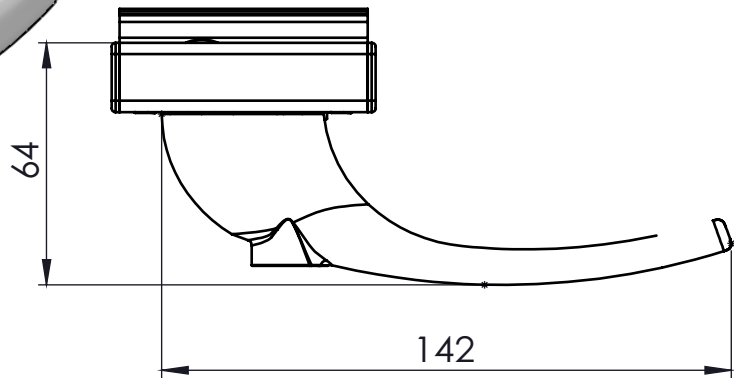
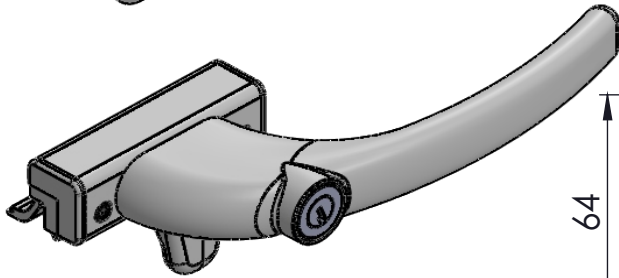

APLICAÇÃO
ESCALA 1:2

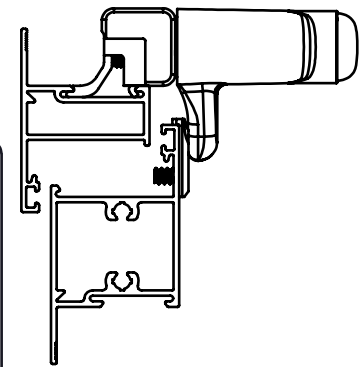

CARACTERÍSTICAS:

Componentes:	Matéria-prima:
Base	Alumínio
Alavanca	Alumínio
Tampas	Poliamida
Trava	Alumínio
Arruela	Poliamida
Parafusos	Aço Inox

Acabamento Pintado	
Branco	Preto

Embalagem	10 Fechos
	10 tampas/contrafechos
	40 Parafusos

CÓDIGO	DESCRIÇÃO
FEC4004BC	Branco s/chave direito
FEC4004PT	Preto s/chave direito
FEC4005BC	Branco s/chave esquerdo
FEC4005PT	Preto s/chave esquerdo
FEC4006BC	Branco c/chave direito
FEC4006PT	Preto c/chave direito
FEC4007BC	Branco c/chave esquerdo
FEC4007PT	Preto c/chave esquerdo



JANELAS
MAXIM-AR

Novembro/2008

CÓDIGO	DESCRIÇÃO
GUI - 01	Guia da Cinta em poliamida preto
GUI - 01EB	Guia da Cinta em poliamida branco

Usinagem
(S/ Escala)

Dimensões
(Escala 1:1,5)

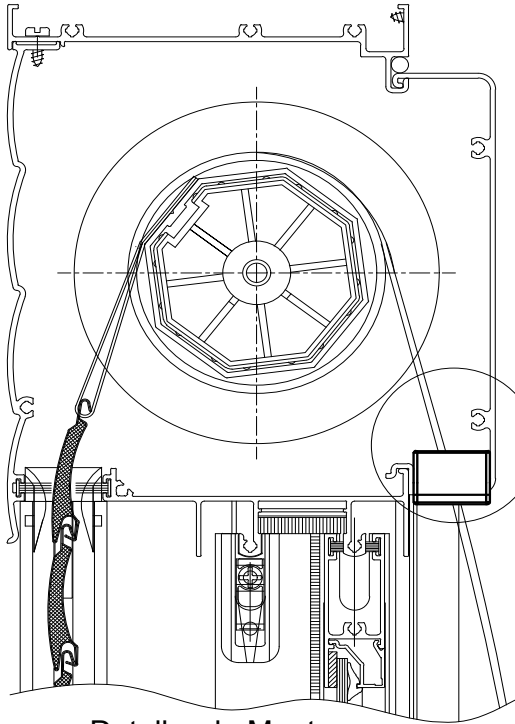

Detalhe de Montagem
(S/ Escala)

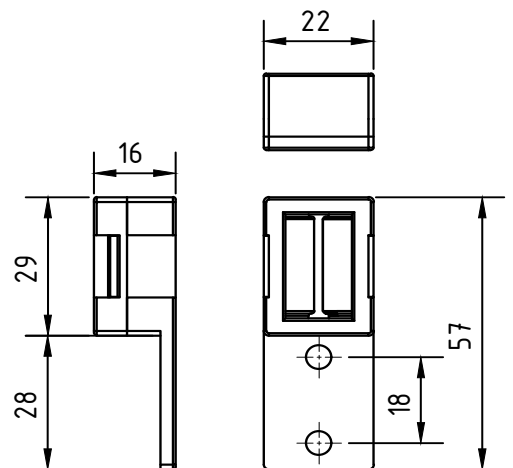
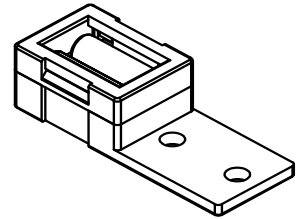
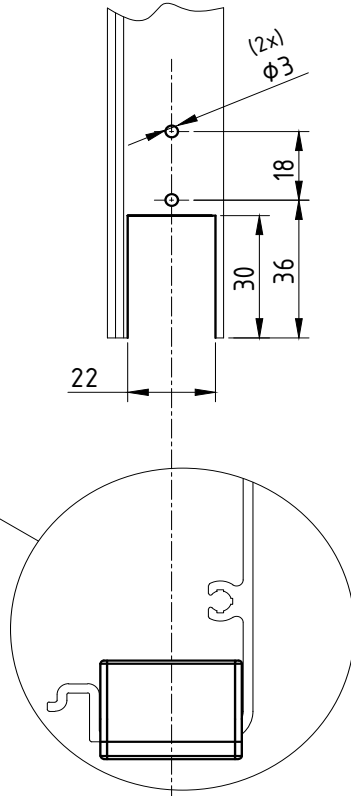

CÓDIGO	DESCRIÇÃO
GUI - 02	Guia da Cinta em poliamida preto
GUI - 02EB	Guia da Cinta em poliamida branco

Detalhe de Montagem
(S/ Escala)

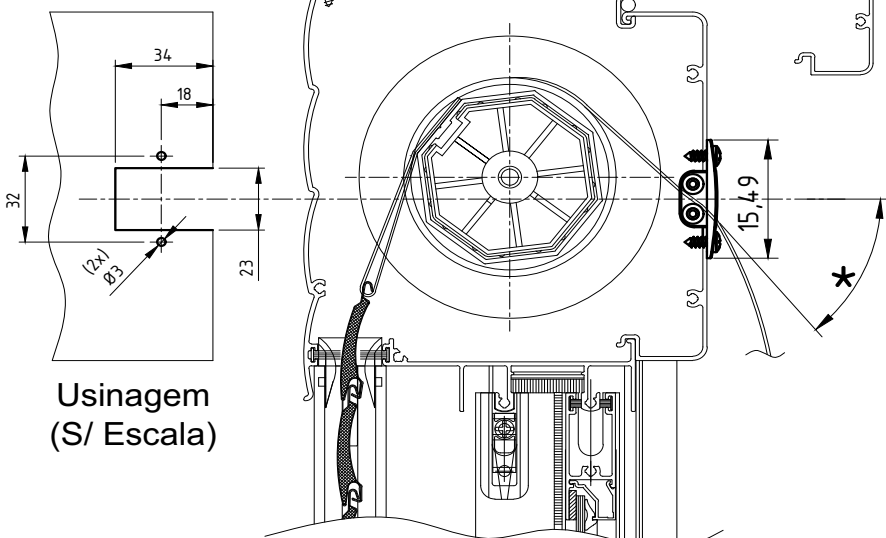

Usinagem
(S/ Escala)

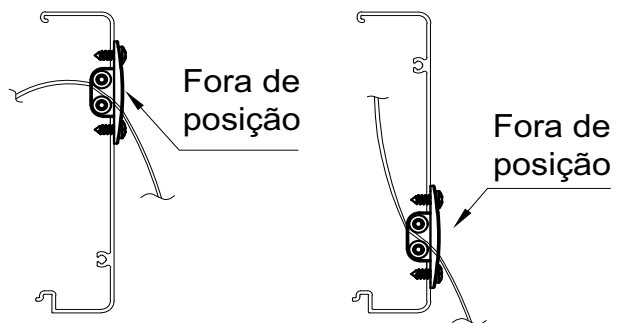

Dimensões
(Escala 1:2)

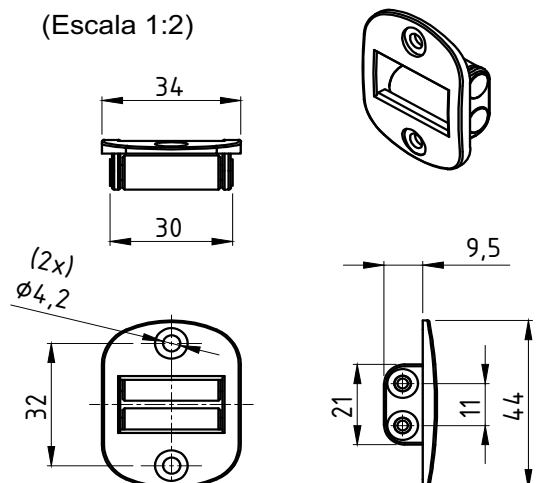

* OBS: ACONSELHAMOS MANTER UM ÂNGULO DE FIXAÇÃO CONFORME DETALHADO PARA NÃO PROVOCAR ESFORÇO EXCESSIVO NA GUIA DA CINTA.

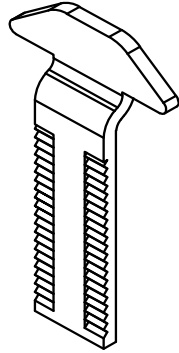

LIN-06

TORTA

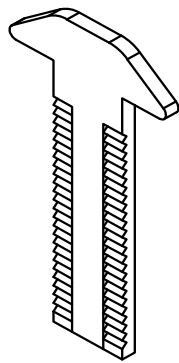
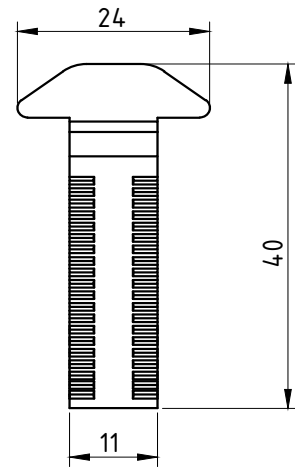

LIN-04

RETA

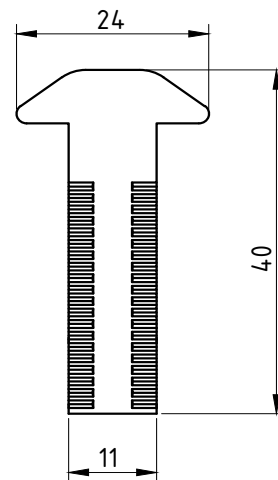

Embalagem

20 Linguetas

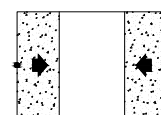

JANELAS
E PORTAS
DE CORRER

DIMENSÕES:
(sem escala)

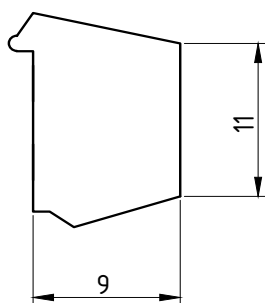
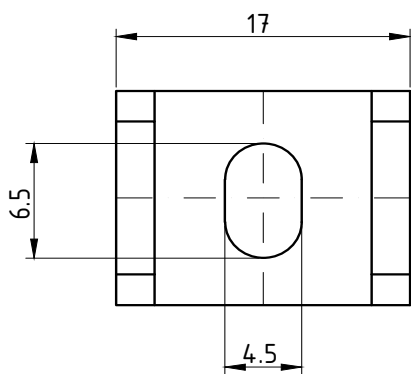

PERSPECTIVA:
(escala 1:1)

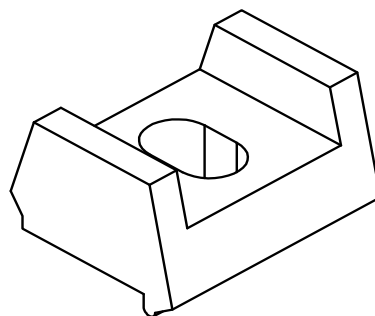

DETALHE DE APLICAÇÃO:
(sem escala)

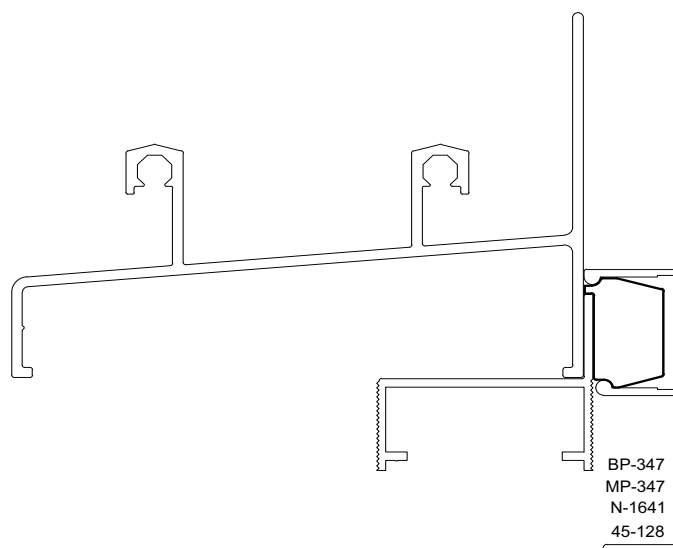

CARACTERÍSTICAS:

Componentes:

Matéria-prima:

Estrutura

Poliamida

Acabamento

Preto

Embalagem

200 Peças

CÓDIGO	ACABAMENTO
NYL- 190	Preto

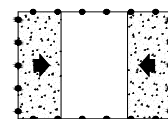

DIVERSAS

DIMENSÕES:
(escala 1:1)

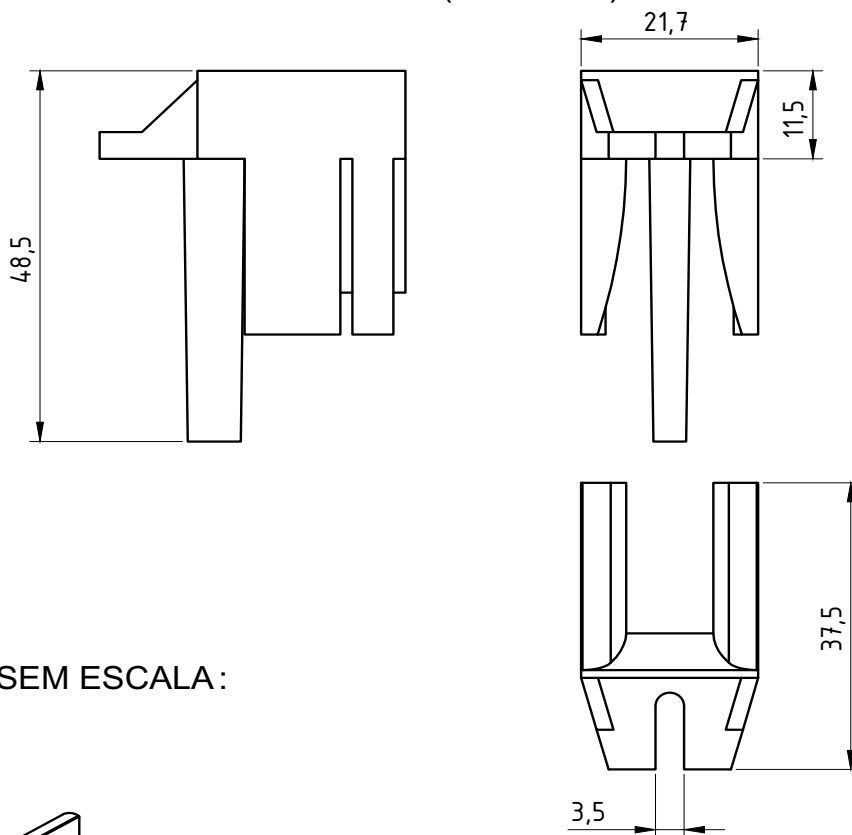

PERSPECTIVA SEM ESCALA:

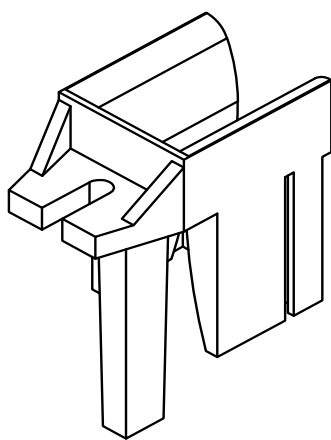

DETALHE DE APLICAÇÃO:
(sem escala)

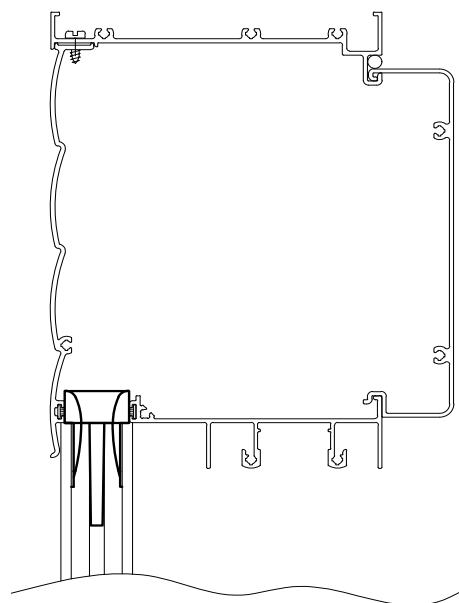

CARACTERÍSTICAS:

Componentes:	Matéria-prima:
Estrutura	Poliamida
Parafuso	Aço Inox

Acabamento	Preto
-------------------	--------------

Embalagem	25 Peças
	25 Parafusos

CÓDIGO	ACABAMENTO
NYL-370	Preto

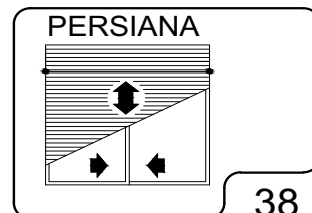

DIMENSÕES:
(escala 1:1)

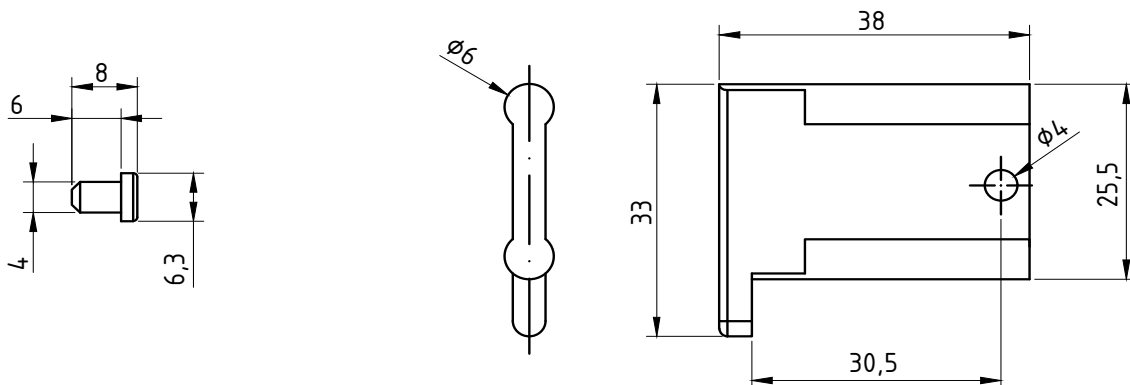

PERSPECTIVA SEM ESCALA:

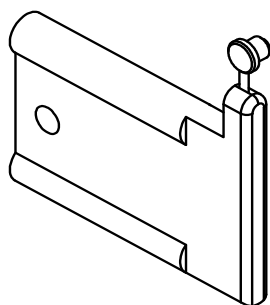

DETALHE DE APLICAÇÃO:
(sem escala)

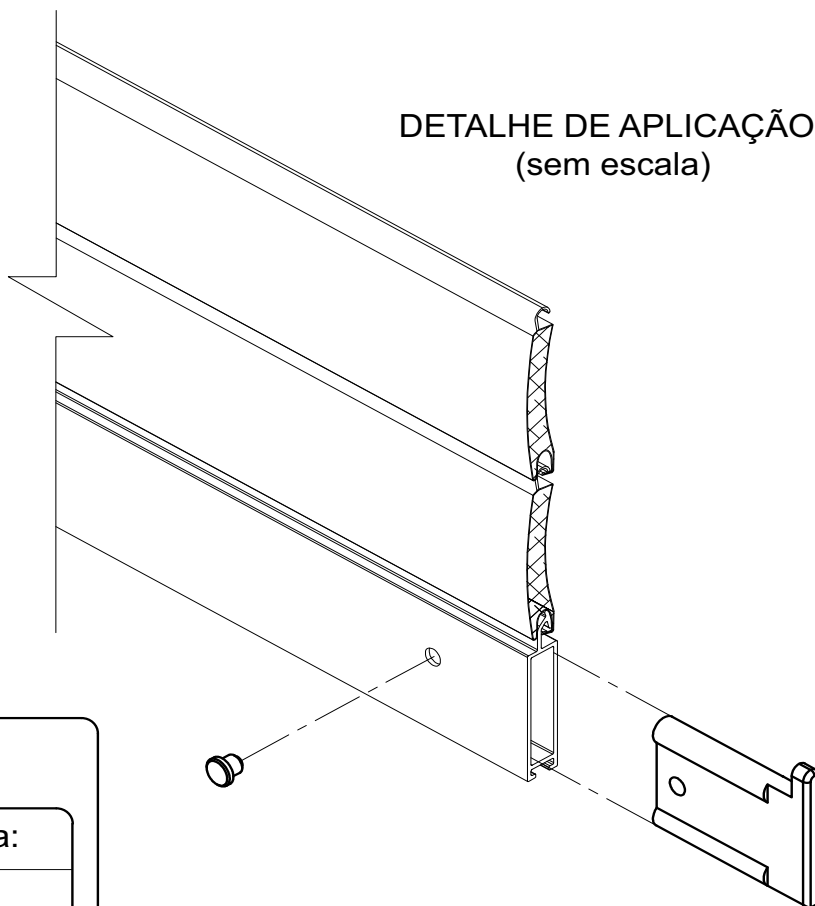

CARACTERÍSTICAS:

Componentes:	Matéria-prima:
Estrutura	Poliamida
Pino	Poliamida

Acabamento	Preto
------------	-------

Embalagem	25 Peças
-----------	----------

CÓDIGO	ACABAMENTO
NYL-369	Preto

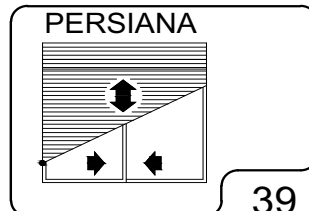

DIMENSÕES:
(escala 1:2)

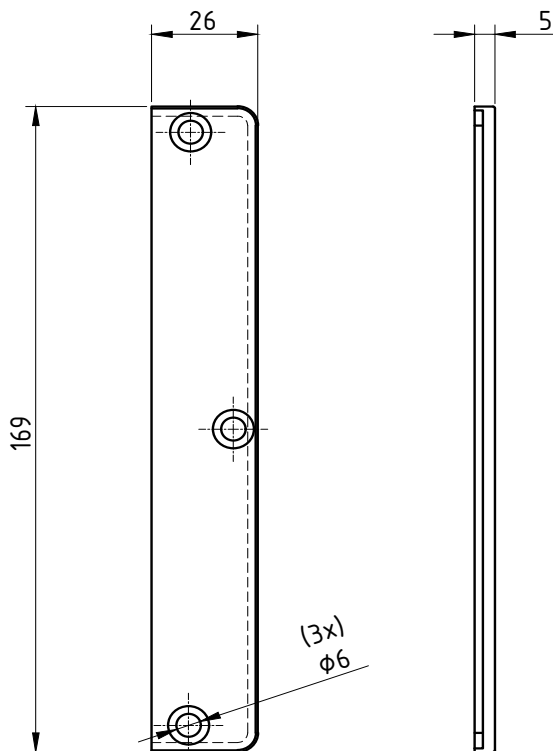

PERSPECTIVA:
(escala 1:2)

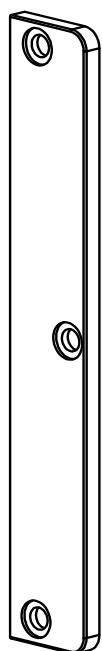

DETALHE DE APLICAÇÃO:
(sem escala)

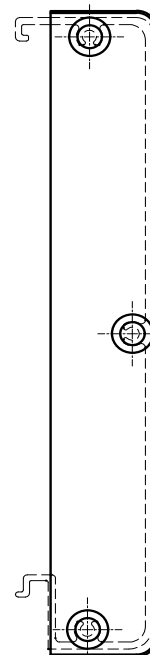

CARACTERÍSTICAS:

Componentes:	Matéria-prima:
Estrutura	Poliamida
Parafusos	Aço Inox

Acabamentos	
Preto	Branco

Embalagem	20 Peças
	60 Parafusos

CÓDIGO	ACABAMENTO
NYL- 382	Preto
NYL- 382NB	Branco

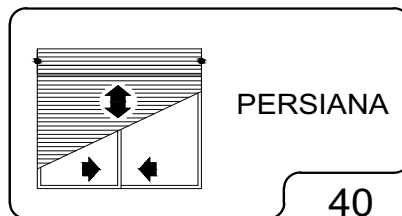

DIMENSÕES:
(escala 1:2)

PERSPECTIVA:
(escala 1:2)

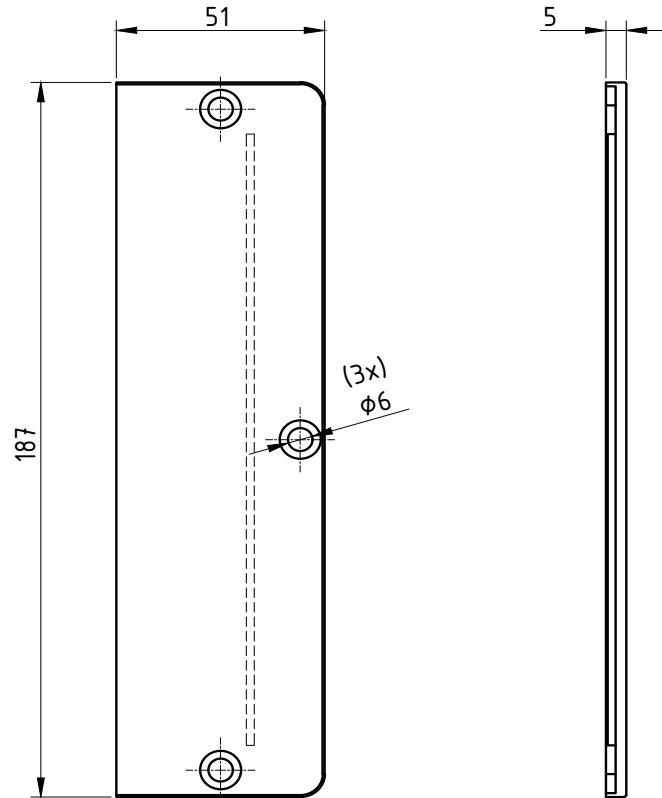
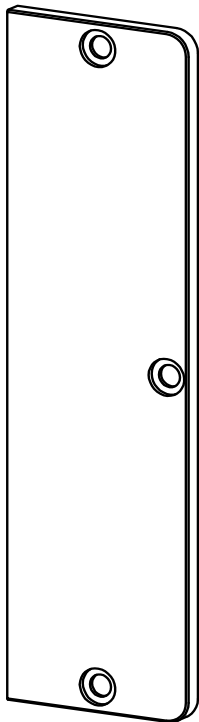

DETALHE DE APLICAÇÃO:
(sem escala)

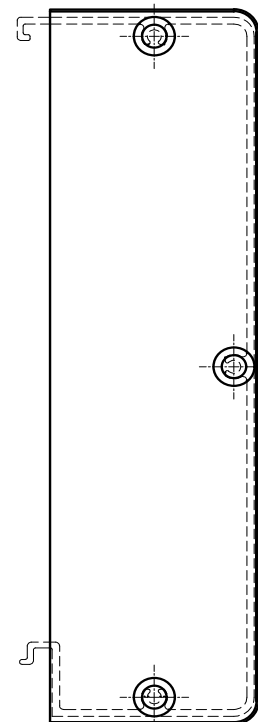

CARACTERÍSTICAS:

Componentes:	Matéria-prima:
Estrutura	Poliamida
Parafusos	Aço Inox

Acabamentos	
Preto	Branco

Embalagem	20 Peças
	60 Parafusos

CÓDIGO	ACABAMENTO
NYL- 383	Preto
NYL- 383NB	Branco

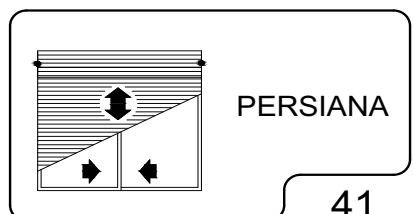

PERSIANA

DIMENSÕES:
(escala 1:1)

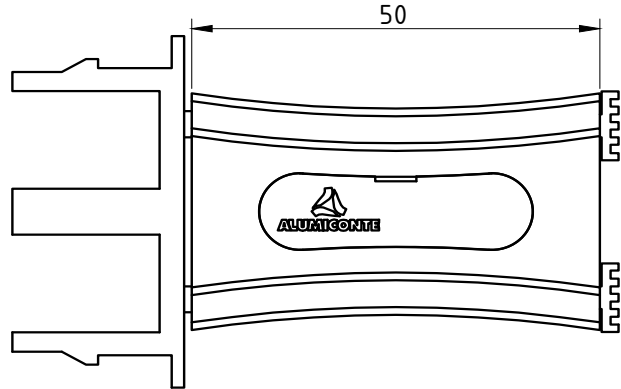
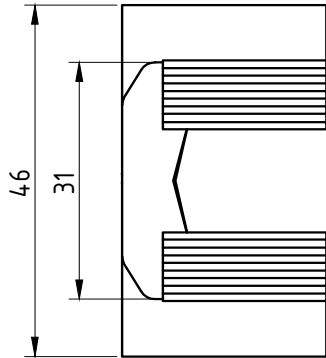

PERSPECTIVA:
(Sem escala)

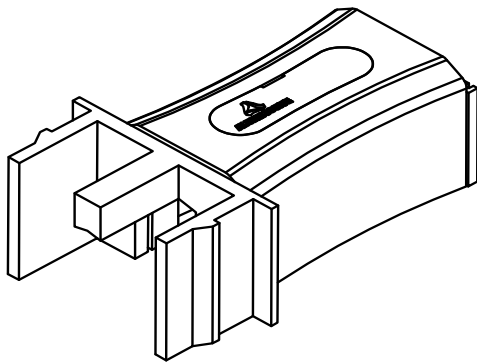

DETALHE DE APLICAÇÃO:
(sem escala)

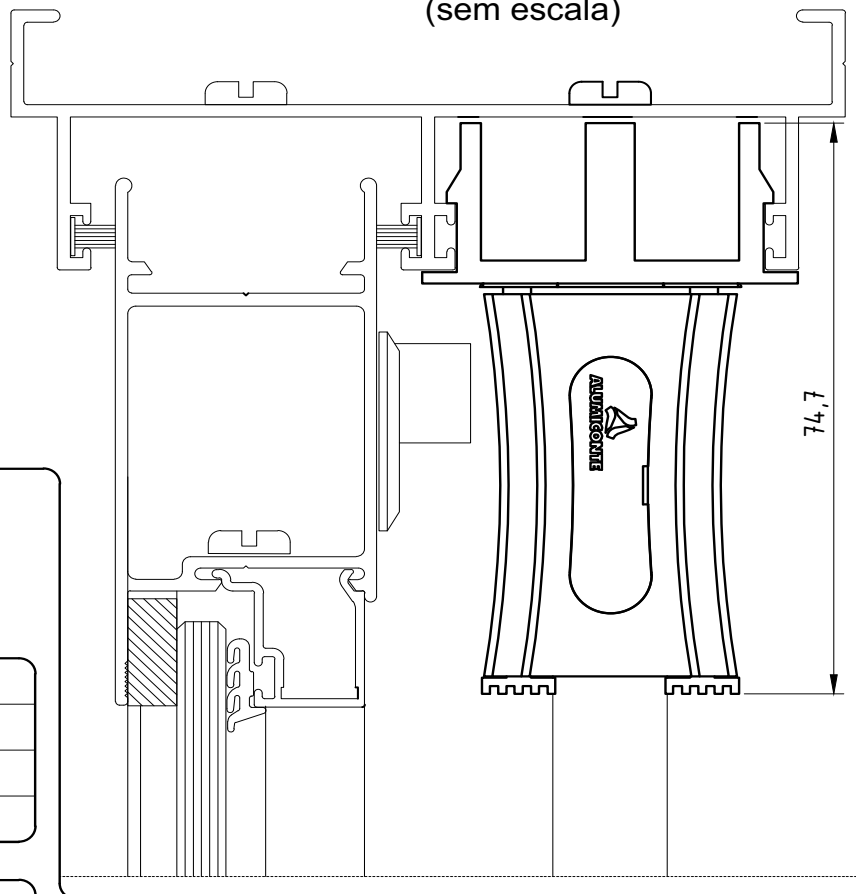

CARACTERÍSTICAS:

Componentes:	Matéria-prima:
Estrutura	Poliamida
Guarnição	EPDM
Parafuso	Aço Inox

Acabamentos	
Preto	Branco

Embalagem	20 peças
-----------	----------

CÓDIGO	ACABAMENTO
NYL- 347	Preto
NYL- 347NB	Branco

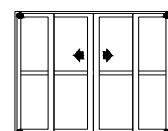

JANELAS
E PORTAS
DE CORRER

DIMENSÕES:
(escala 1:1)

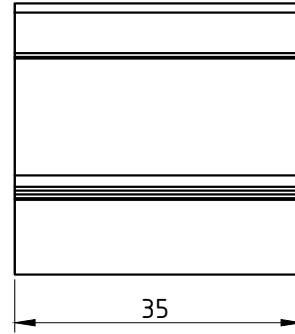
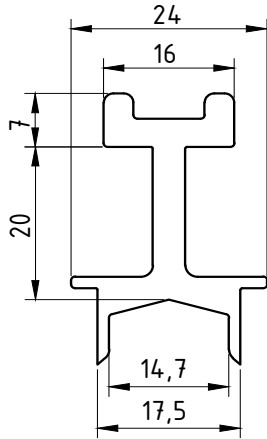

PERSPECTIVA SEM ESCALA:

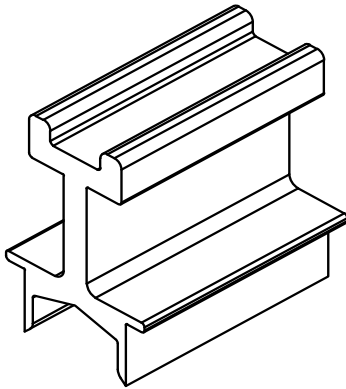

DETALHE DE APLICAÇÃO:
(sem escala)

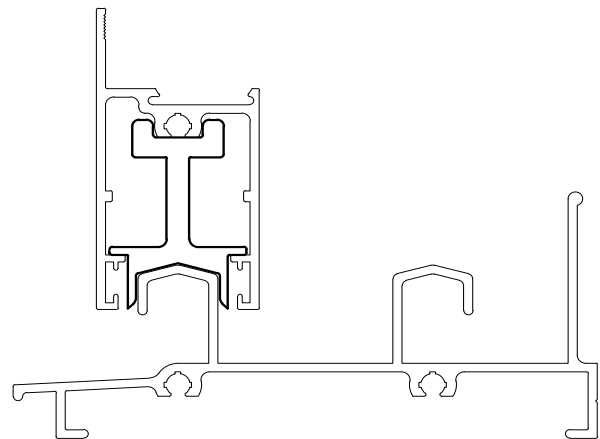

CARACTERÍSTICAS:

Componentes:	Matéria-prima:
--------------	----------------

Estrutura	Poliamida
-----------	-----------

Acabamento	Preto
------------	-------

Embalagem	10 Peças
-----------	----------

CÓDIGO	ACABAMENTO
--------	------------

NYL-394	Preto
---------	-------

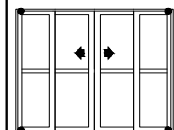

JANELAS
E PORTAS
DE CORRER

DIMENSÕES:
(escala 1:1)

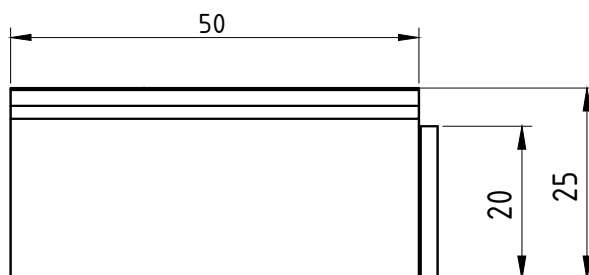

PERSPECTIVA:
(escala 1:1)

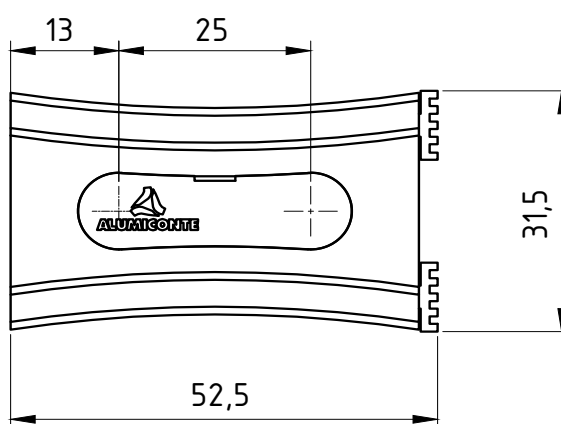
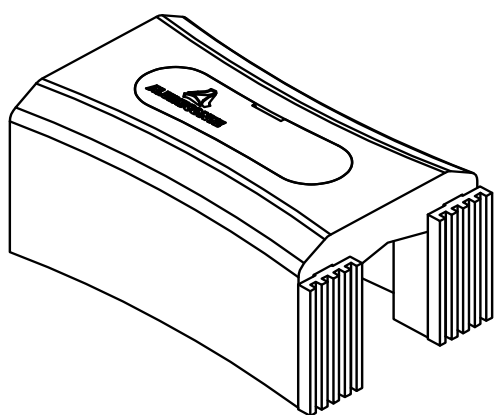

DETALHE DE APLICAÇÃO:
(sem escala)

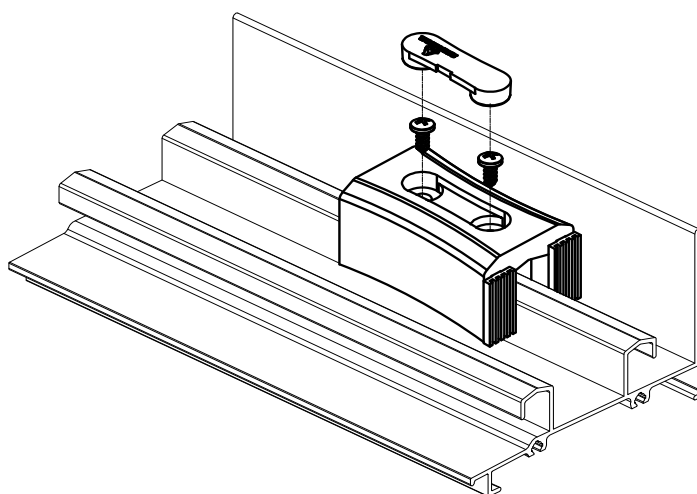

CARACTERÍSTICAS:

Componentes:	Matéria-prima:
Estrutura	Poliamida
Guarnição	EPDM
Parafuso	Aço Inox

Acabamentos

Preto

Branco

Embalagem

20 peças

CÓDIGO	ACABAMENTO
NYL- 398	Preto
NYL- 398NB	Branco

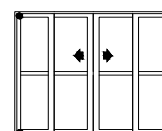

JANELAS
E PORTAS
DE CORRER

DIMENSÕES:
(escala 1:1)

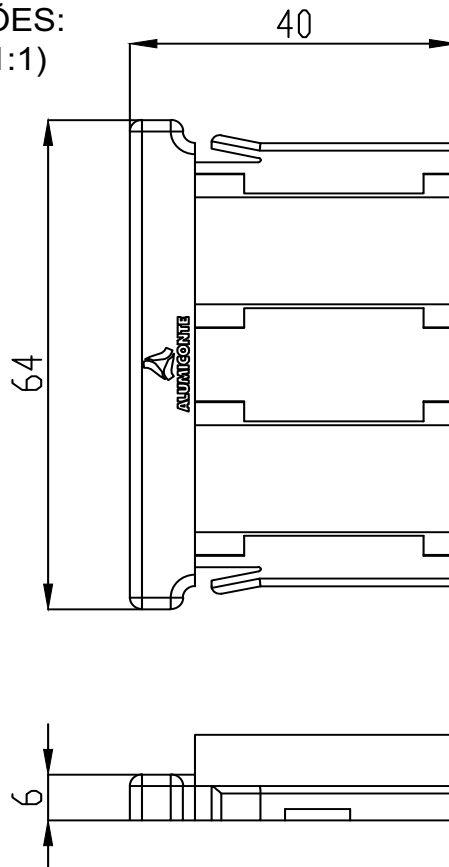

PERSPECTIVA:
(Sem escala)

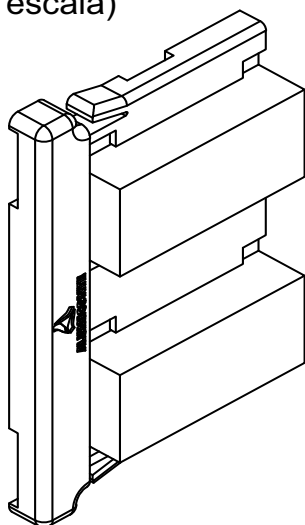

DETALHES DE APLICAÇÃO:
(sem escala)

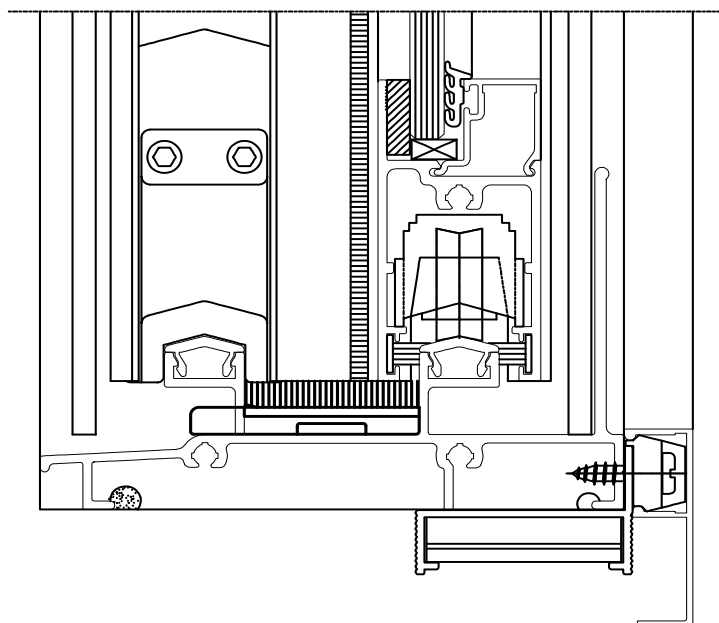

CARACTERÍSTICAS:

Componentes:	Matéria-prima:
Estrutura	Poliamida
Fita Vedadora	Polipropileno

Acabamento	Branco
------------	--------

Embalagem	100 Peças
-----------	-----------

CÓDIGO	ACABAMENTO
NYL-395	Preto
NYL-395NB	Branco

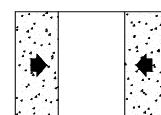

JANELAS E
PORTAS
DE CORRER

Agosto/2010

DIMENSÕES:
(escala 1:1)

PERSPECTIVA:
(escala 1:1)

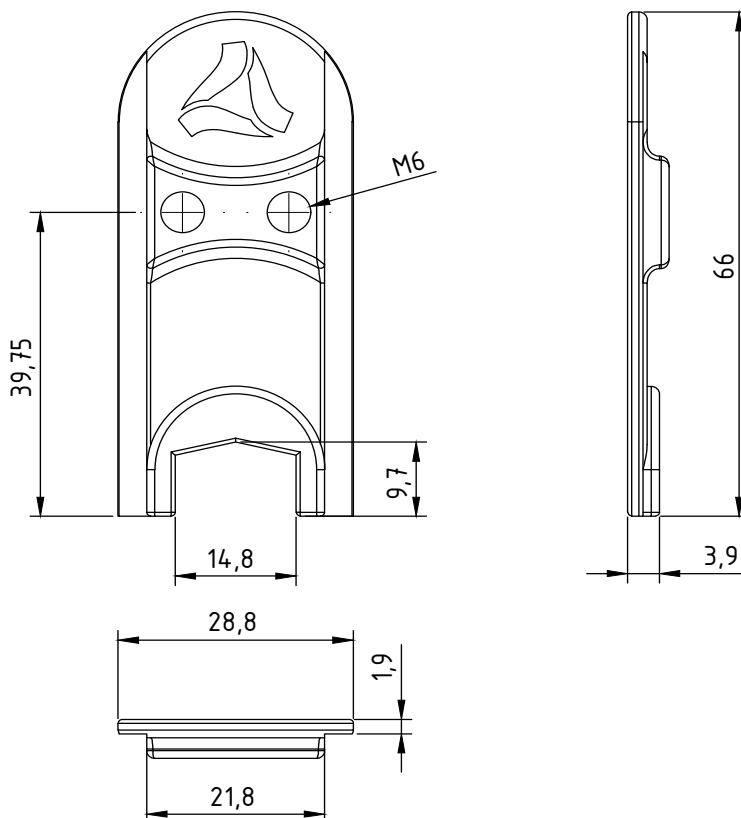
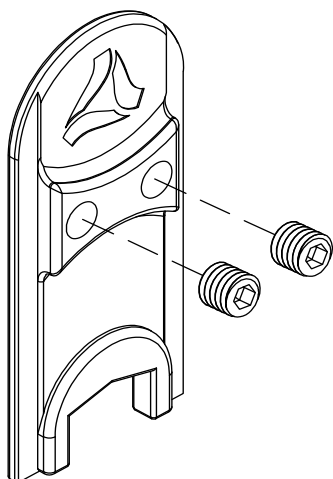

DETALHE DE APLICAÇÃO:
(sem escala)

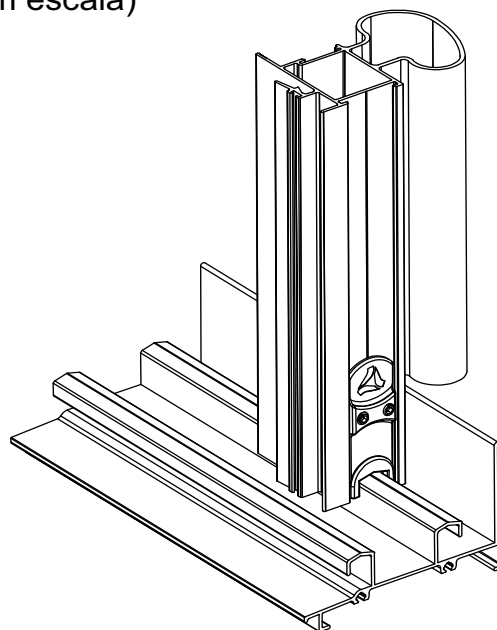

CARACTERÍSTICAS:

Componentes:	Matéria-prima:
Estrutura	Poliamida
Parafusos	Aço Inox

Acabamentos	
Preto	Branco

Embalagem	100 Guias
-----------	-----------

CÓDIGO	ACABAMENTO
NYL-396	Preto
NYL-396NB	Branco

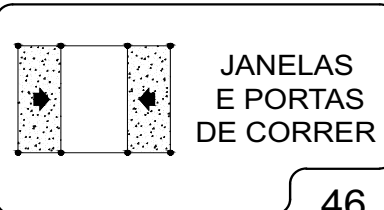

DIMENSÕES:
(escala 1:1)

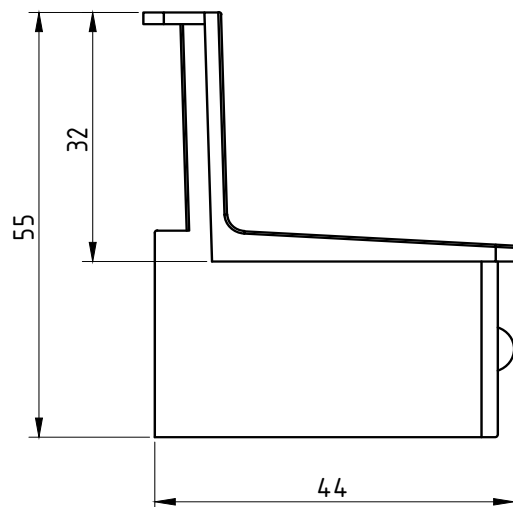
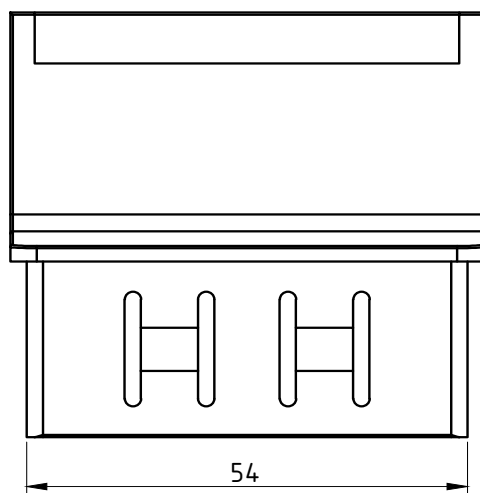

PERSPECTIVA SEM ESCALA:

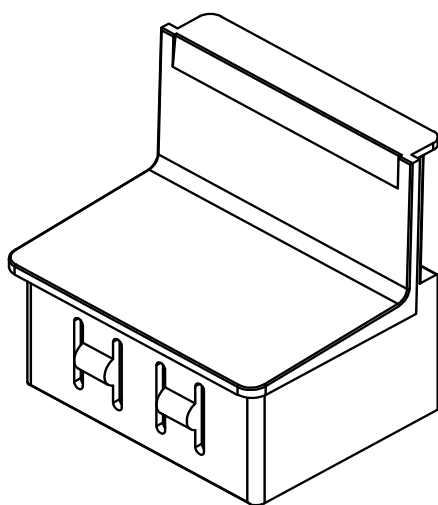

DETALHE DE APLICAÇÃO:
(sem escala)

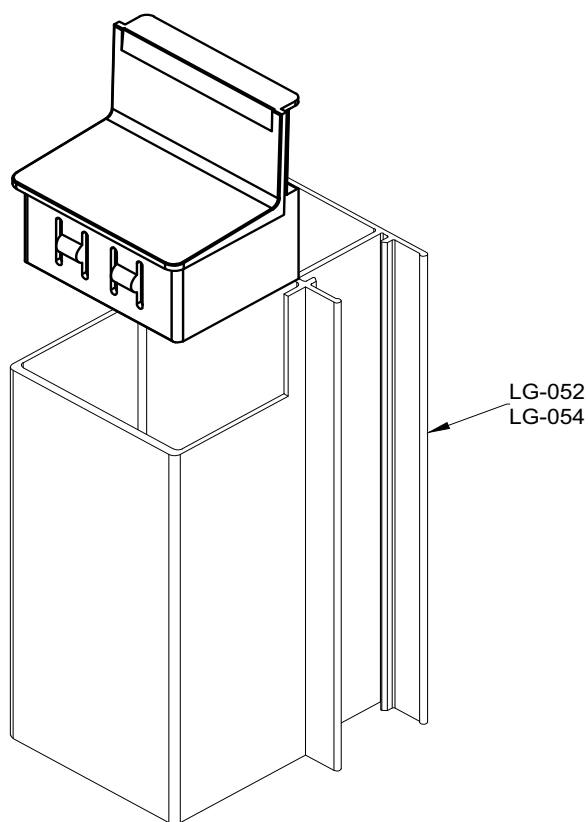

CARACTERÍSTICAS:

Componentes:	Matéria-prima:
Estrutura	Poliamida

Acabamento	Preto	Branco
------------	-------	--------

Embalagem	20 Peças
-----------	----------

CÓDIGO	ACABAMENTO
NYL-399	Preto
NYL-399NB	Branco



DIMENSÕES:
(escala 1:1)

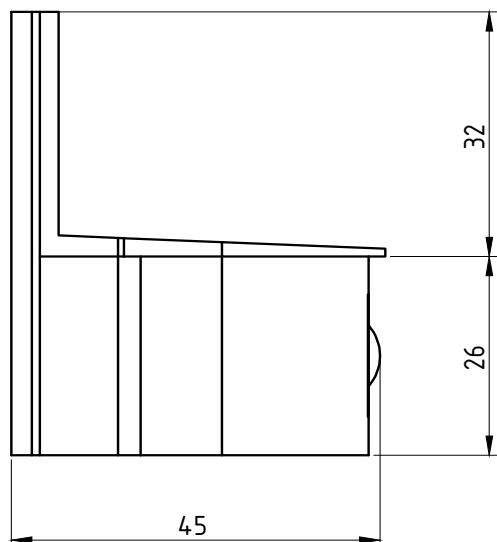

PERSPECTIVA:
(Sem Escala)

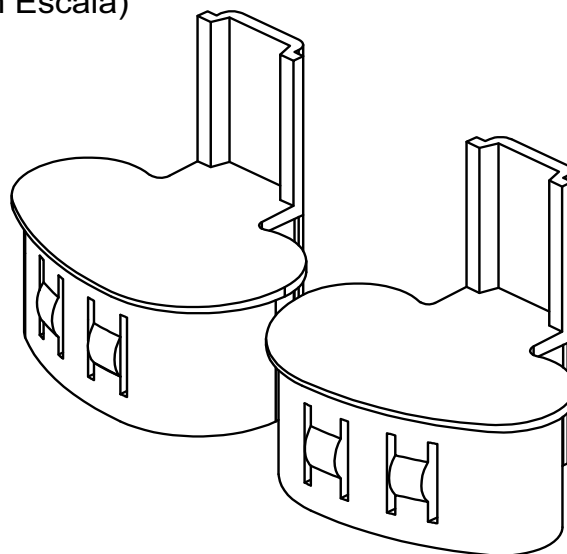

DETALHE DE APLICAÇÃO:
(sem escala)

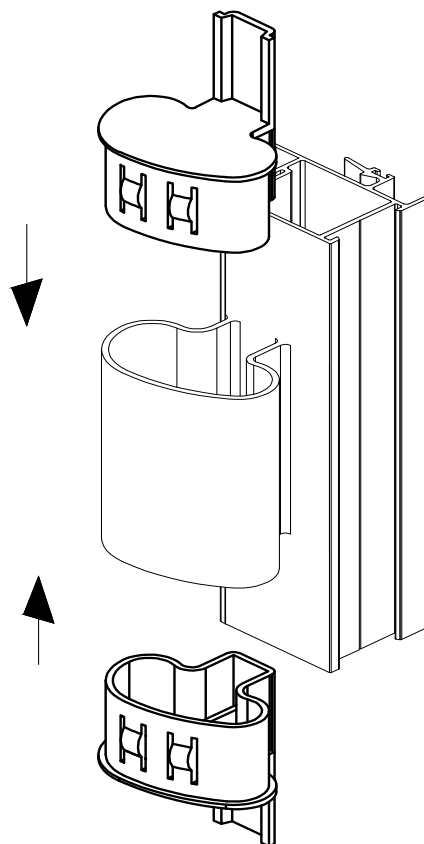
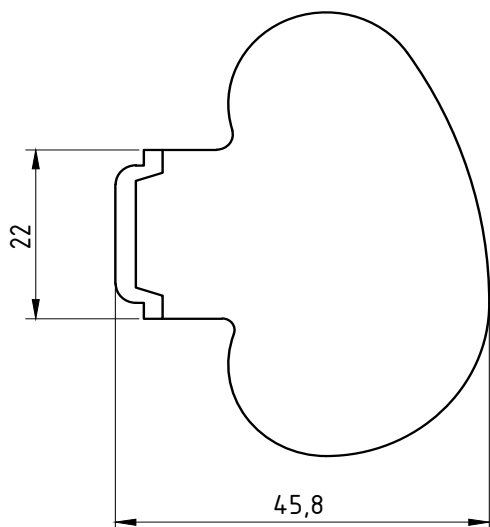

CARACTERÍSTICAS:

Componentes:	Matéria-prima:
Estrutura	Poliamida

Acabamentos

Preto	Branco
-------	--------

Embalagem	10 Pares
-----------	----------

CÓDIGO	ACABAMENTO
NYL- 400	Preto
NYL- 400NB	Branco

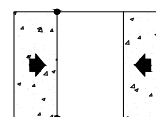

JANELAS
E PORTAS
DE CORRER

DIMENSÕES:
(escala 2:1)

PERSPECTIVA:
(sem escala)

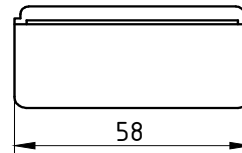
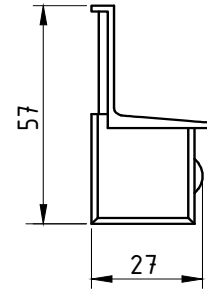
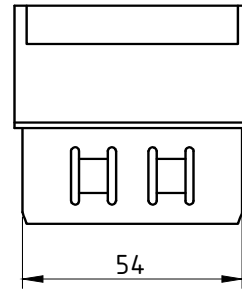
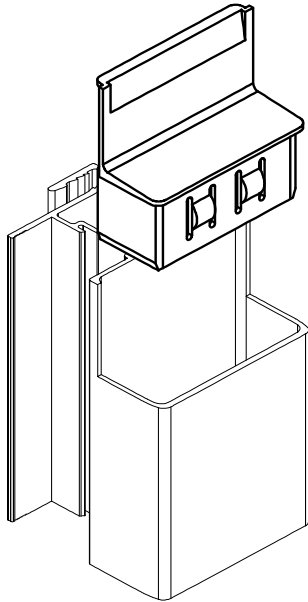

DETALHE DE APLICAÇÃO:
(sem escala)

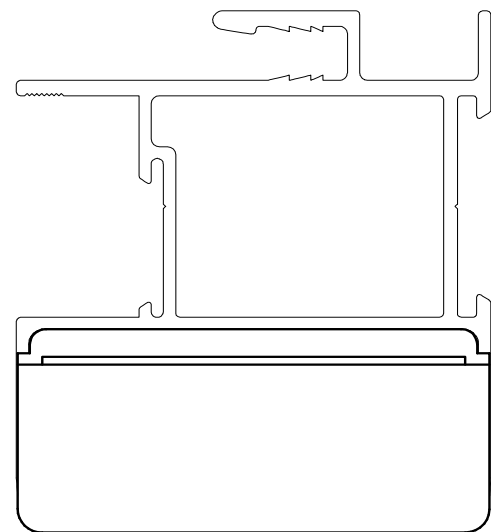

CARACTERÍSTICAS:

Componentes:	Matéria-prima:
Estrutura	Poliamida

Acabamento	
Preto	Branco

Embalagem	20 Peças
-----------	----------

CÓDIGO	ACABAMENTO
NYL-401	Preto
NYL-401NB	Branco

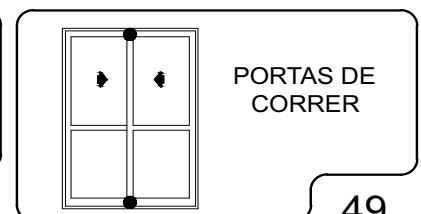

DIMENSÕES:
(escala 1:1)

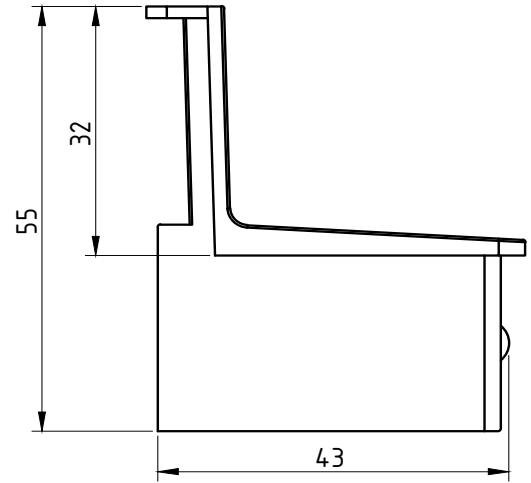
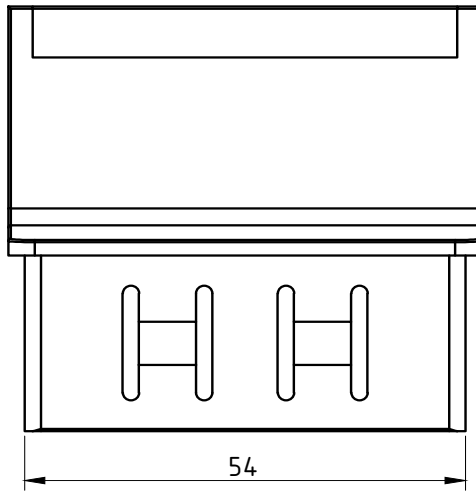

PERSPECTIVA SEM ESCALA:

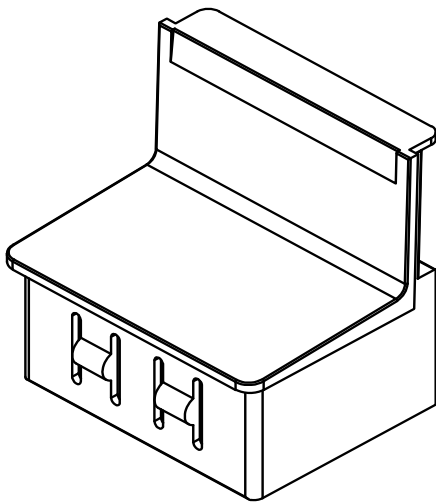

DETALHE DE APLICAÇÃO:
(sem escala)

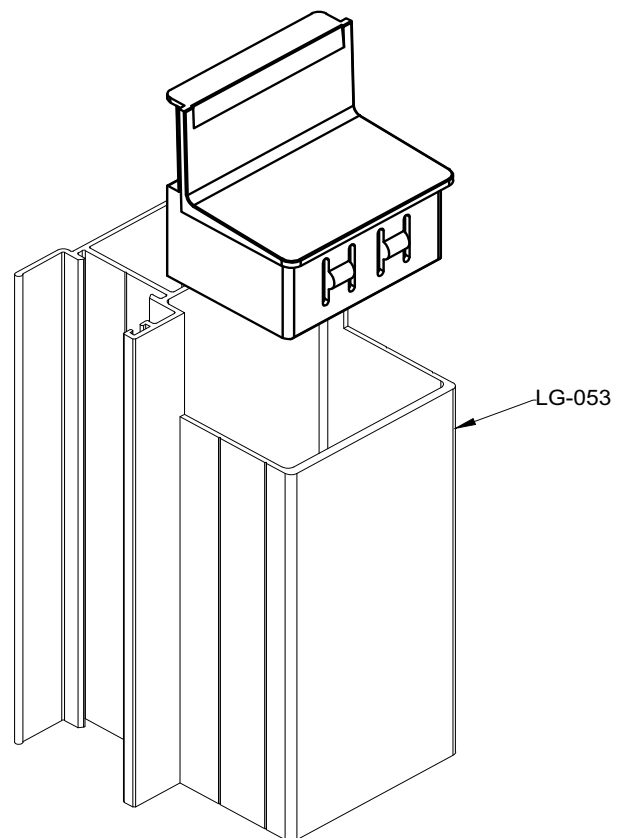

CARACTERÍSTICAS:

Componentes:	Matéria-prima:
Estrutura	Poliamida

Acabamento	Preto	Branco
------------	-------	--------

Embalagem	20 Peças
-----------	----------

CÓDIGO	ACABAMENTO
NYL-402	Preto
NYL-402NB	Branco





RECOBRIMENTO DA SOLEIRA CM-169

APLICAÇÃO:

ALUK 3.2®

Junho/2012

DIMENSÕES:
(escala 1:1)

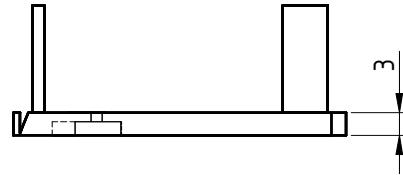
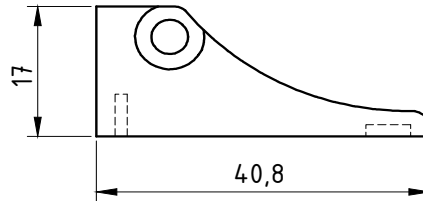

PERSPECTIVA:
(sem escala)

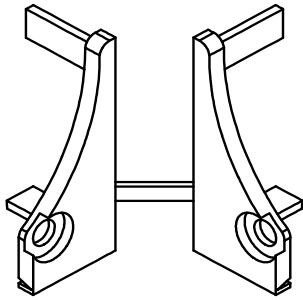

DETALHE DE APLICAÇÃO:
(sem escala)

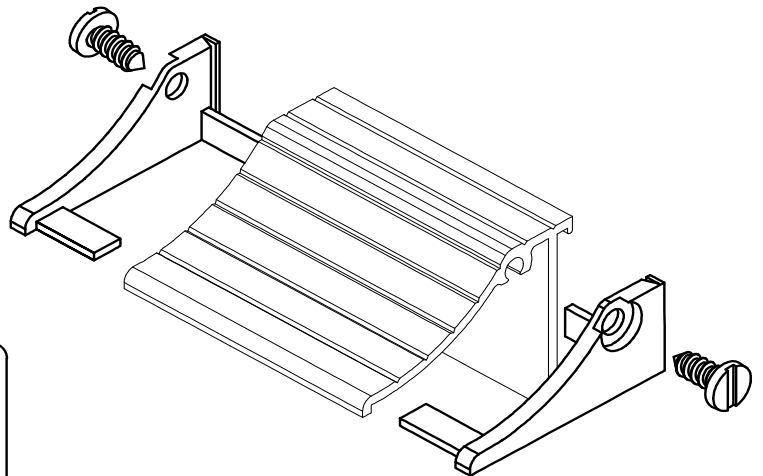

CARACTERÍSTICAS:

Componentes:	Matéria-prima:
Estrutura	Poliamida
Parafuso	Aço Inox

Acabamento	Preto / Branco
------------	----------------

Embalagem	10 Pares
-----------	----------

CÓDIGO	ACABAMENTO
NYL- 416	Preto
NYL- 416NB	Branco

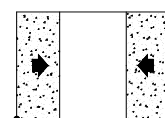

PORTAS
DE CORRER

DIMENSÕES:
(escala 1:2)

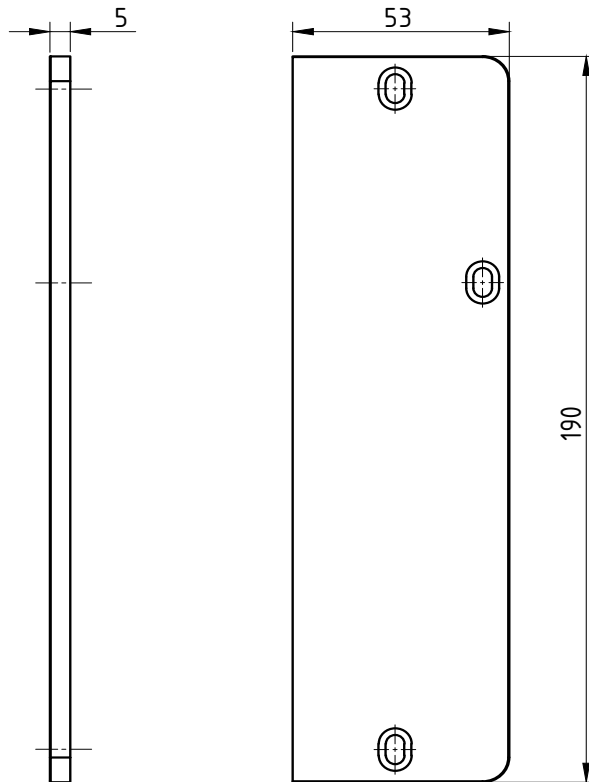

PERSPECTIVA:
(escala 1:2)

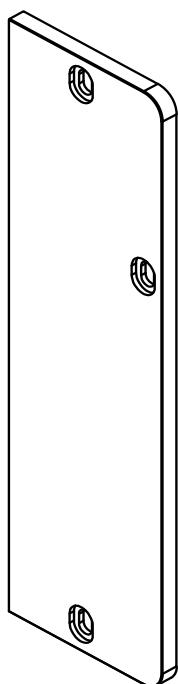

DETALHE DE APLICAÇÃO:
(sem escala)

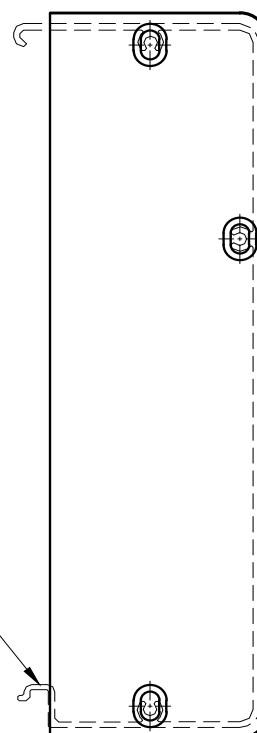

CARACTERÍSTICAS:

Componentes:	Matéria-prima:
Estrutura	Poliamida
Parafusos	Aço Inox

Acabamentos	
Preto	Branco

Embalagem	10 Pares
	60 Parafusos

CÓDIGO	ACABAMENTO
NYL- 481	Preto
NYL- 481NB	Branco

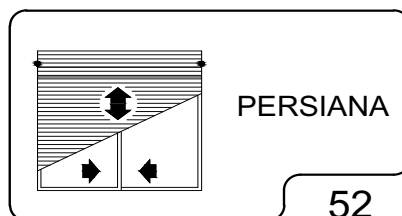

PERSIANA



PUXADOR PORTAS E JANELAS DE CORRER P/ FECHO CONCHA

APLICAÇÃO:

ALUK 3.2®

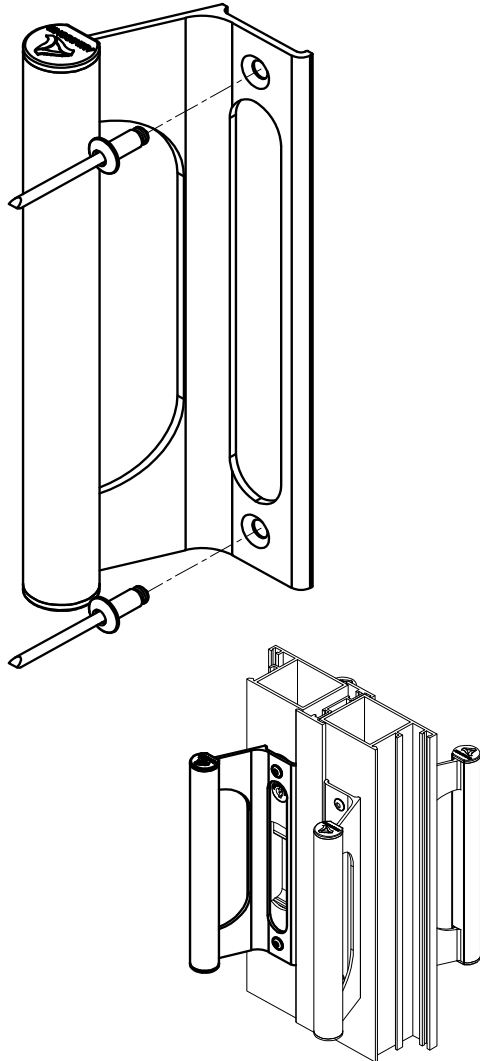

(escala 1:2)

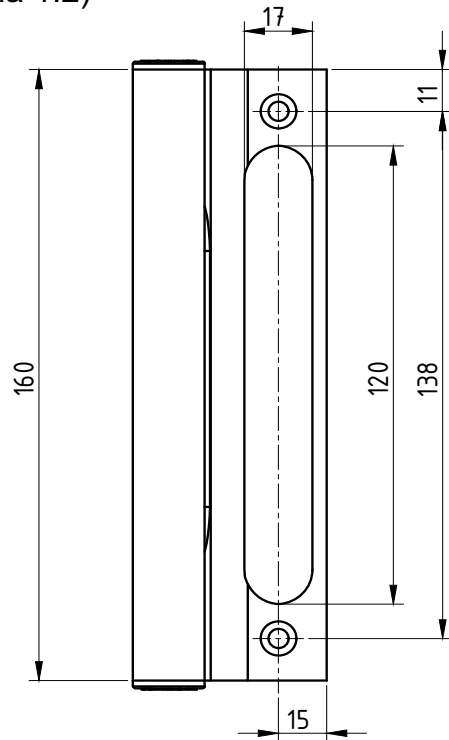

(escala 1:2)

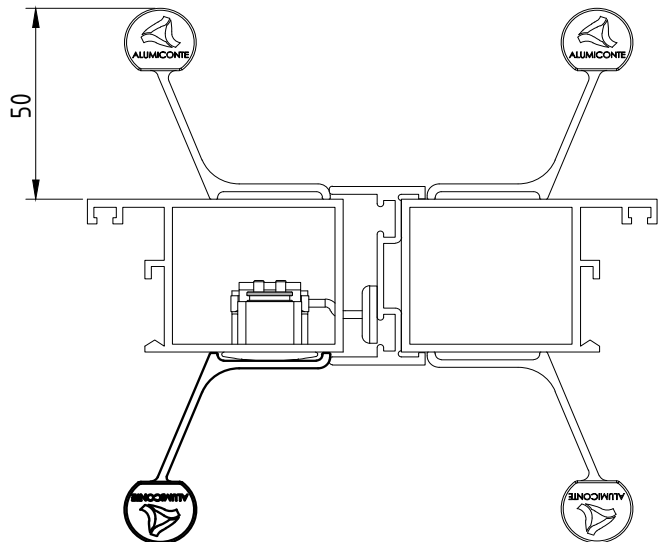

APLICAÇÃO NOS FECHOS

FEC-634	FEC-636
FEC-1035	FEC-1036
FEC-1037	FEC-1038

Componentes:	Matéria-prima:
Estrutura	Alumínio
Tampa	Poliamida
Rebite pop	Alumínio

Acabamento Anodizado e Pintado			
Preto	Branco	Fosco	Bronze

Embalagem	01 puxador
	02 rebites

CÓDIGO	ACABAMENTO
PUX-648	PRETO
PUX-6480	FOSCO
PUX-648EB	BRANCO
PUX-648BR	BRONZE

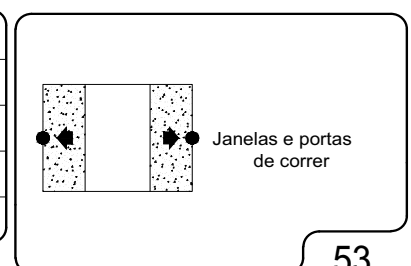

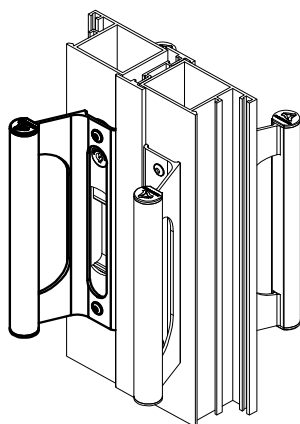
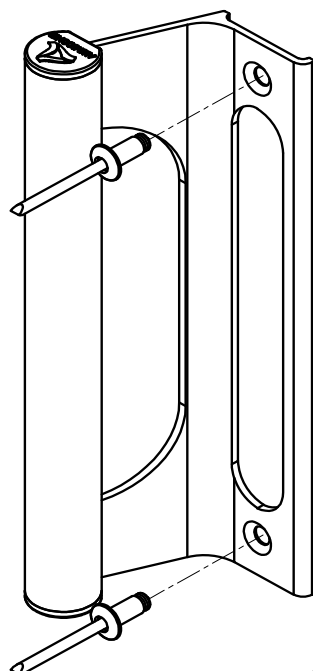

(escala 1:2)

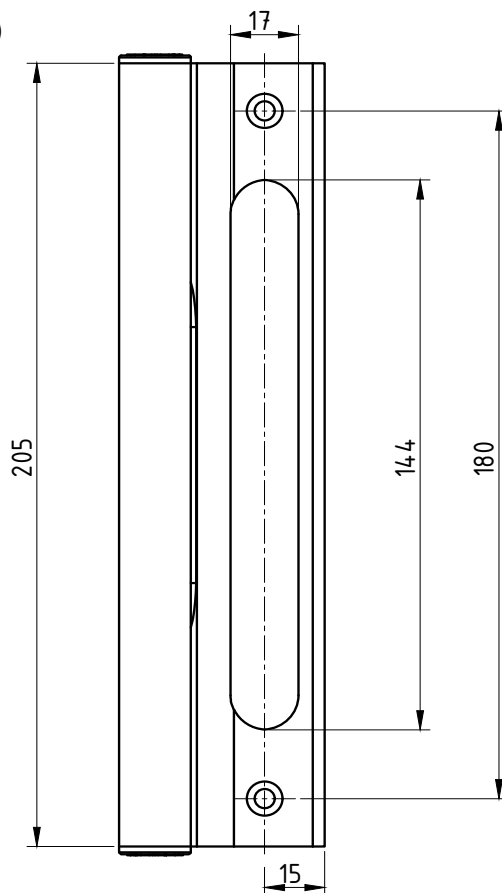

(escala 1:2)

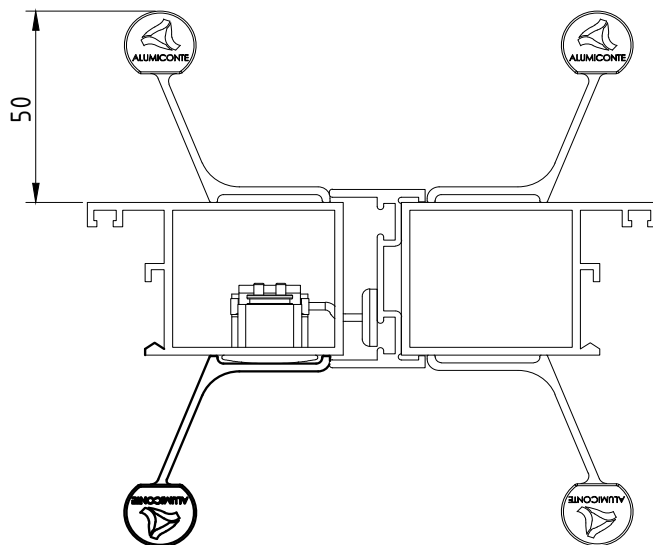

APLICAÇÃO NOS FECHOS

FEC-1041 FEC-1042
FEC-1039 FEC-1040

Componentes:	Matéria-prima:
Estrutura	Alumínio
Tampa	Poliamida
Rebite pop	Alumínio

Acabamento Anodizado e Pintado			
Preto	Branco	Fosco	Bronze

Embalagem	01 puxador
	02 rebites

CÓDIGO	ACABAMENTO
PUX-649	PRETO
PUX-6490	FOSCO
PUX-649EB	BRANCO
PUX-649BR	BRONZE

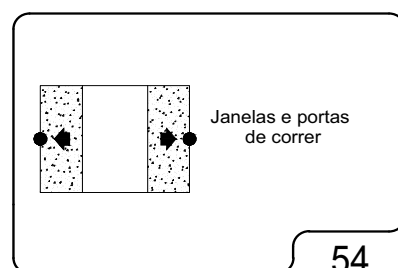

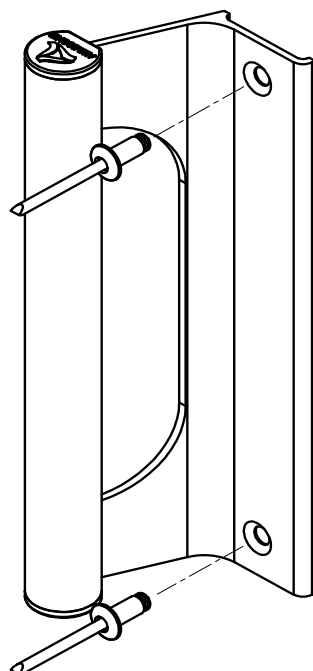

(escala 1:2)

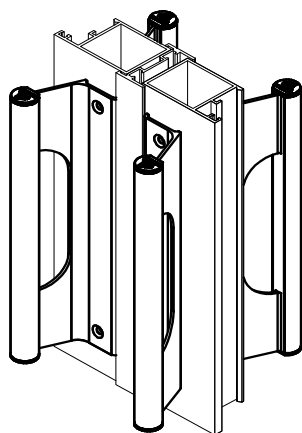
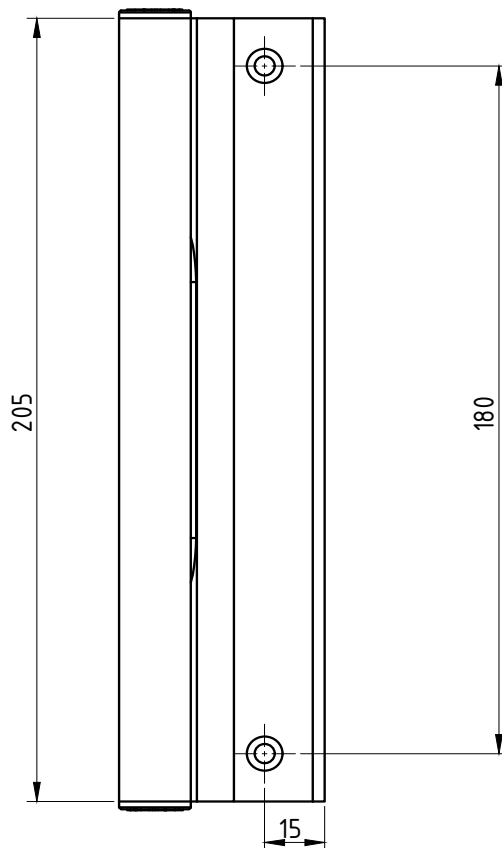

(escala 1:2)

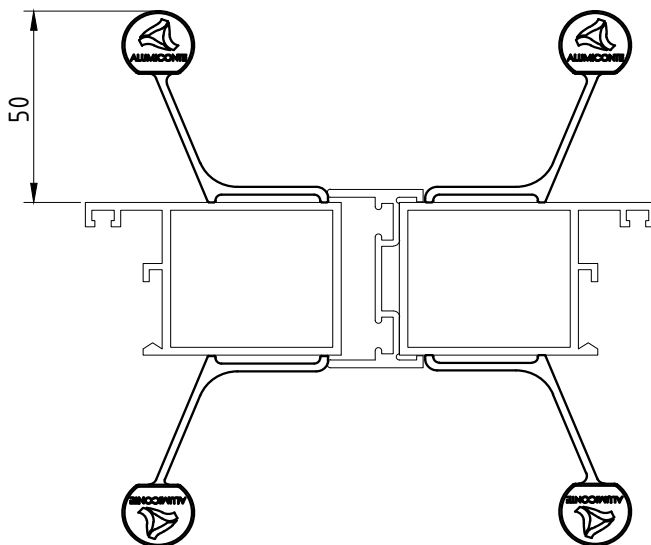

Componentes:	Matéria-prima:
Estrutura	Alumínio
Tampa	Poliamida
Rebite pop	Alumínio

Acabamento Anodizado e Pintado			
Preto	Branco	Fosco	Bronze

Embalagem	01 puxador
	02 rebites

CÓDIGO	ACABAMENTO
PUX-654	PRETO
PUX-6540	FOSCO
PUX-654EB	BRANCO
PUX-654BR	BRONZE

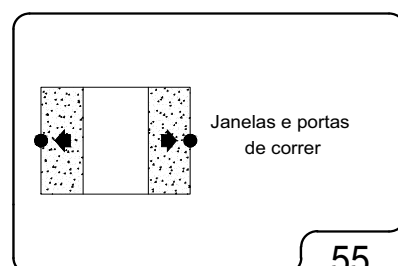

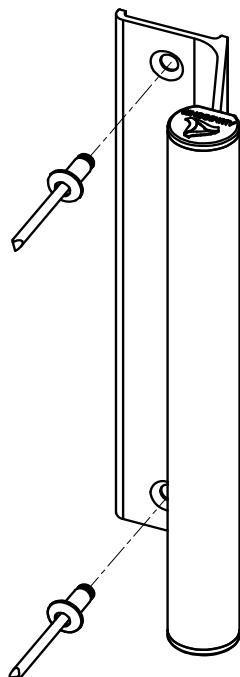

(escala 1:2)

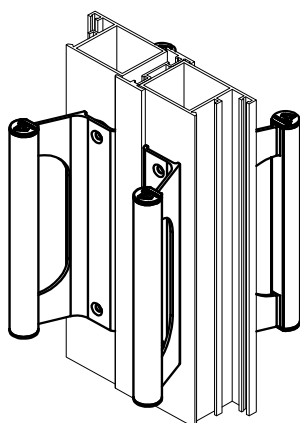
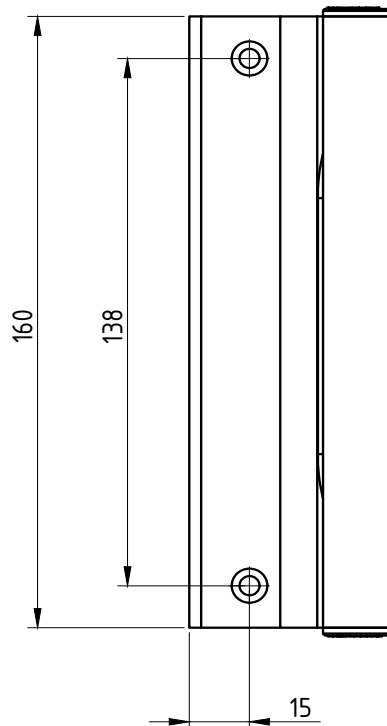

(escala 1:2)

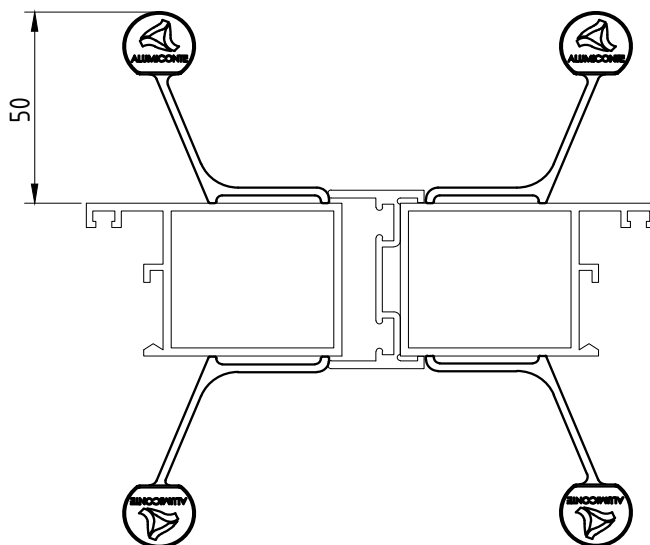

Componentes:	Matéria-prima:
Estrutura	Alumínio
Tampa	Poliamida
Rebite pop	Alumínio

Acabamento Anodizado e Pintado			
Preto	Branco	Fosco	Bronze

Embalagem	01 puxador
	02 rebites

CÓDIGO	ACABAMENTO
PUX-650	PRETO
PUX-6500	FOSCO
PUX-650EB	BRANCO
PUX-650BR	BRONZE

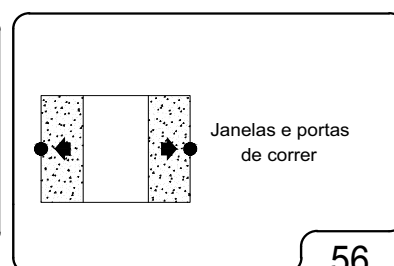

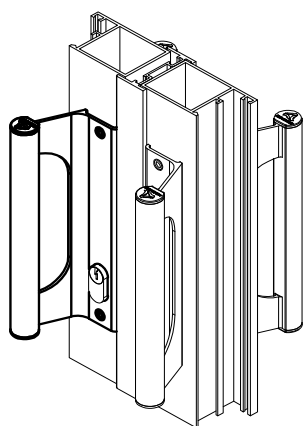
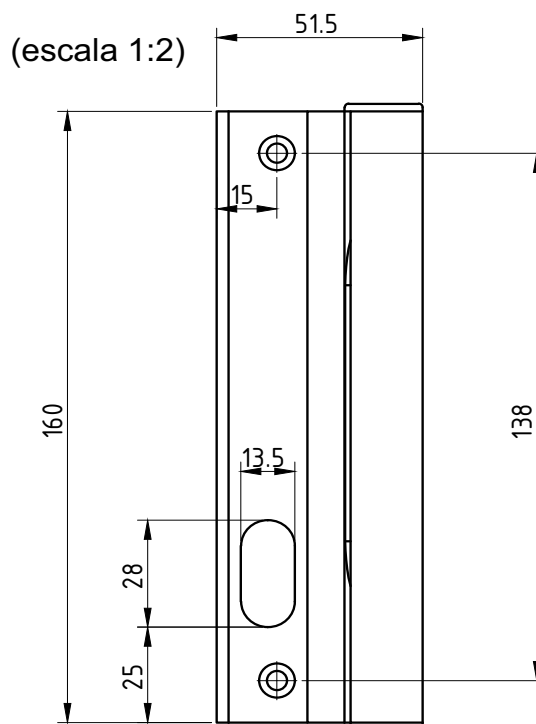
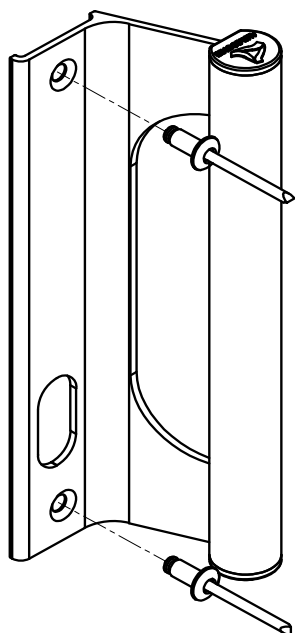

(escala 1:2)

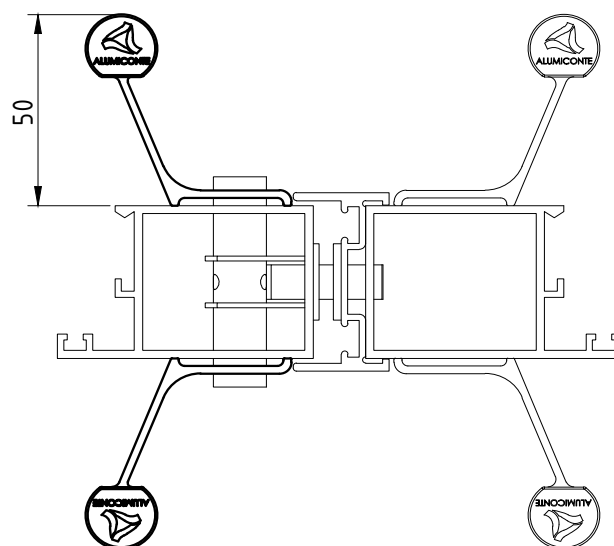

Componentes:	Matéria-prima:
Estrutura	Alumínio
Tampa	Poliamida
Rebite pop	Alumínio

Acabamento Anodizado e Pintado			
Preto	Branco	Fosco	Bronze

Embalagem	01 puxador
	02 rebites

CÓDIGO	ACABAMENTO
PUX-652(direito)	PRETO
PUX-6520(direito)	FOSCO
PUX-652EB(direito)	BRANCO
PUX-652BR(direito)	BRONZE
PUX-653(esq.)	PRETO
PUX-6530(esq.)	FOSCO
PUX-653EB(esq.)	BRANCO
PUX-653BR(esq.)	BRONZE

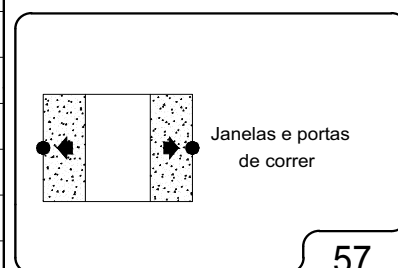

DIMENSÕES:
(escala 1:1)

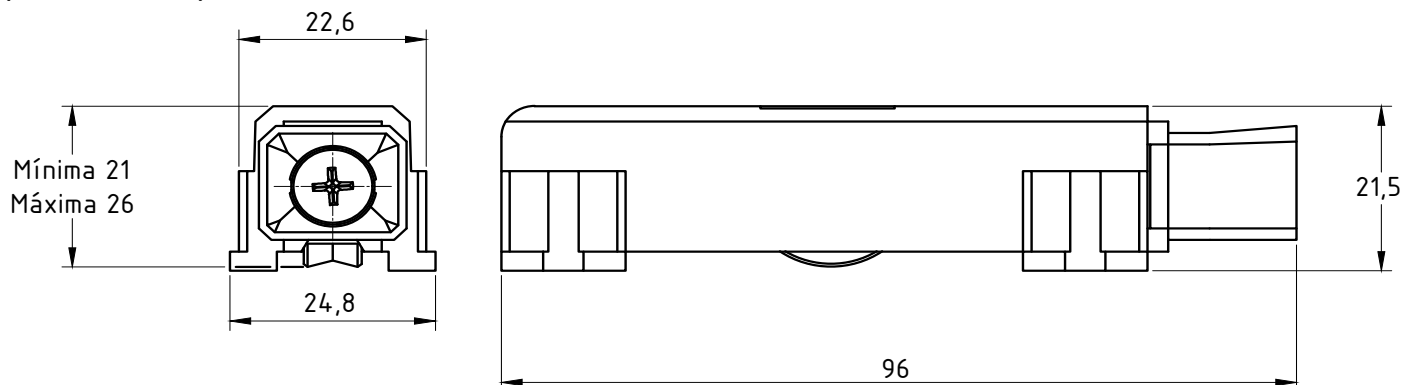

PERSPECTIVA:
(escala 1:1)

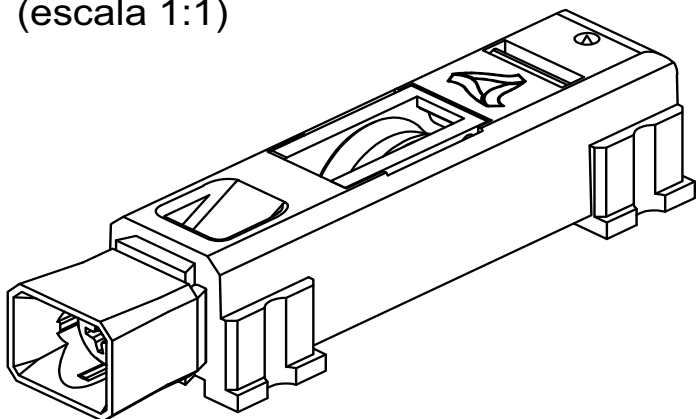

DETALHE DE APLICAÇÃO:
(sem escala)

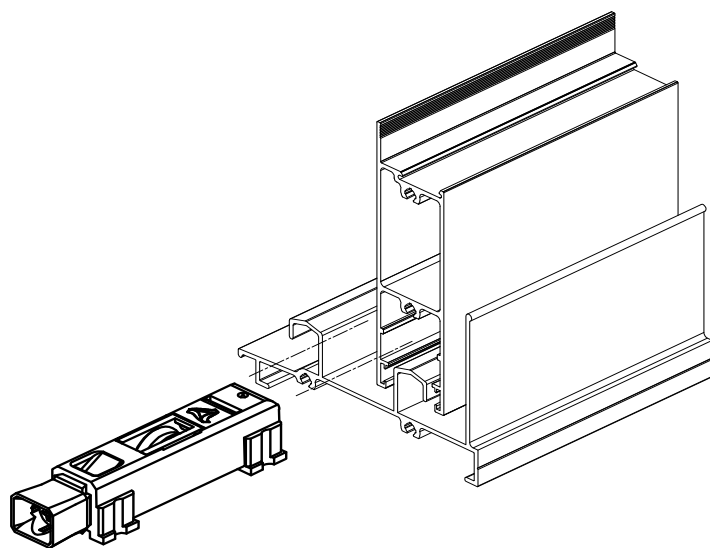

CARACTERÍSTICAS:

Componentes:	Matéria-prima:
Cavalete	Poliamida
Suporte Para Roda	Zamac Bicromatizado
Rolamento	Importado
Capa	Poliamida
Eixo	Latão
Parafusos	Aço Inox

Código:	Carga Máxima:
ROL 468	20 kg Por Roldana

Embalagem	20 Roldanas
-----------	-------------

CÓDIGO	ACABAMENTO
ROL- 468	Preto

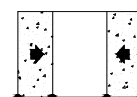

JANELAS E
PORTAS
DE CORRER



ROLDANA DUPLA COM ROLAMENTO E REGULAGEM

APLICAÇÃO:

ALUK 3.2®

DIMENSÕES:
(Sem escala)

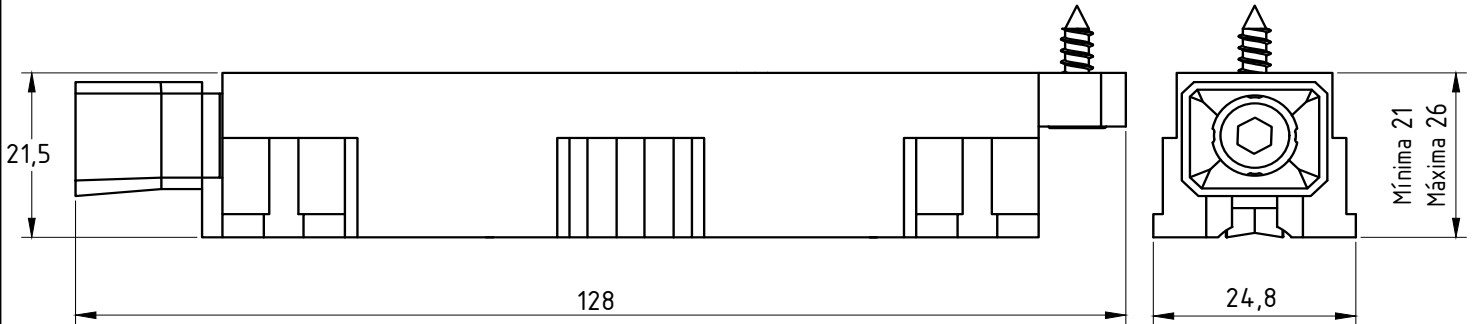

PERSPECTIVA:
(Sem escala)

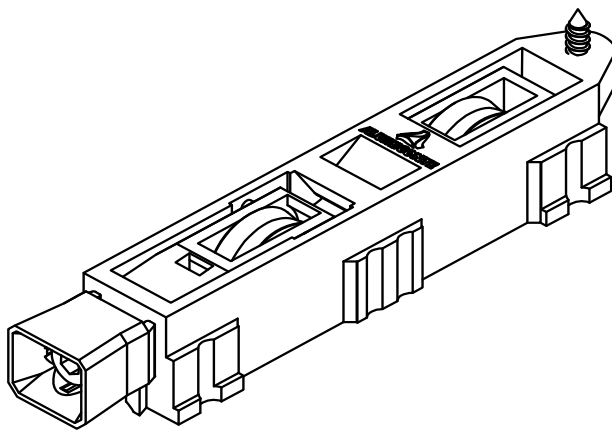

DETALHE DE APLICAÇÃO:
(sem escala)

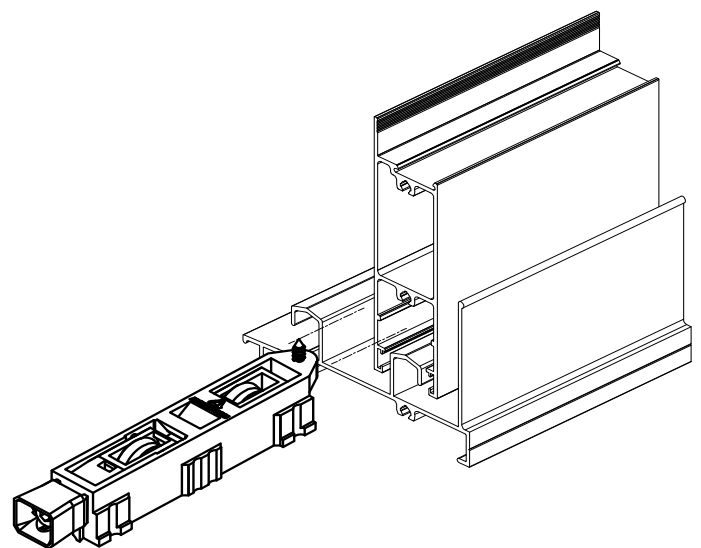

CARACTERÍSTICAS:

Componentes:	Matéria-prima:
Cavalete	Poliamida
Suporte Para Roda	Poliamida fibra
Rolamentos	Importado
Capas	Poliamida
Eixos	Latão
Parafusos	Aço Inox

Código:	Carga Máxima:
ROL 413	40 kg Por Roldana

Embalagem	20 Roldanas
-----------	-------------

CÓDIGO	ACABAMENTO
ROL- 413	Preto

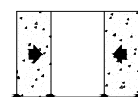

PORTAS DE CORRER

PERSPECTIVA:
(Escala 1:2)

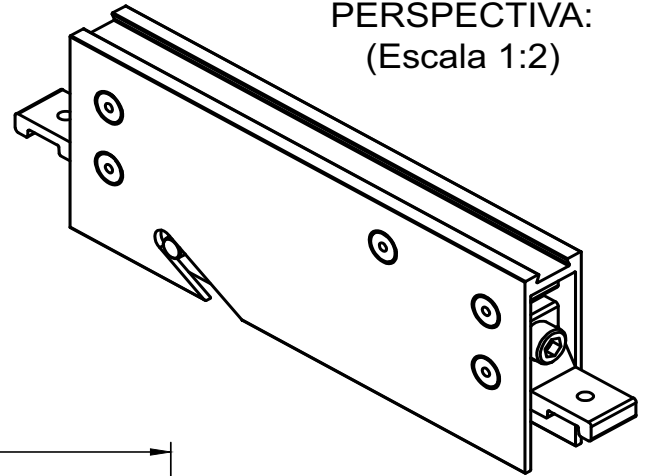

DIMENSÕES:
(Escala 1:2)

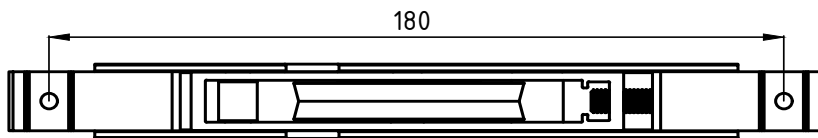
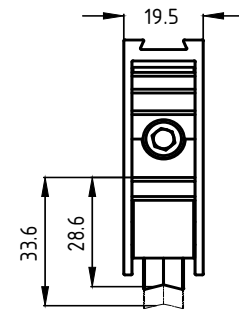
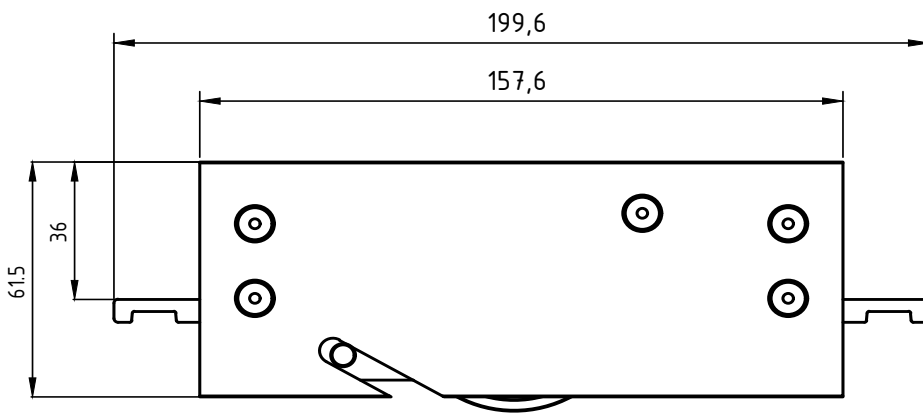

DETALHE DE APLICAÇÃO:
(sem escala)

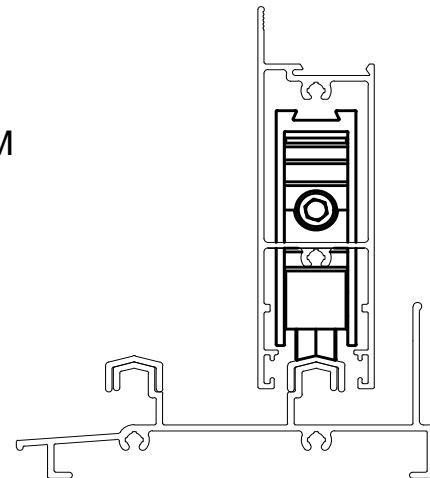

DETALHE DE USINAGEM
PG. 18.34

CARACTERÍSTICAS:

Componentes:	Matéria-prima:
Estrutura	Alumínio
Rolamento	Aço
Roda	Poliamida 30% FV
Eixos	Alumínio/aço inox
Parafusos	Aço inox

Embalagem	01 Roldana
-----------	------------

CÓDIGO	CARGA MAX.
ROL- 470	130 Kg/folha

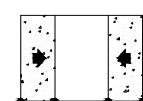

PORTAS
DE CORRER

DIMENSÕES:
(Escala 1:2)

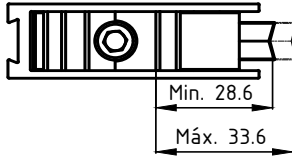

PERSPECTIVA:
(Escala 1:2)

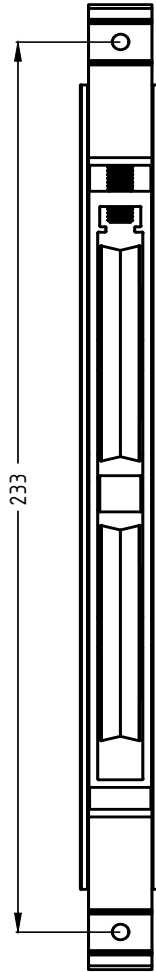
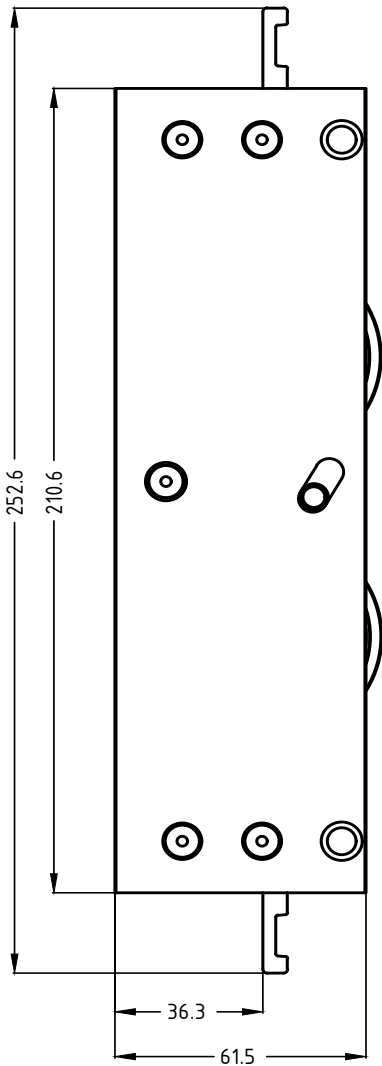
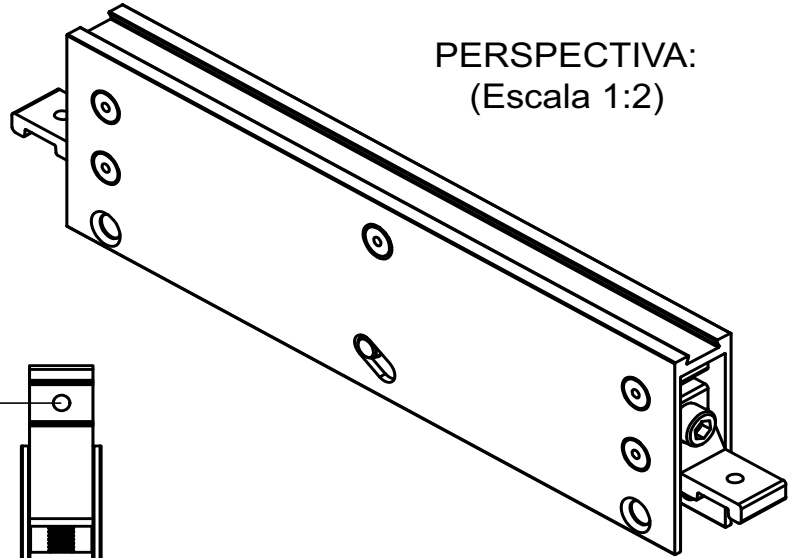

**DETALHE DE USINAGEM
PG. 18.34**

DETALHE DE APLICAÇÃO:
(sem escala)

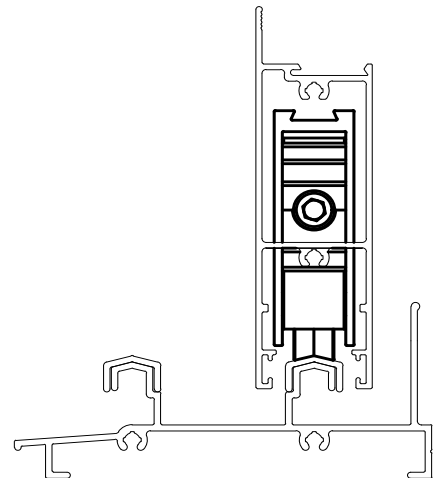

CARACTERÍSTICAS:

Componentes:	Matéria-prima:
Estrutura	Alumínio
Rolamentos	Aço
Rodas	Poliamida 30% FV
Eixos	Alumínio/aço inox
Parafusos	Aço inox

Embalagem	01 Roldana
-----------	------------

CÓDIGO	CARGA MAX.
ROL- 471	260 Kg/folha

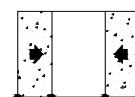

**PORTAS
DE CORRER**

Setembro/2018

S/ESCALA

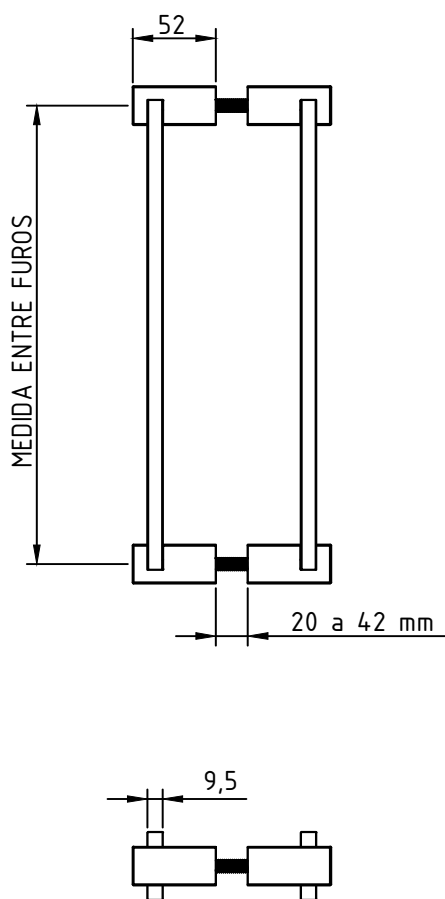

PERSPECTIVA
S/ESCALA

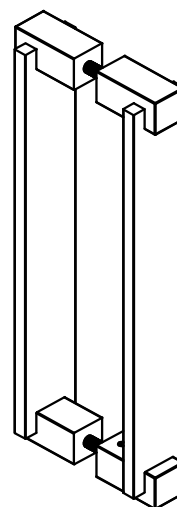

CÓDIGO	ACAB./TAM. entre furos
PUX1030BC	BRANCO/300 mm
PUX1030FS	PRATA/300 mm
PUX1030PT	PRETO/300 mm
PUX1050BC	BRANCO/500 mm
PUX1050FS	PRATA/500 mm
PUX1050PT	PRETO/500 mm
PUX1070BC	BRANCO/700 mm
PUX1070FS	PRATA/700 mm
PUX1070PT	PRETO/700 mm
PUX1090BC	BRANCO/900 mm
PUX1090FS	PRATA/900 mm
PUX1090PT	PRETO/900 mm
PUX1110BC	BRANCO/1100 mm
PUX1110FS	PRATA/1100 mm
PUX1110PT	PRETO/1100 mm

Componentes:	Matéria-prima:
Estrutura	Alumínio
Parafusos	Aço Inox
Barra roscada	Aço Zincado

Acabamento Pintado		
Branco	Prata	Preto

Embalagem	01 par de puxadores
	01 Kit de fixação



S/ESCALA

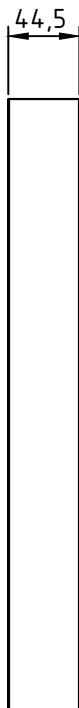
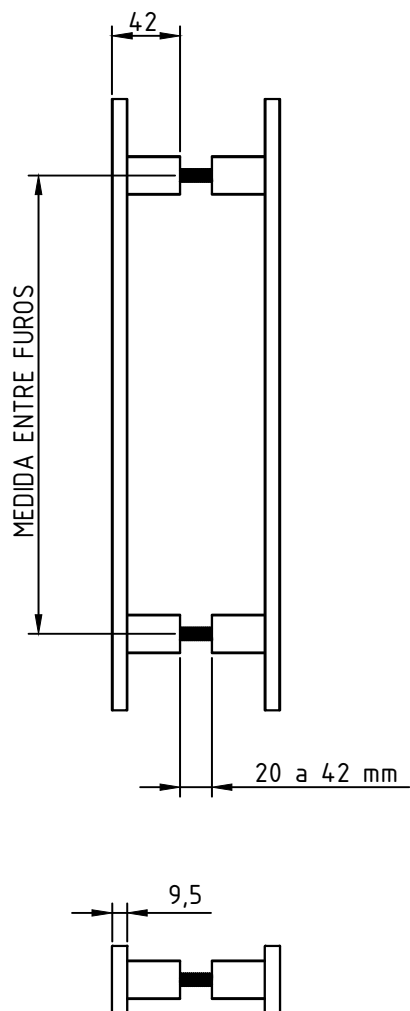

PERSPECTIVA S/ESCALA

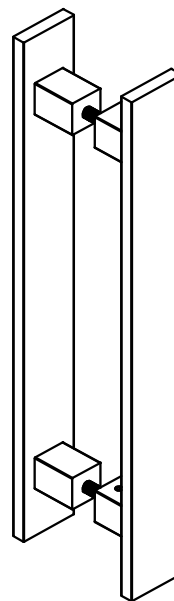

CÓDIGO	ACAB./TAM. entre furos
PUX2030BC	BRANCO/300 mm
PUX2030FS	PRATA/300 mm
PUX2030PT	PRETO/300 mm
PUX2050BC	BRANCO/500 mm
PUX2050FS	PRATA/500 mm
PUX2050PT	PRETO/500 mm
PUX2070BC	BRANCO/700 mm
PUX2070FS	PRATA/700 mm
PUX2070PT	PRETO/700 mm
PUX2090BC	BRANCO/900 mm
PUX2090FS	PRATA/900 mm
PUX2090PT	PRETO/900 mm
PUX2110BC	BRANCO/1100 mm
PUX2110FS	PRATA/1100 mm
PUX2110PT	PRETO/1100 mm

Componentes:	Matéria-prima:
Estrutura	Alumínio
Parafusos	Aço Inox
Barra roscada	Aço Zincado

Acabamento Pintado		
Branco	Prata	Preto

Embalagem	01 par de puxadores
	01 Kit de fixação



Setembro/2018

S/ESCALA

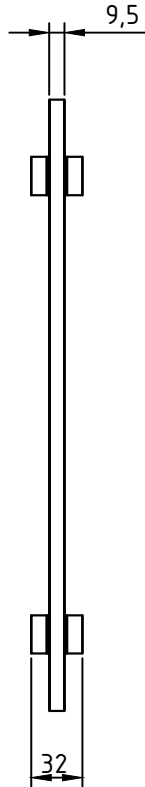
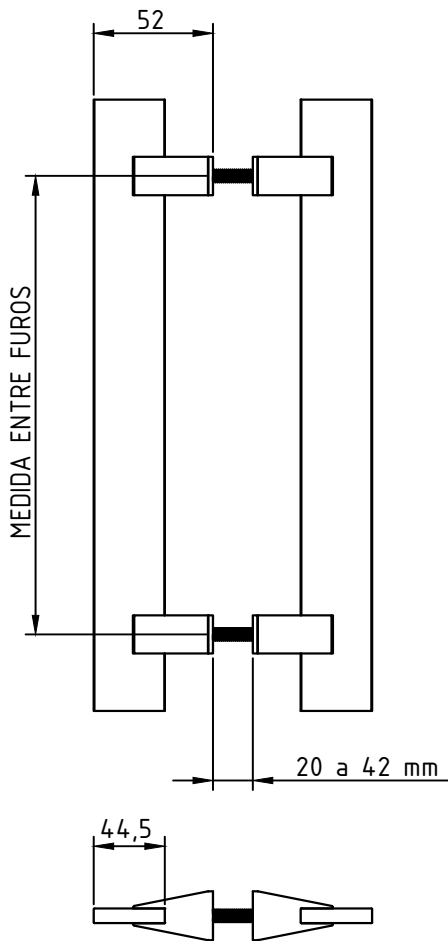

PERSPECTIVA
S/ESCALA

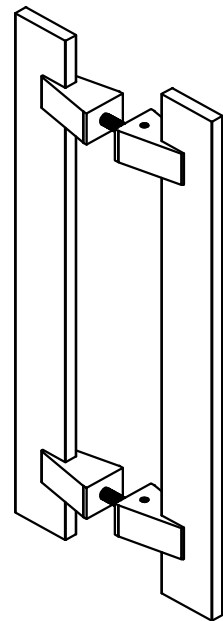

CÓDIGO	ACAB./TAM. entre furos
PUX3030BC	BRANCO/300 mm
PUX3030FS	PRATA/300 mm
PUX3030PT	PRETO/300 mm
PUX3050BC	BRANCO/500 mm
PUX3050FS	PRATA/500 mm
PUX3050PT	PRETO/500 mm
PUX3070BC	BRANCO/700 mm
PUX3070FS	PRATA/700 mm
PUX3070PT	PRETO/700 mm
PUX3090BC	BRANCO/900 mm
PUX3090FS	PRATA/900 mm
PUX3090PT	PRETO/900 mm
PUX3110BC	BRANCO/1100 mm
PUX3110FS	PRATA/1100 mm
PUX3110PT	PRETO/1100 mm

Componentes:	Matéria-prima:
Estrutura	Alumínio
Parafusos	Aço Inox
Barra roscada	Aço Zincado

Acabamento Pintado		
Branco	Prata	Preto

Embalagem	01 par de puxadores
	01 Kit de fixação



ATENÇÃO!
VERIFICAR A TENSÃO CORRETA (V).

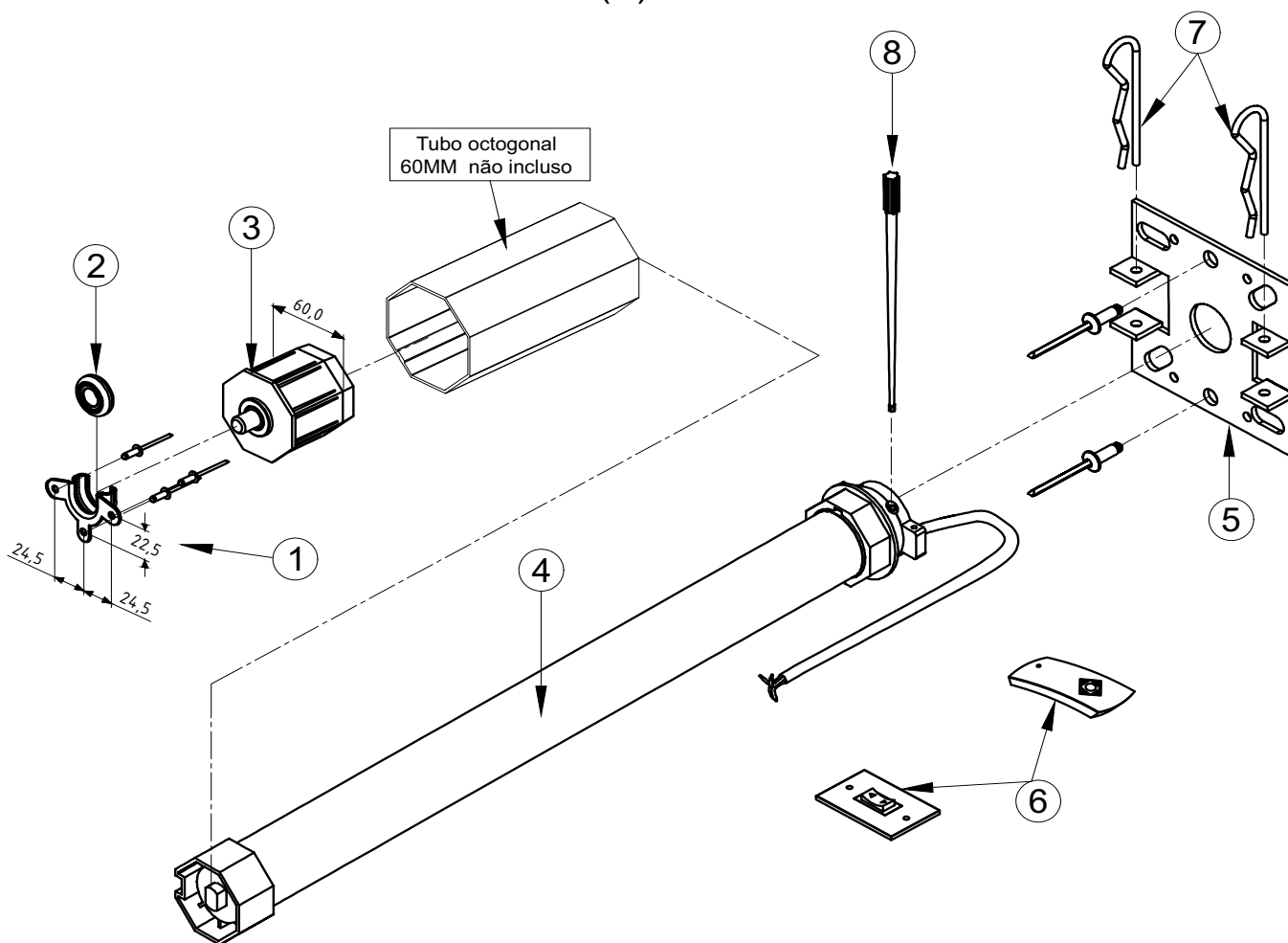

PESO MÁXIMO DA PERSIANA: 60Kg

CARACTERÍSTICAS:

N:	Componentes:	Matéria-prima:
1	Mancal do Recolhedor	Aço
2	Rolamento do Mancal	Aço / Poliamida
3	Ponteira de Eixo 60mm	Aço / ABS
4	Motor	Aço / Poliamida
5	Suporte	Aço
6	controle ou interruptor	Poliamida
7	Grampo	Aço
8	Chave regulagem	Poliamida

Componentes p/ Fixação:	Matéria-prima:
Parafusos	Aço Inox
Rebites	Alumínio

Acabamentos:	
Preto	

Embalagem	1 Conjunto
-----------	------------

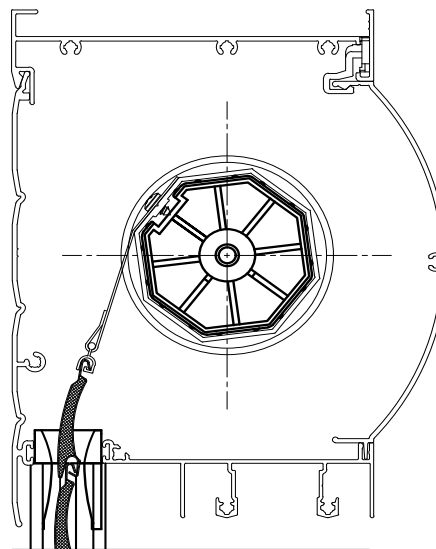

Código	DESCRIÇÃO
MA-R40-220	C/C-220V
MA-R40-110	C/C-110V
MA-40-220	C/I-220V
MA-40-110	C/I-110V

Portas e Janelas

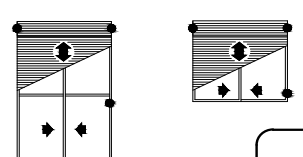

PERSPECTIVA:
(escala 1:1)

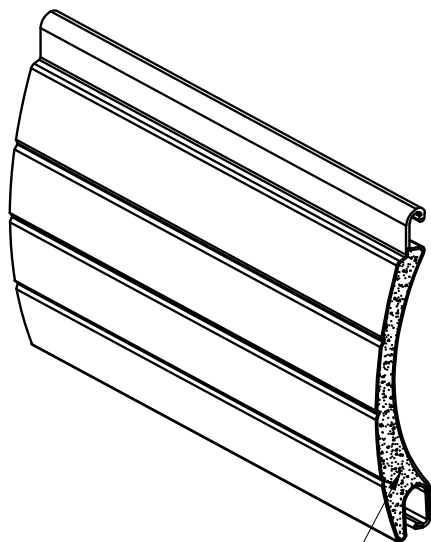

Poliuretano
injetado

DIMENSÕES:
(escala 1:1)

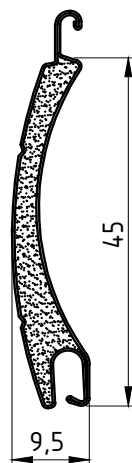

DETALHE DE APLICAÇÃO:
(sem escala)

NYL - 447

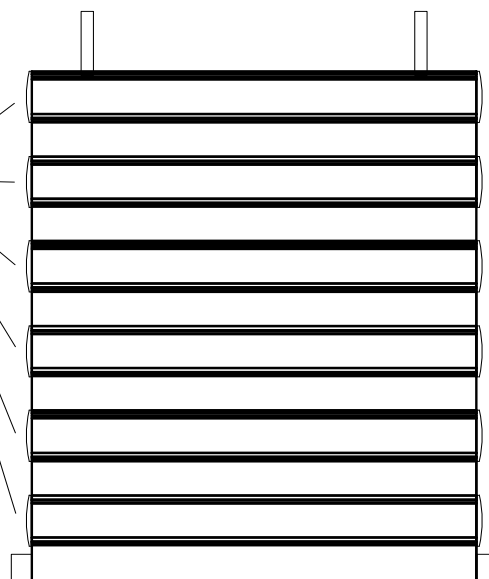

DIMENSÕES PARA ROLO DA ESTEIRA

Altura em Metro Linear	1300	1600	2400	2800
Diametro do Rolo da Esteira	124	128	154	158

Dimensões considerando eixo 40mm e perfil terminal.
Medidas em mm.

CARACTERÍSTICAS:

Componentes:	Matéria-prima:
Estrutura	Alumínio 3105 H46

Peso (Kg/m ²)	Aproxim. 2,5 Kg/m ²
Densidade de espuma	70-90 kg/m ³

Embalagem	Barras de 5.8 metros Pacotes de 60 peças
-----------	---

ORIENTAÇÃO DE MONTAGEM PARA NÃO OCORRER O DESALINHAMENTO DAS PERSIANAS DURANTE A MOVIMENTAÇÃO DA ESTEIRA.

CÓDIGO	ACABAMENTO
VZP-0310BC	Branca / Vent.
VZP-1100BC	Branca / Cega
VZP-0140BZ	Bronze / Vent.
VZP-1120BZ	Bronze / Cega
VZP-0320FS	Prata / Vent.
VZP-1110FS	Prata / Cega
VZP-0330PT	Preta / Vent.
VZP-1130PT	Preta / Cega

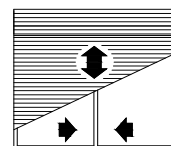

PERSIANAS

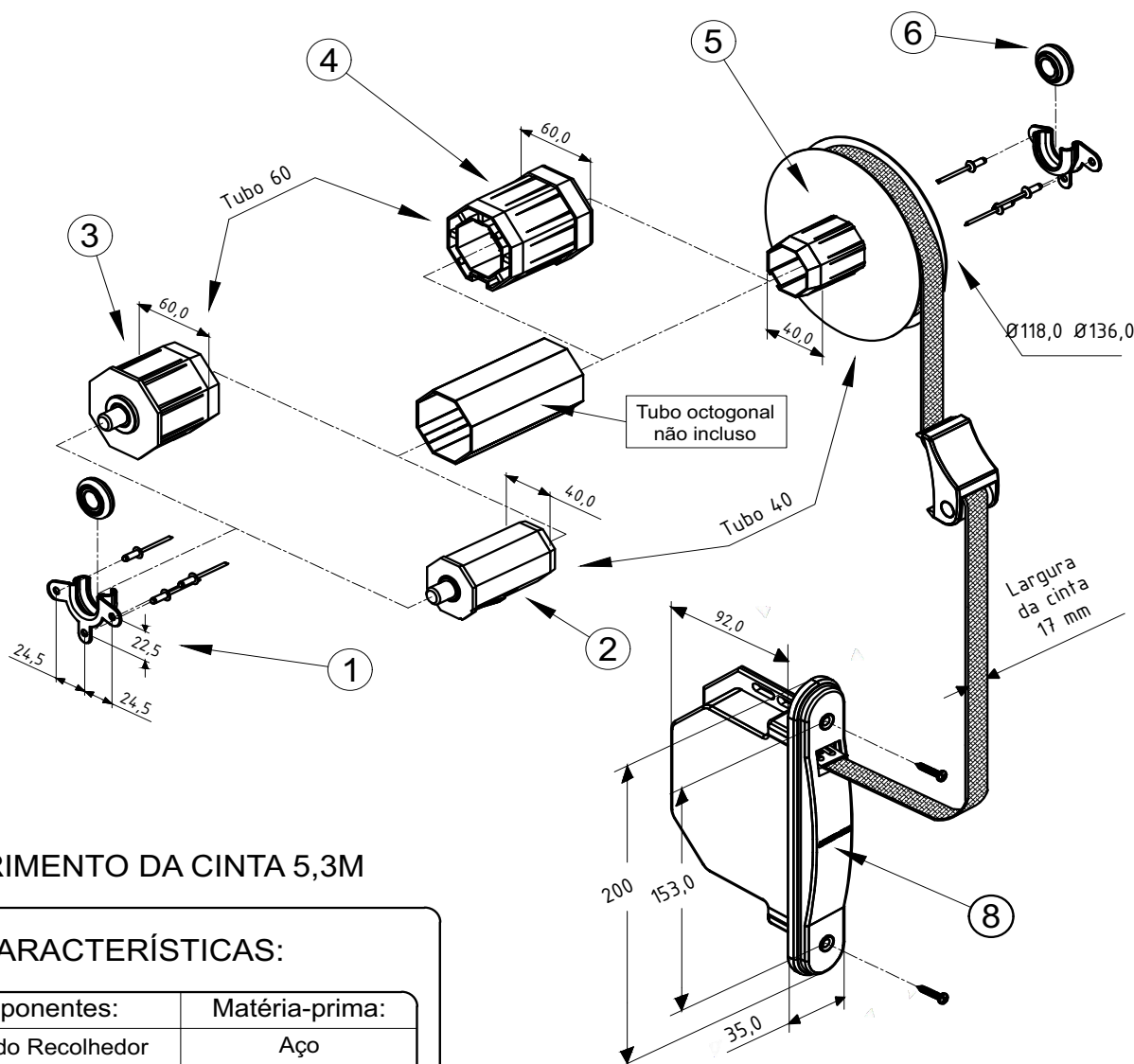

COMPRIMENTO DA CINTA 5,3M

CARACTERÍSTICAS:

N:	Componentes:	Matéria-prima:
1	Mancal do Recolhedor	Aço
2	Ponteira de Eixo 40mm	Aço / ABS
3	Ponteira de Eixo 60mm	Aço / ABS
4	Adaptador p/ Tubo 60mm	ABS
5	Polia Ø118,0	Aço / ABS
	Polia Ø136,0	Aço / ABS
6	Rolamento do Mancal	Aço / Poliamida
7	Guia da Cinta	Poliamida
8	Máquina c/ Espelho e Caixa	ABS / Aço

Componentes p/ Fixação:	Matéria-prima:
Parafusos	Aço Inox
Rebites	Alumínio

Acabamentos:	
Preto	Branco

Embalagem	1 Conjunto
-----------	------------



OBS: Detalhamento de montagem ver nas paginas 12.04 12.05

Código Preto	Código Branco	Tubo (mm)	Polia (mm)	Aplicação
REC - 120	REC - 120 EB	40	Ø118,0	Janela
REC - 121	REC - 121EB	40	Ø136,0	Porta
REC - 122	REC - 122 EB	60	Ø118,0	Janela
REC - 123	REC - 123 EB	60	Ø136,0	Porta

PERSIANA
Portas e Janelas
Peso Máximo: 12Kg
Altura máxima da Porta: 2,40 m

Abril/2017

Fixação do
Mancal

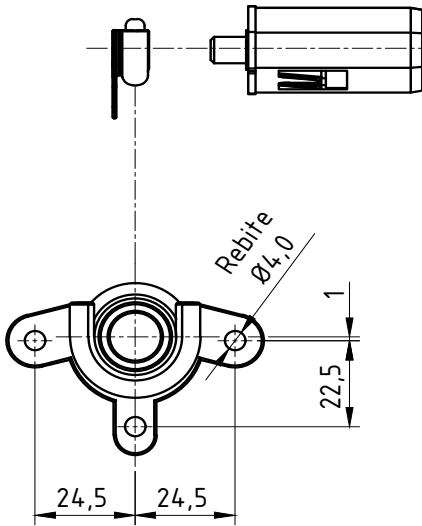

Tubo octogonal
não incluso

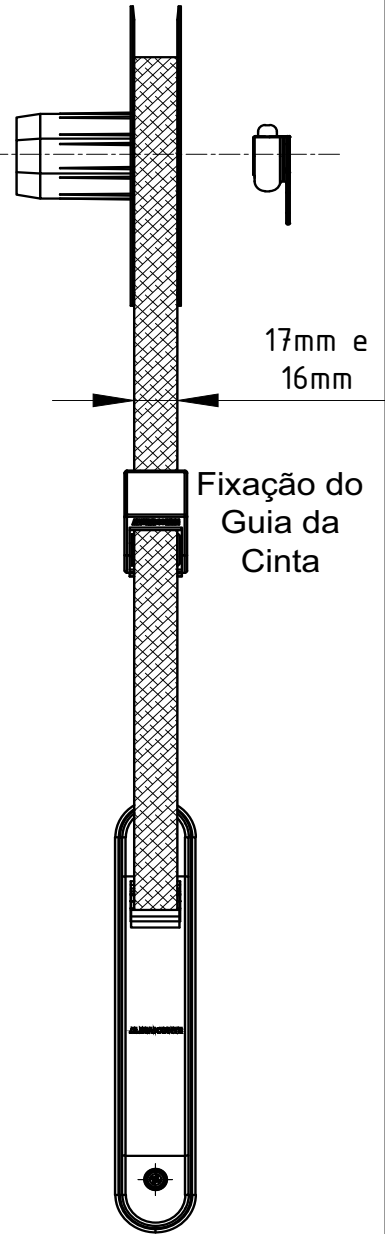
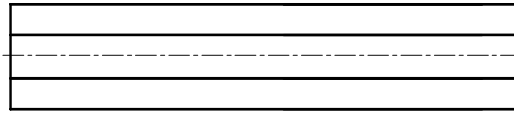

Corte do Tubo

- Tubo 40

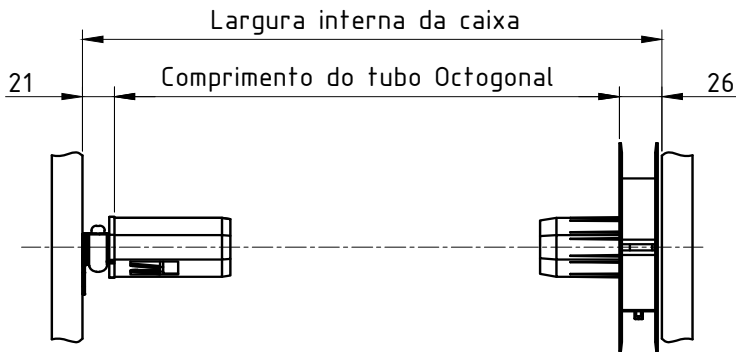

- Tubo 60

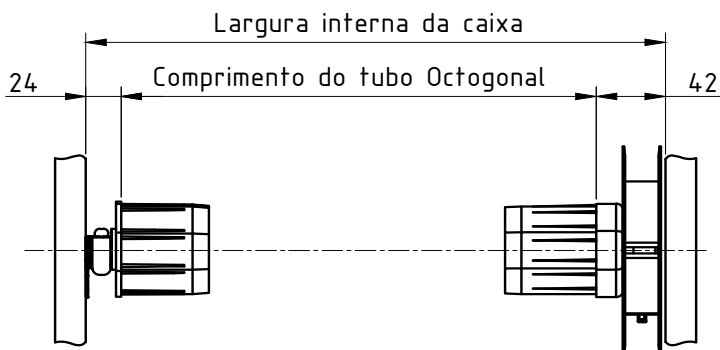

(2x) Fixação das Máquinas

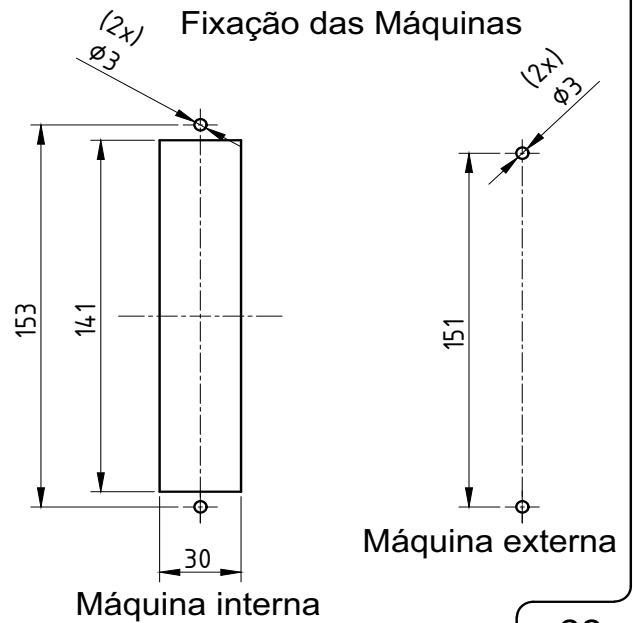

INSTRUÇÕES DE MONTAGEM
DO RECOLHEDOR

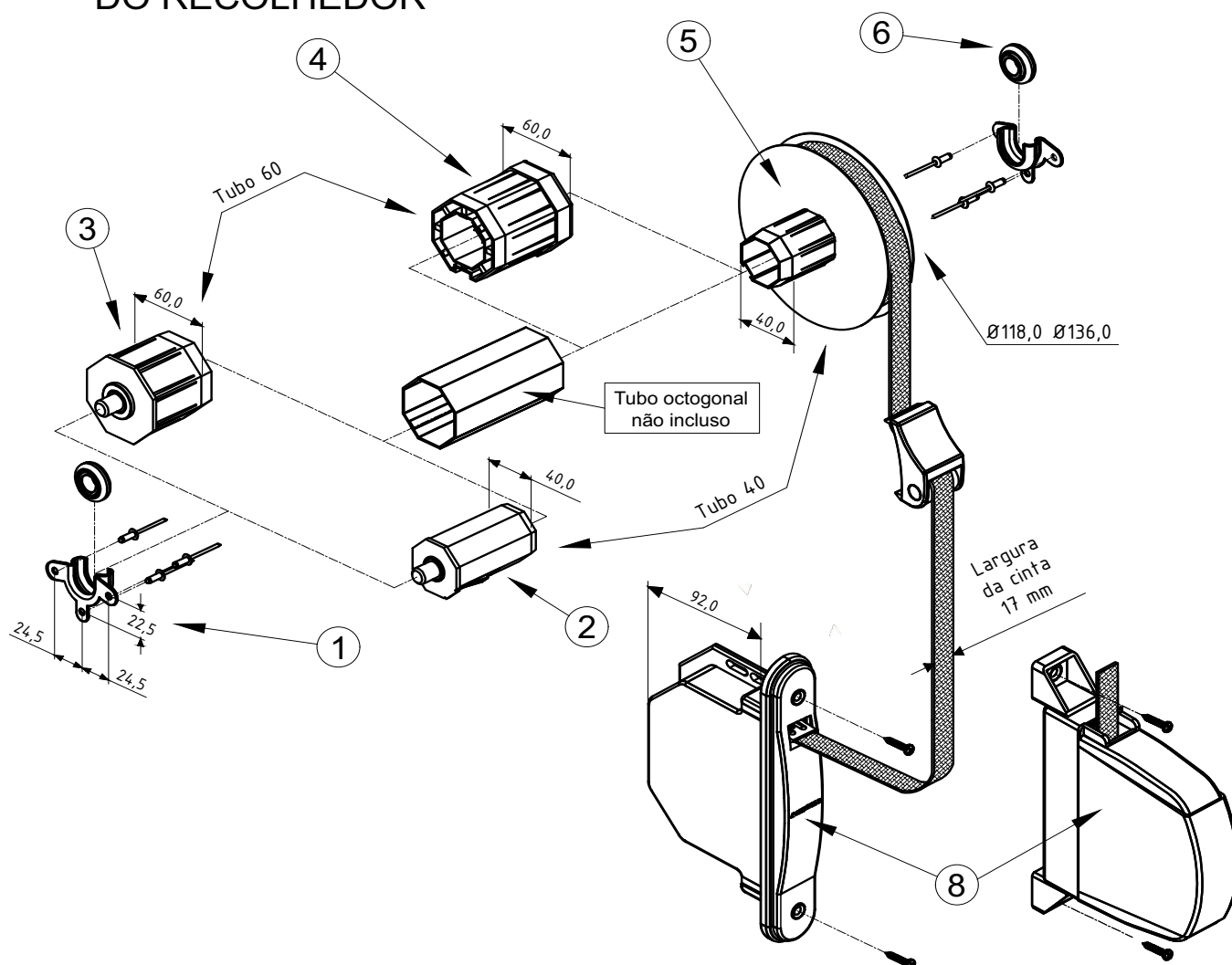

Instruções

- Fixar a Máquina interna ou externa (8) na esquadria;
- Prender os Mancais (1) centralizados na caixa;
- Montar a Polia (5), o Adaptador (4) para tubos de 60mm, o Tubo e a Ponteira (2, 3 ou 9) de acordo com a aplicação e a largura da caixa;
- Passar a Cinta (7) pela Guia (6) e pela Tampa da esquadria, fixá-la na Polia (5);
- Enrolar a Cinta (7) na polia (5) até que a máquina (8) fique toda tensionada;
- Deixar de 3 a 4 voltas de cinta (7) na máquina para garantir o bom funcionamento do recolhedor;
- 7°- Fixar a esteira no tubo octogonal.

DETALHE DE APLICAÇÃO:
(sem escala)

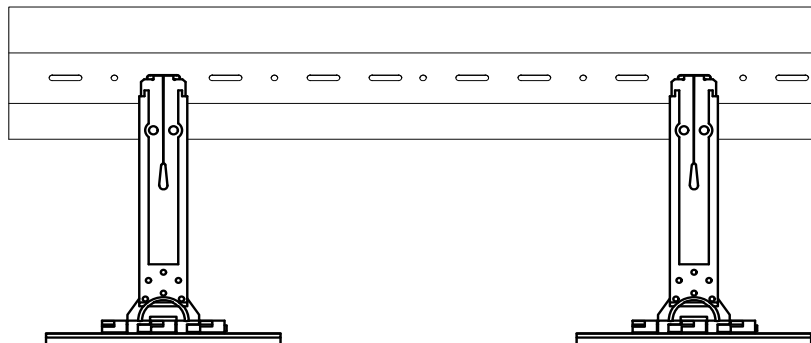

PERSPECTIVA:
(sem escala)

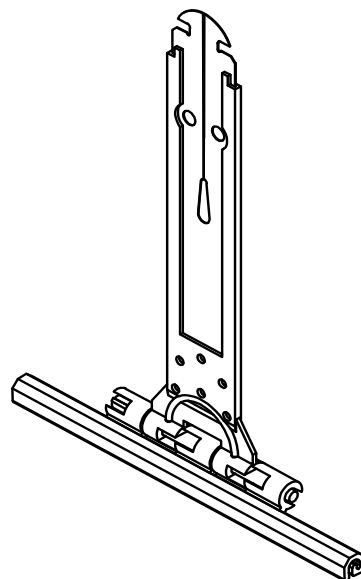

DIMENSÕES:
(escala 1:2)

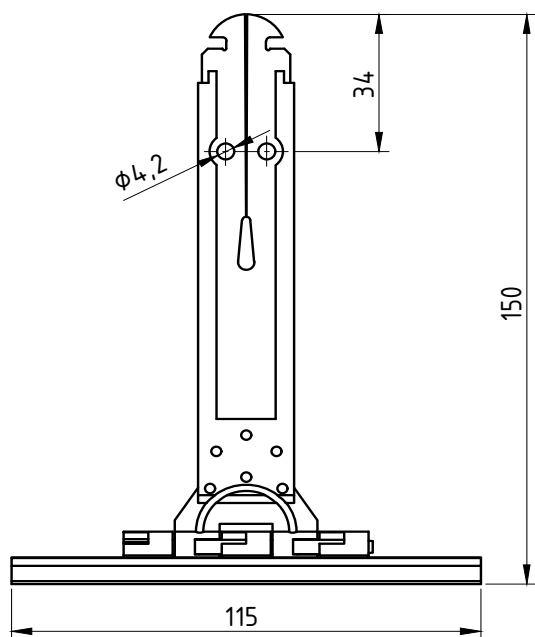

DETALHE DE APLICAÇÃO:
(sem escala)

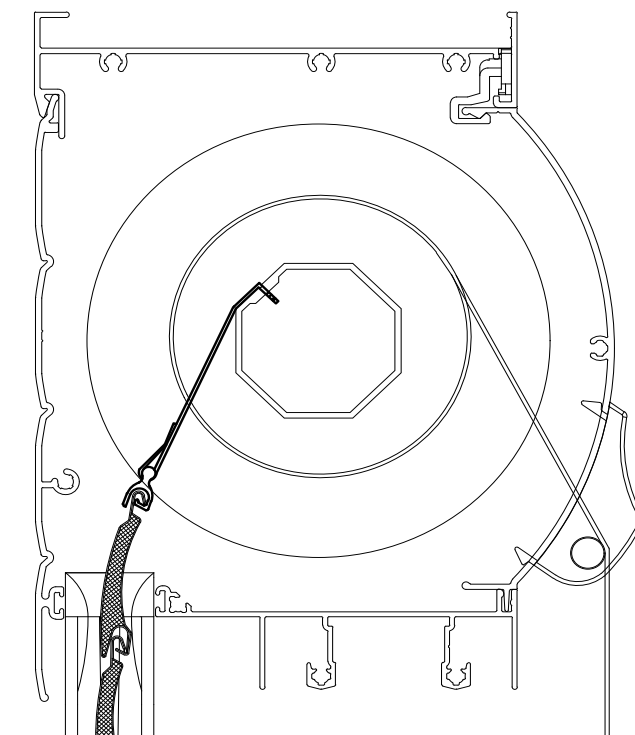

CARACTERÍSTICAS:

Componentes:	Matéria-prima:
Estrutura	Poliamida/Aço mola

Acabamento NATURAL

Embalagem 100 Peças

CÓDIGO	ACABAMENTO
FIT-148	NATURAL

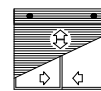
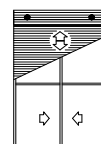

Portas e Janelas

PERSIANAS

DIMENSÕES:
(escala 1:2)

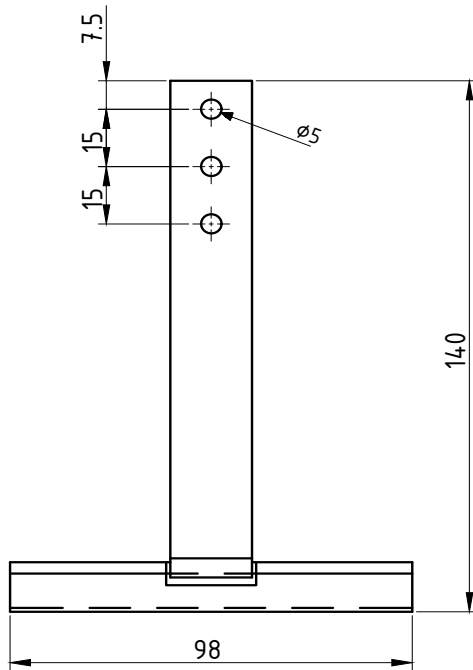

PERSPECTIVA:
(sem escala)

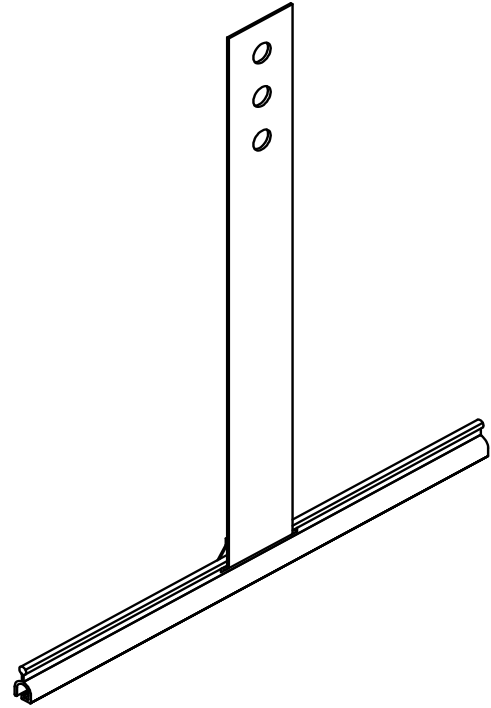

DETALHE DE APLICAÇÃO:
(sem escala)

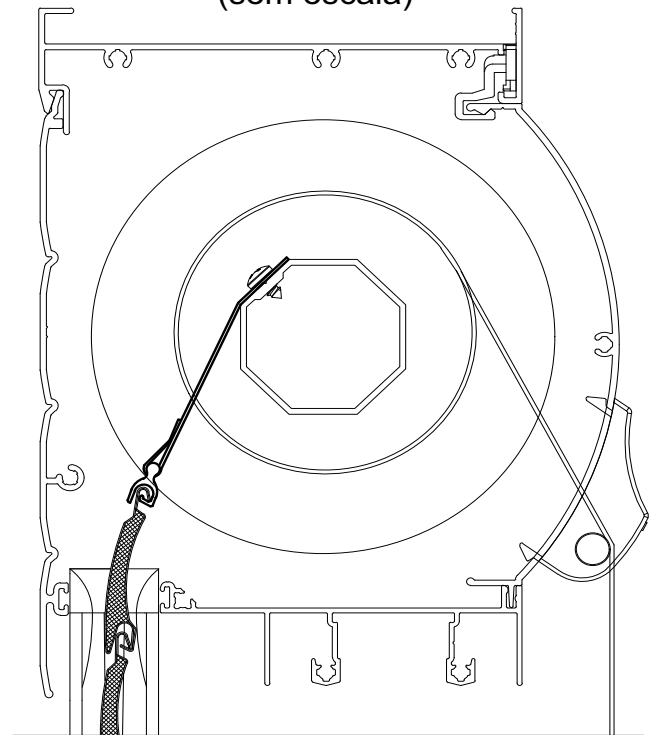

CARACTERÍSTICAS:

Componentes:	Matéria-prima:
Estrutura	Alumínio/Aço mola

Acabamento	Cinza
------------	-------

Embalagem	100 Peças
-----------	-----------

CÓDIGO	ACABAMENTO
FIT-749	Cinza

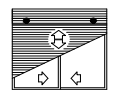
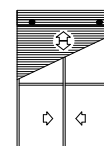

Portas e Janelas

PERSIANAS

DIMENSÕES:
(escala 1:2)

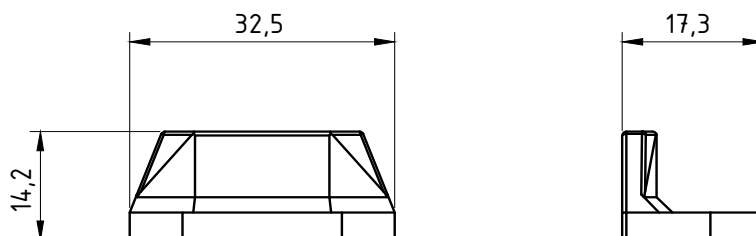

PERSPECTIVA:
(Sem escala)

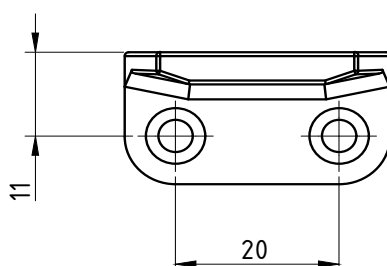
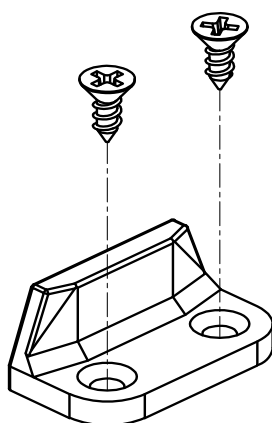

DETALHE DE APLICAÇÃO:
(sem escala)

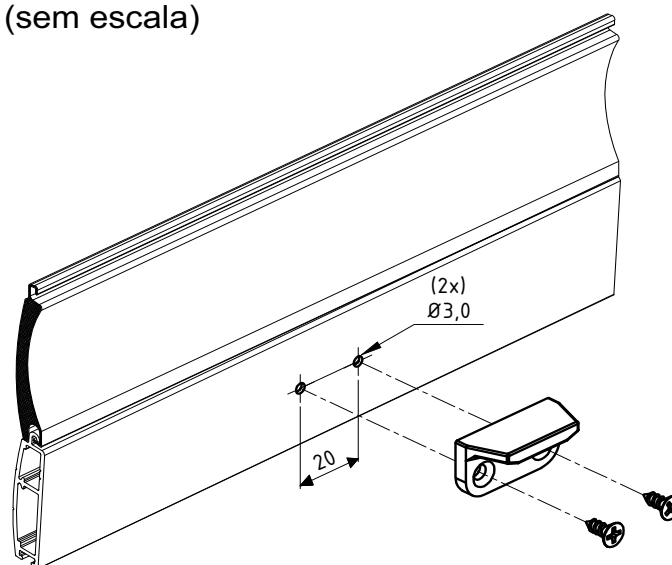

CARACTERÍSTICAS:

Componentes:	Matéria-prima:
Estrutura	Poliamida
Parafusos	Aço Inox

Acabamentos	
Preto	Branco

Embalagem	100 Limitadores
	200 Parafusos

CÓDIGO	ACABAMENTO
NYL-738	Preto
NYL-738NB	Branco

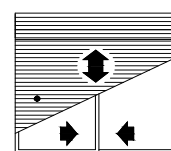

PERSIANA

Abril/2017

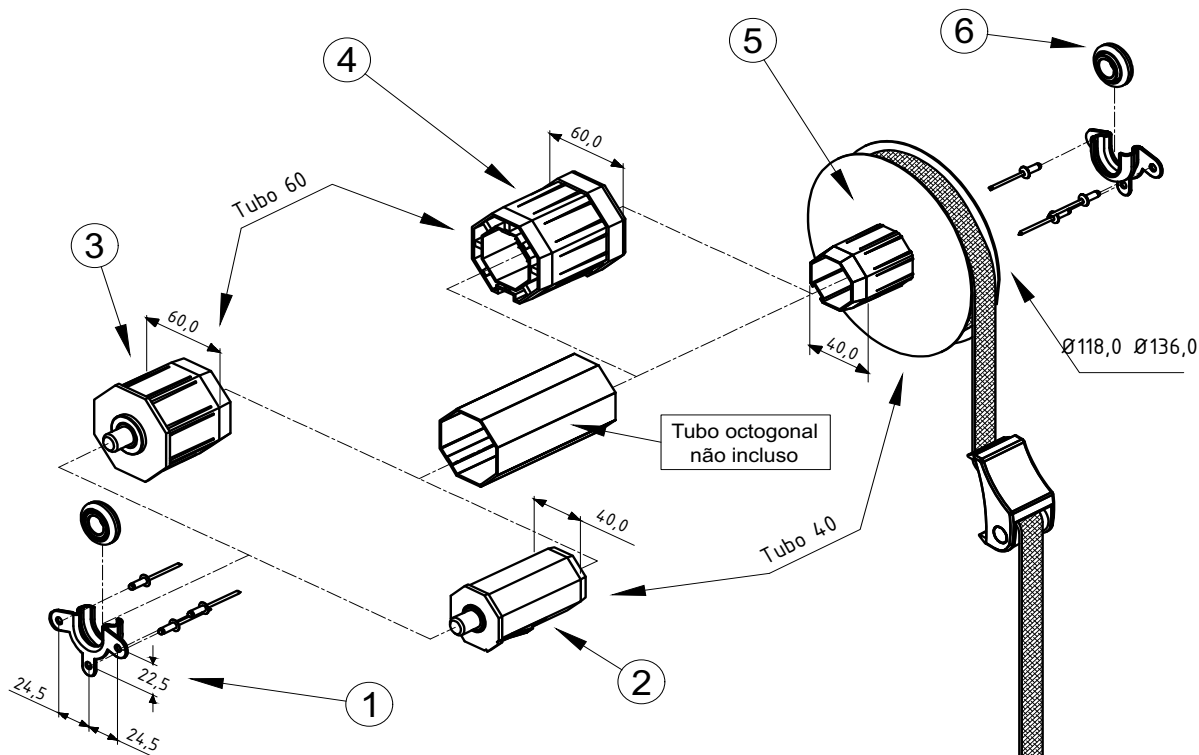

COMPRIMENTO DA CINTA 5,3M

CARACTERÍSTICAS:

N:	Componentes:	Matéria-prima:
1	Mancal do Recolhedor	Aço
2	Ponteira de Eixo 40mm	Aço / ABS
3	Ponteira de Eixo 60mm	Aço / ABS
4	Adaptador p/ Tubo 60mm	ABS
5	Polia Ø118,0	Aço / ABS
	Polia Ø136,0	Aço / ABS
6	Rolamento do Mancal	Aço / Poliamida
7	Guia da Cinta	Poliamida
8	Máquina externa	Poliamida
9	Parafuso	aço inox

Componentes p/ Fixação:	Matéria-prima:
Parafusos	Aço Inox
Rebites	Alumínio

Acabamentos:	
Preto	Branco

Embalagem	1 Conjunto
-----------	------------

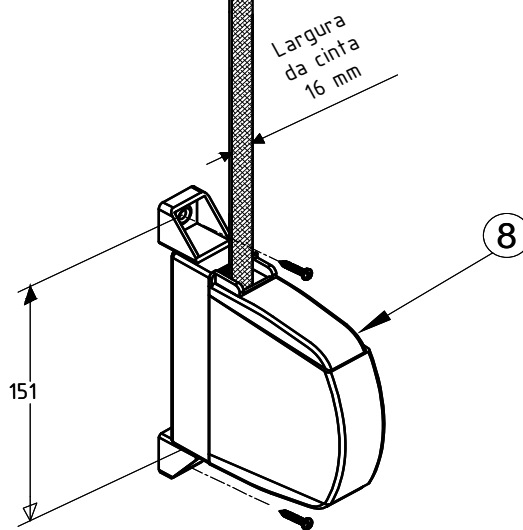

OBS: Detalhamento de montagem ver nas paginas 12.04 12.05

Código Preto	Código Branco	Tubo (mm)	Polia (mm)	Aplicação
REC - 124	REC - 124 EB	40	Ø118,0	Janela
REC - 125	REC - 125EB	40	Ø136,0	Porta
REC - 126	REC - 126 EB	60	Ø118,0	Janela
REC - 127	REC - 127 EB	60	Ø136,0	Porta

PERSIANA

Portas e Janelas

Peso Máximo: 12Kg
Altura máxima da Porta: 2,40 m

DIMENSÕES:
(escala 1:1)

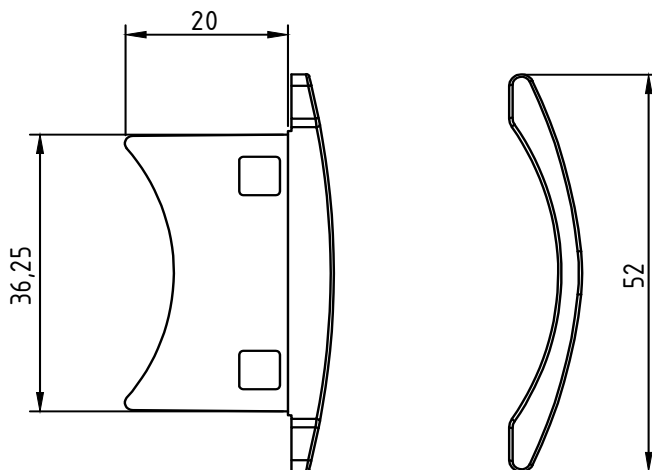

PERSPECTIVA:
(sem escala)

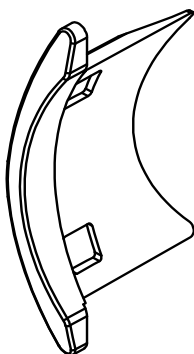

DETALHE DE APLICAÇÃO:
Sem Escala

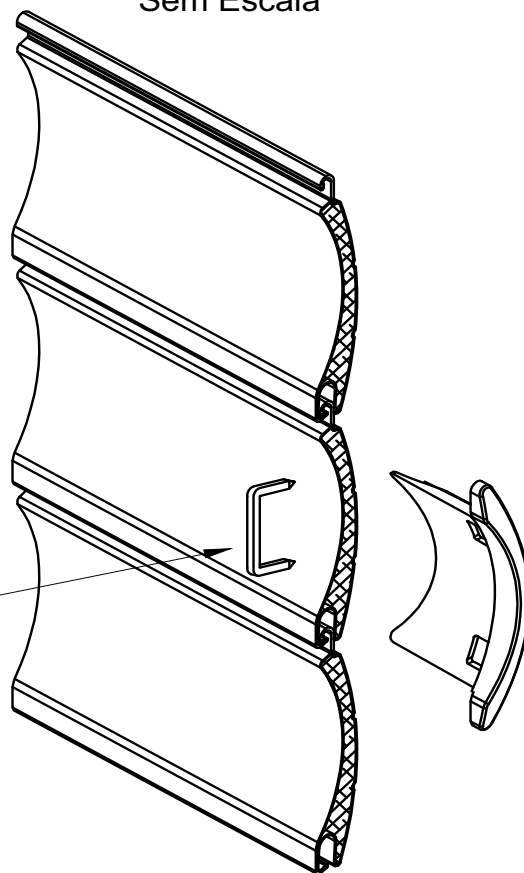

Grampo não fornecido

CARACTERÍSTICAS:

Componentes:	Matéria-prima:
Estrutura	Poliacetal
Embalagem	200 peças

CÓDIGO	ACABAMENTO
NYL 447	Preto

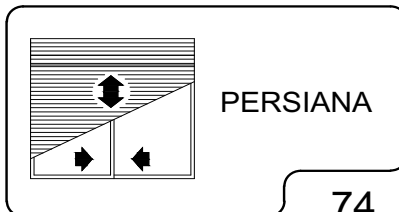

DIMENSÕES:
(escala 1:1)

DETALHES DE APLICAÇÃO:
(sem escala)

TERM-01
0,408kg/m

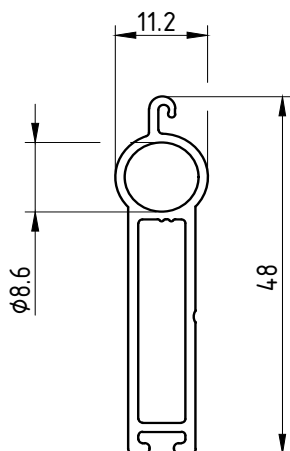

EXL-88055

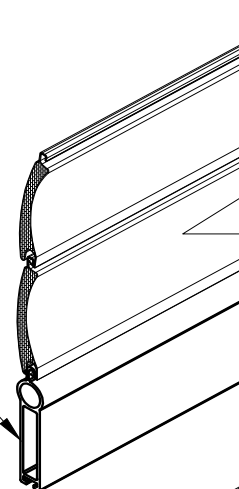

TERM-02
0,300kg/m

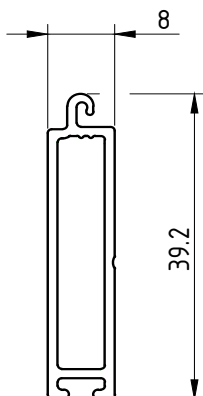

EXL-88999

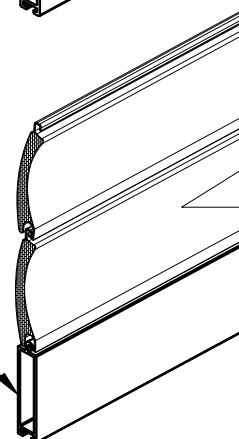

TERM-03
0,382kg/m

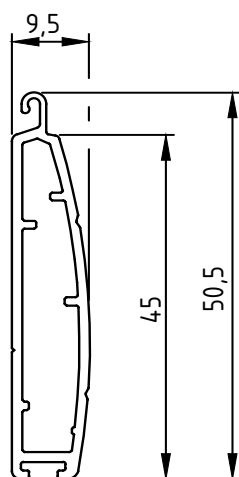

EXL-88340

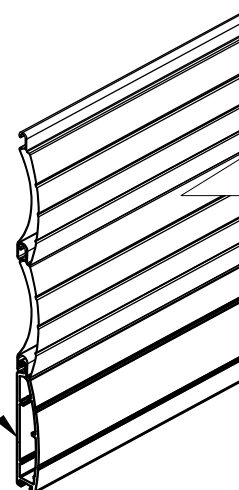

CARACTERÍSTICAS GERAIS:

Componentes:

Matéria-prima:

Estrutura

Alumínio

Embalagem

Barras de 6 metros
Pacotes de 10 peças

CÓDIGO	ACABAMENTO
TERM-01BZ	BRONZE ANOD.
TERM-01EB	BRANCO 9003
TERM-01FS	FOSCO ANOD.
TERM-01NT	NATURAL
TERM-01PT	PRETO ANOD.
TERM-02BZ	BRONZE ANOD.
TERM-02EB	BRANCO 9003
TERM-02FS	FOSCO ANOD.
TERM-02NT	NATURAL
TERM-02PT	PRETO ANOD.
TERM-03BZ	BRONZE ANOD.
TERM-03EB	BRANCO 9003
TERM-03FS	FOSCO ANOD.
TERM-03NT	NATURAL
TERM-03PT	PRETO ANOD.

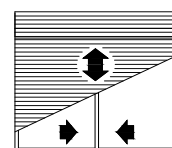

PERSIANAS



ALUMICONTE

COMPONENTES • PERFIS • PERSIANAS

**Completo, dinâmico
e repleto de soluções.**

Acesse:

www.dlumiconte.com.br

