

Abril/2006

PERSPECTIVA:
(sem escala)

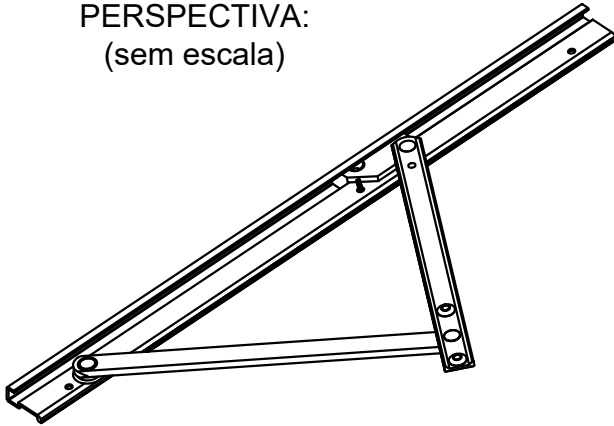

DIMENSÕES:
(escala 1:1)

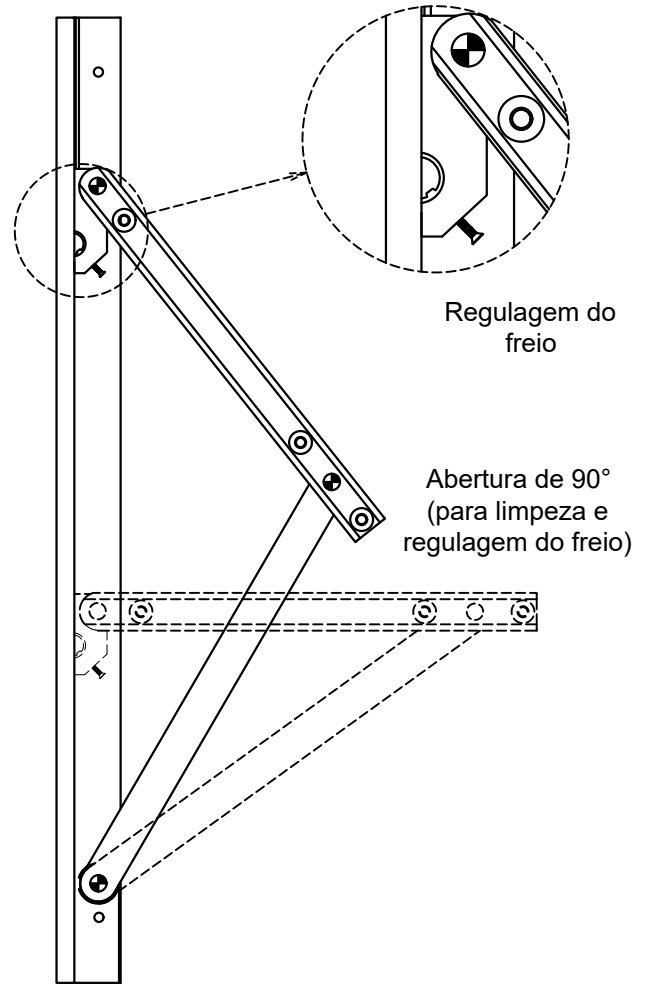
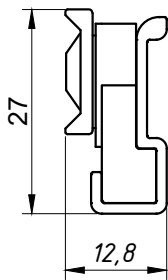

DETALHE DE APLICAÇÃO:
(escala 1:1)

CARACTERÍSTICAS:

Componentes:	Matéria-prima:
Estrutura	Alumínio
Rebites	Alumínio
Guia deslizante	Poliamida
Buchas	Poliamida

Acabamento

Preto Fosco Bronze 1003 Branco

Embalagem

1 par de braços
Rebites ou Parafusos

LADO INTERNO

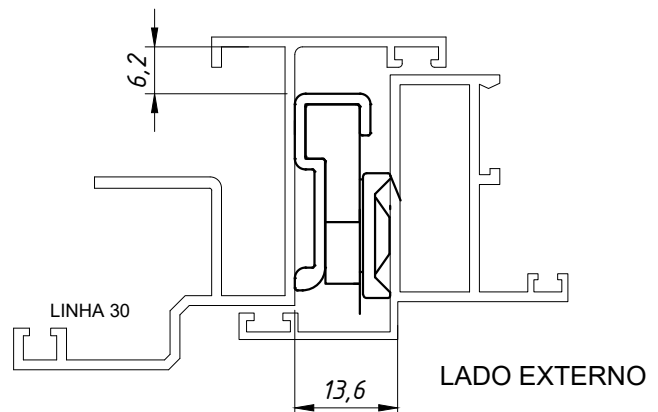

Código	Comp. (mm)	Altura (mm) Min./Máx.	Largura Máx. (mm)	Peso (Kg) Admissível	Vidro (mm) Esp. Máxima
BRA402C	270	275 a 350	800	8,0	6
BRA4002C	320	325 a 500	800	10,0	6
BRA405C	420	425 a 600	900	12,0	6
BRA408C	620	625 a 900	900	15,0	6
BRA411C	820	825 a 1000	1000	20,0	6
BRA442C	900	950 a 1200	1000	23,0	6

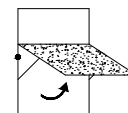

JANELAS
MAXIM-AR