

PERSPECTIVA:
(Escala 1:2)

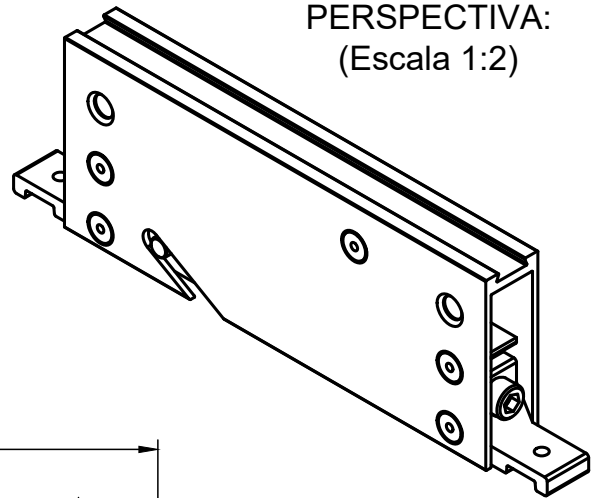

DIMENSÕES:
(Escala 1:2)

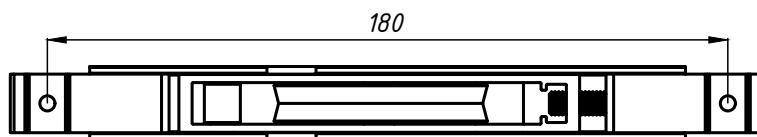
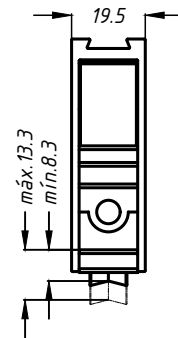
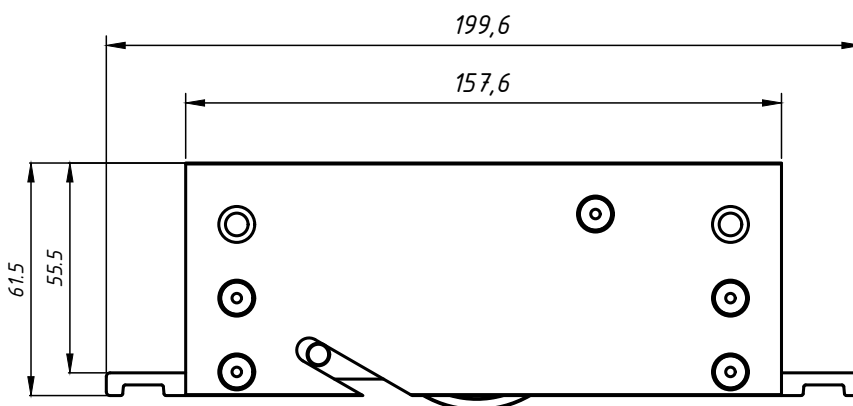

DETALHE DE APLICAÇÃO:
(sem escala)

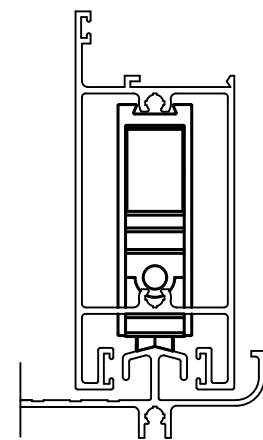

DETALHE DE USINAGEM
PG. 18.34

CARACTERÍSTICAS:

Componentes:	Matéria-prima:
Estrutura	Alumínio
Rolamento	Aço
Roda	Poliamida 30% FV
Eixos	Alumínio/aço inox
Parafusos	Aço inox

Embalagem	01 Roldana
-----------	------------

CÓDIGO	CARGA MAX.
ROL- 472	130 Kg/folha

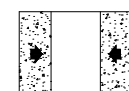

**PORTAS
DE CORRER**