

Abril/2006

PERSPECTIVA:
(sem escala)

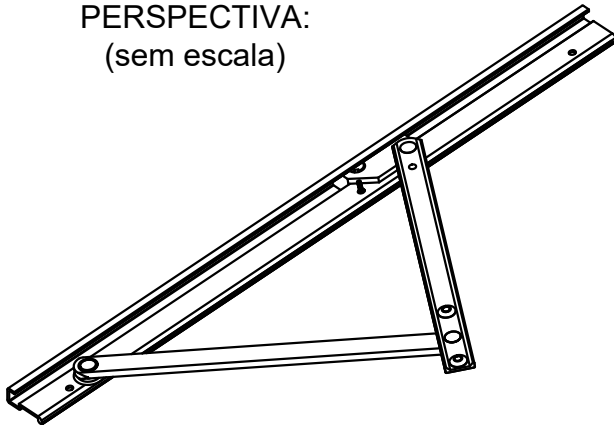

DIMENSÕES:
(escala 1:1)

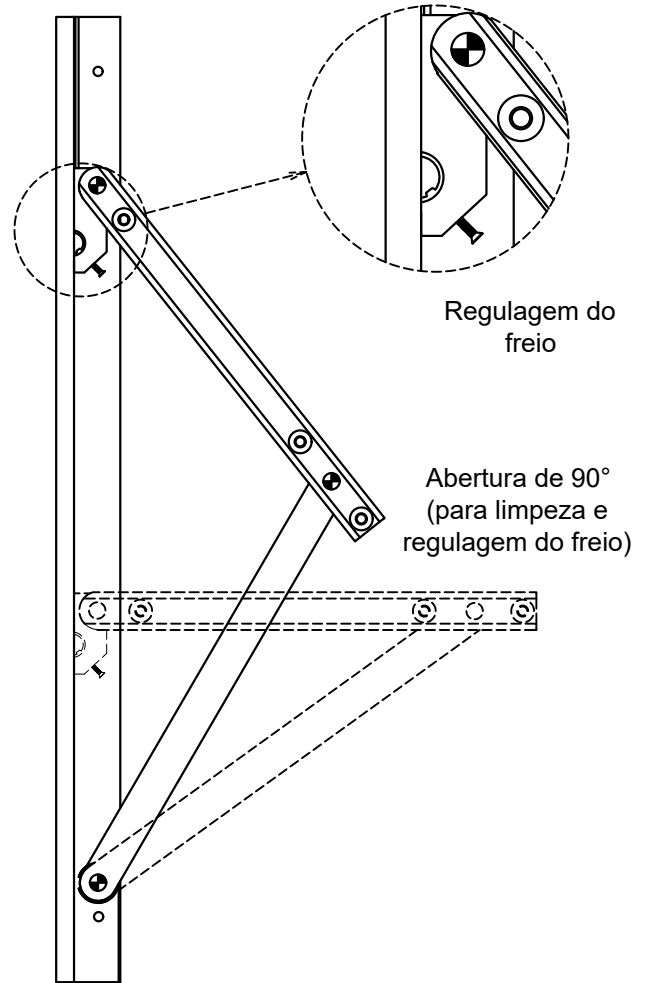
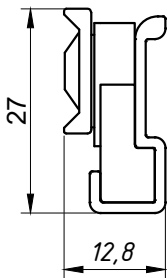

DETALHE DE APLICAÇÃO:
(escala 1:1)

CARACTERÍSTICAS:

Componentes:	Matéria-prima:
Estrutura	Alumínio
Rebites	Alumínio
Guia deslizante	Poliamida
Buchas	Poliamida

Acabamento

Preto Fosco Bronze 1003 Branco

Embalagem 1 par de braços
Rebites e Parafusos

LADO INTERNO

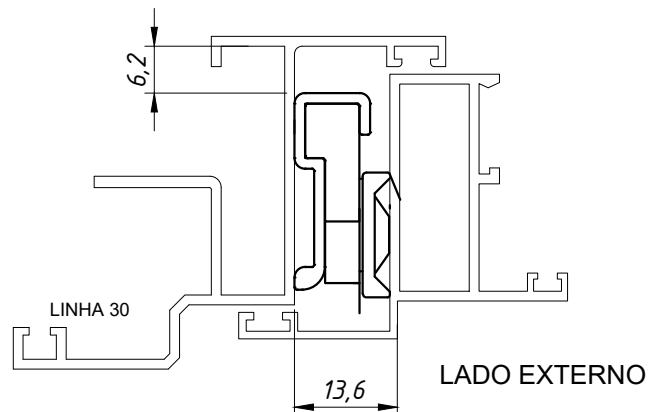

Código Preto	Código Fosco	Código Bronze	Código Branco	Comp. (mm)	Altura (mm) Mín./Máx.	Largura Máx. (mm)	Peso (Kg) Admissível	Vidro (mm) Esp. Máxima
BRA-402	BRA-400	BRA-401	BRA-402EB	270	275 a 350	800	8,0	6
BRA-4002	BRA-4000	BRA-4001	BRA-4002EB	320	325 a 500	800	10,0	6
BRA-405	BRA-403	BRA-404	BRA-405EB	420	425 a 600	900	12,0	6
BRA-408	BRA-406	BRA-407	BRA-408EB	620	625 a 900	900	15,0	6
BRA-411	BRA-409	BRA-410	BRA-411EB	820	825 a 1000	1000	20,0	6
BRA-442	BRA-441	BRA-443	BRA-442EB	900	950 a 1200	1000	23,0	6

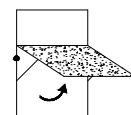

JANELAS
MAXIM-AR