



FECHO ALAVANCA
INJETADO
COM BAGUETE

APLICAÇÃO:
Linhas:
SUPREMA®, ABSOLUTA®,
HYDRO OFFICIAL®, ALUK 2.5®
IMPERIAL 2.5®, MEGA 25,
NOSTRA 25®

Setembro/2010 - REV.:01 Janeiro/2024

PERSPECTIVA:
(escala 1:1)

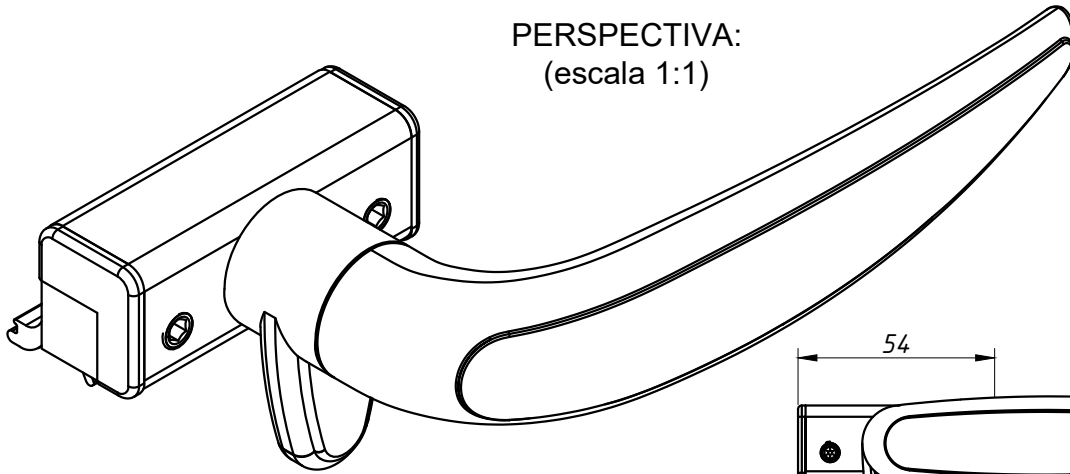

DIMENSÕES:
(escala 1:2)

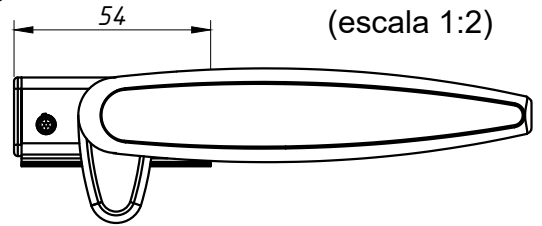

CONTRAFECHO:
(escala 1:1)

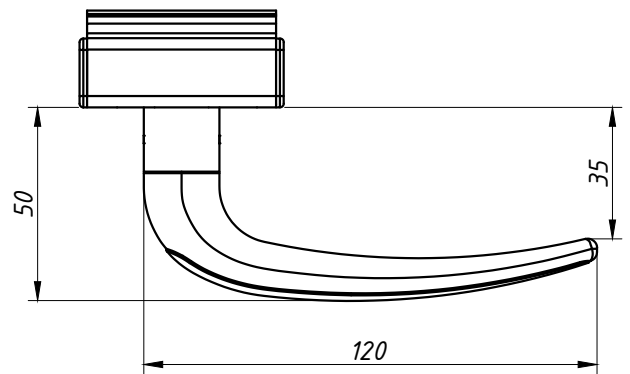
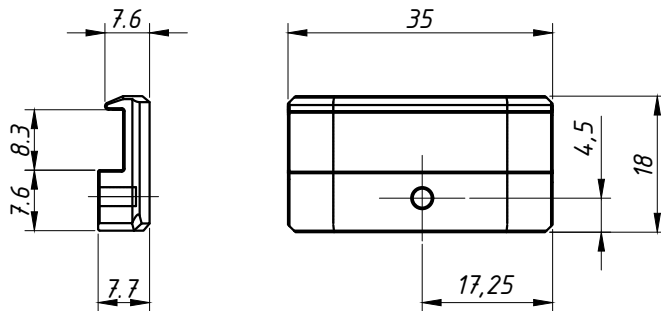

DETALHE DE APLICAÇÃO:
(escala 1:1)

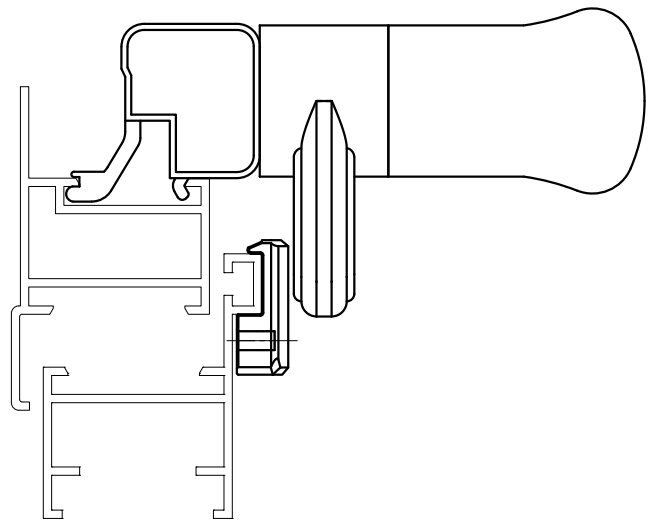

CARACTERÍSTICAS:

Componentes:	Matéria-prima:
Base	Alumínio
Alavanca	Zamac
Tampas	Poliamida
Trava	Zamac
Arruela	Aço Inox
Parafusos	Aço Inox

Acabamento	
Preto	Branco

Embalagem	10 Fechos
	20 Tampas
	20 Parafusos

CÓDIGO	ACABAMENTO
FEC-600D/P	Preto
FEC-600D/EB	Branco
FEC-600E/P	Preto
FEC-600E/EB	Branco

JANELAS
MAXIM-AR

8.12