

### DIMENSÕES: (escala 1:1)

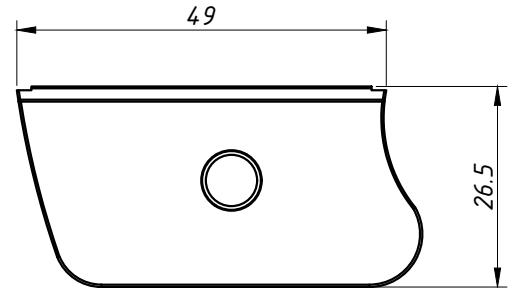

### PERSPECTIVA: (sem escala)

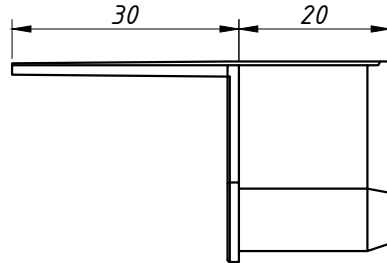
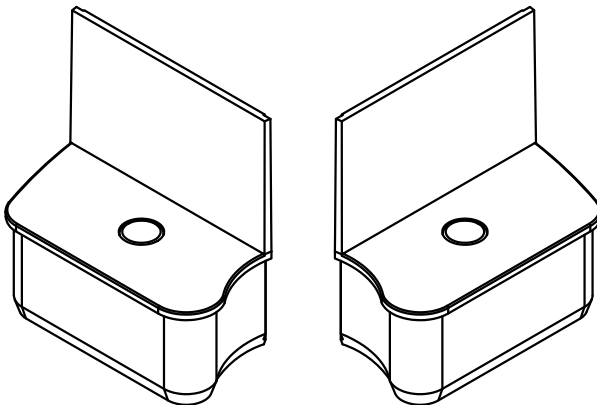

### DETALHE DE APLICAÇÃO: (sem escala)

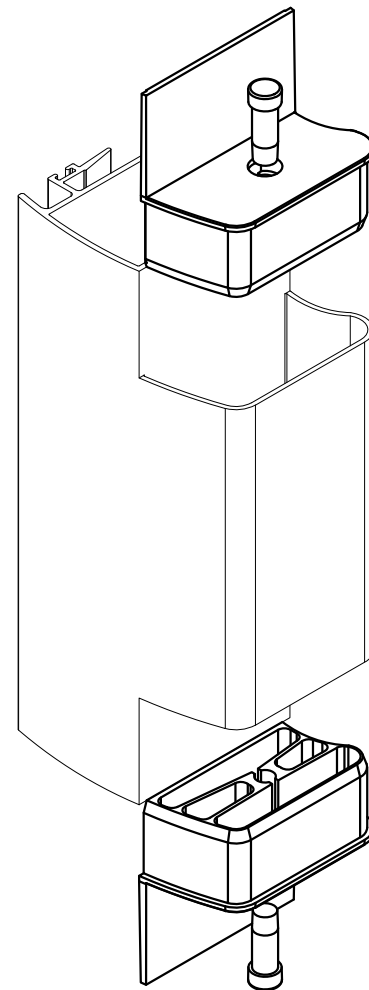

### CARACTERÍSTICAS:

Componentes:	Matéria-prima:
Estrutura	Poliamida
Pino	Poliamida

Acabamento	Preto Branco
------------	-----------------

Embalagem	10 Pares
-----------	----------

CÓDIGO	ACABAMENTO
TPA-320	Preto
TPA-320NB	Branco

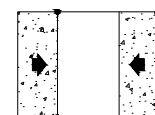

JANELAS  
E PORTAS  
DE CORRER